

XC9280 Series

18V Operation 3.0A Synchronous Step-Down DC/DC Converters

ETR05064-004

■ GENERAL DESCRIPTION

The XC9280 series is 18V bootstrap synchronous step-down DC/DC converter with built-in Nch-Nch driver transistors, the operating voltage range is 4.5V~18.0V, designed to allow the use of ceramic capacitors.

0.75V reference voltage source is incorporated in the IC, and the output voltage can be set to a value from 1.8V to 7.0V using external resistors (R_{FB1} , R_{FB2}).

Switching frequency is 1.2MHz. In PWM/PFM automatic switchover control, IC can change the control method between PWM and PFM based on the output current requirement and as a result IC can achieve high efficiency over the full load range.

XC9280 has a fixed internal soft start time which is 0.95ms (TYP.), additionally the time can be extended by using an external resistor and capacitor.

With the built-in UVLO function, the driver transistor is forced OFF when input voltage goes down to 3.33V (TYP.) or lower. Over current protection and thermal shutdown are embedded and they secure a safety operation.

■ APPLICATIONS

- Digital TV
- Set Top Box
- Security camera
- Smart meter
- Security system

■ FEATURES

Input Voltage Range	:	4.5V ~ 18V (Absolute Max 20V)
Output Voltage Range	:	1.8V ~ 7.0V or $V_{IN} \times 0.7$
FB Voltage	:	$0.75V \pm 1.5\%$
Oscillation Frequency	:	1.2MHz
Output Current	:	3A peak 2.0A DC ($V_{IN}=12V$, $V_{OUT}=5V$)
Control Method	:	PWM/PFM Automatic
Soft-start Time	:	0.95ms Adjustable by RC
Protection function	:	UVLO Over Current Protection (Automatic Recovery) Thermal Shutdown
Output Capacitor	:	Ceramic Capacitor
Package	:	TSOT-26
Environmentally Friendly	:	EU RoHS Compliant, Pb Free

■ TYPICAL APPLICATION CIRCUIT

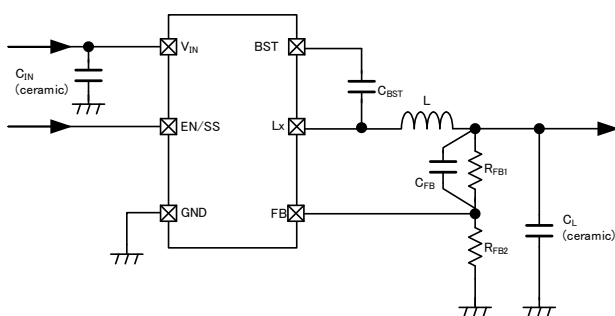

■ TYPICAL PERFORMANCE CHARACTERISTICS

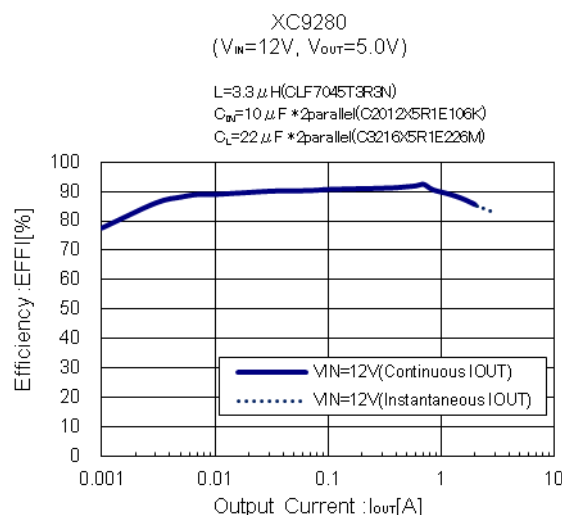

■ BLOCK DIAGRAM

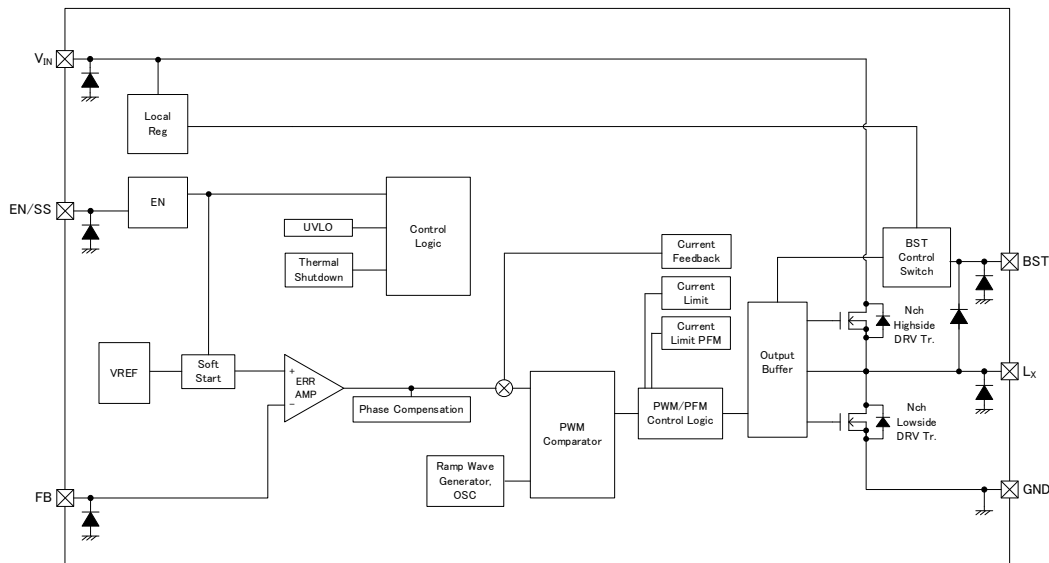

* Diodes inside the circuit are an ESD protection diodes and a parasitic diodes.

■ PRODUCT CLASSIFICATION

1) Ordering Information

XC9280①②③④⑤⑥-⑦^(*)

DESIGNATOR	ITEM	SYMBOL	DESCRIPTION
①	Type	A	Refer to Selection Guide
②③	FB Voltage	75	0.75V
④	Oscillation Frequency	C	1.2MHz
⑤⑥-⑦ ^(*)	Packages (Order Unit)	YR-G ^(*)	TSOT-26 (3,000pcs/Reel)

^(*) The "-G" suffix denotes Halogen and Antimony free as well as being fully EU RoHS compliant.

2) Selection Guide

TYPE	Chip Enable	UVLO	Thermal Shutdown
A	Yes	Yes	Yes

TYPE	Soft Start	Current Limiter	Automatic Recovery (Current Limiter)
A	Yes	Yes	Yes

■ PIN CONFIGURATION

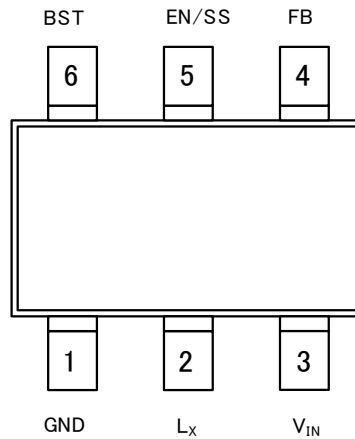

TSOT-26
(TOP VIEW)

■ PIN ASSIGNMENT

PIN NUMBER	PIN NAME	FUNCTIONS
TSOT-26		
1	GND	Ground
2	L _x	Switching Output
3	V _{IN}	Power Input
4	FB	Output Voltage Sense
5	EN/SS	Enable/Soft-start
6	BST	Bootstrap

■ FUNCTION CHART

PIN NAME	SIGNAL	STATUS
EN/SS	H	Active
	L	Stand-by
	OPEN	Undefined State ^(*)

^(*) Please do not leave the EN/SS pin open. Each should have a certain voltage.

■ ABSOLUTE MAXIMUM RATINGS

PARAMETER		SYMBOL	RATINGS	UNITS
V _{IN} Pin Voltage		V _{IN}	-0.3 ~ 20	V
EN/SS Pin Voltage		V _{EN/SS}	-0.3 ~ 20	V
FB Pin Voltage		V _{FB}	-0.3 ~ 6.2	V
BST Pin Voltage		V _{BST}	V _{LX} - 0.3 ~ V _{LX} + 6.2	V
Lx Pin Voltage		V _{LX}	-0.3 ~ V _{IN} + 0.3 or 20 ^(*)	V
Lx Pin Current		I _{LX}	6.0	A
Power Dissipation (Ta=25°C)	TSOT-26	Pd	1300 (High heat dissipation board) ^(**)	mW
Operating Ambient Temperature		Topr	-40 ~ 105	°C
Storage Temperature		Tstg	-55 ~ 125	°C

^(*) The maximum value should be either V_{IN}+0.3V or 20V in the lowest.

^(**) The power dissipation figure shown is PCB mounted and is for reference only.

Please refer to PACKAGING INFORMATION for the mounting condition.

■ ELECTRICAL CHARACTERISTICS

Ta=25°C

PARAMETER	SYMBOL	CONDITIONS	MIN.	TYP.	MAX.	UNIT	CIRCUIT
FB Voltage	V _{FB}	V _{FB} =0.761V → 0.739V V _{FB} Voltage when Lx pin oscillates	0.739	0.750	0.761	V	①
Setting Output Voltage Range ^(*)	V _{OUTSET}	-	1.8	-	7.0 or V _{IN} ×0.7 ^(*)	V	-
Operating Input Voltage Range ^(*)	V _{IN}	-	4.5	-	18	V	-
UVLO Detect Voltage	V _{UVLOD}	V _{IN} :4.4V→2.7V, V _{FB} =0.675V V _{IN} Voltage which Lx pin voltage changes from "oscillation" to "L" level	2.70	3.33	-	V	①
UVLO Release Voltage	V _{UVLOR}	V _{IN} :2.7V→4.4V, V _{FB} =0.675V V _{IN} Voltage which Lx pin voltage changes from "L" level to "oscillation"	-	3.38	4.40	V	①
Quiescent Current	I _q	V _{IN} =V _{EN/SS} =12V, V _{FB} =0.825V, V _{LX} =0V	-	80	180	μA	②
Stand-by Current	I _{STBY}	V _{IN} =12V, V _{EN/SS} =V _{FB} =V _{LX} =0V	-	3.0	6.0	μA	⑤
Oscillation Frequency	f _{OSC}	Connected to external components, V _{IN} =V _{EN/SS} =6.0V, V _{FB} =0.675V	1.0	1.2	1.4	MHz	①
Maximum Duty Cycle	D _{MAX}	Connected to external components, V _{IN} =V _{EN/SS} =6.0V, V _{FB} =0.675V	75	90	-	%	①
Lx SW "H" On Resistance	R _{LxH}	-	-	166 ^(*)	-	mΩ	-
Lx SW "L" On Resistance	R _{LxL}	V _{FB} =5.5V, I _{LX} =100mA	-	130	-	mΩ	③
Lx SW "H" Off Current	I _{LxH}	V _{IN} =18V, V _{EN/SS} =0V, V _{FB} =1.5V V _{LX} =6.0V, V _{BST} =V _{LX} +5.0V	-1.0	-	-	μA	⑥
Lx SW "L" Off Current	I _{LxL}	V _{IN} =18V, V _{EN/SS} =V _{FB} =V _{LX} =0V	-	-	1.0	μA	⑧
PFM Switch Current	I _{PFM}	Connected to external components, V _{IN} =12V, V _{OUT} =5.0V, I _{OUT} =1mA	-	1.2	-	A	④
Current Limit	I _{LIM}	-	-	5.1	-	A	-
Internal Soft-Start Time	t _{SS1}	V _{FB} =0.675V	-	0.95	-	ms	①
External Soft-Start Time	t _{SS2}	V _{FB} =0.675V R _{SS} =430kΩ, C _{SS} =0.47 μF	-	26	-	ms	⑦
Efficiency ^(*)	EFFI	Connected to external components, V _{IN} =12V, V _{OUT} =5.0V, I _{OUT} =1.0A	-	90	-	%	④
FB Voltage Temperature Characteristics	$\frac{\Delta V_{FB}}{(\Delta T_{opr} \cdot V_{FB})}$	-40°C ≤ T _{opr} ≤ 105°C	-	±100	-	ppm/°C	①

Test Condition: Unless otherwise stated, V_{IN}=12V, V_{EN/SS}=12V

(*)1: Please use within the range of V_{OUT}/V_{IN} ≥ 0.136

(*)2: Design reference value. This parameter is provided only for reference.

(*)3: EFFI = {(output voltage) x (output current)} / {(input voltage) x (input current)} x 100

(*)4: The maximum value should be either 7.0 or V_{IN}×0.7 in the lowest.

ELECTRICAL CHARACTERISTICS

Ta=25°C

PARAMETER	SYMBOL	CONDITIONS	MIN.	TYP.	MAX.	UNIT	CIRCUIT
FB "H" Current	I _{FBH}	V _{IN} =V _{EN/SS} =18V, V _{FB} =3.0V, V _{LX} =0V	-0.1	-	0.1	μA	⑧
FB "L" Current	I _{FBL}	V _{IN} =V _{EN/SS} =18V, V _{FB} =V _{LX} =0V	-0.1	-	0.1	μA	⑧
EN/SS "H" Voltage	V _{EN/SSH}	V _{IN} =18V, V _{FB} =0.71V	2.5	-	18	V	①
EN/SS "L" Voltage	V _{EN/SSL}	V _{IN} =18V, V _{FB} =1.5V	-	-	0.3	V	①
EN/SS "H" Current	I _{EN/SSH}	V _{IN} =V _{EN/SS} =18V, V _{FB} =1.5V, V _{LX} =0V	-	0.1	0.3	μA	⑧
EN/SS "L" Current	I _{EN/SSL}	V _{IN} =18V, V _{EN/SS} =V _{FB} =V _{LX} =0V	-0.1	-	0.1	μA	⑧
Thermal Shutdown Temperature	T _{TSD}	Junction Temperature	-	150	-	°C	-
Hysteresis Width	T _{HYS}	Junction Temperature	-	10	-	°C	-

Test Condition: Unless otherwise stated, V_{IN}=12V, V_{EN/SS}=12V

■ TEST CIRCUITS

CIRCUIT①

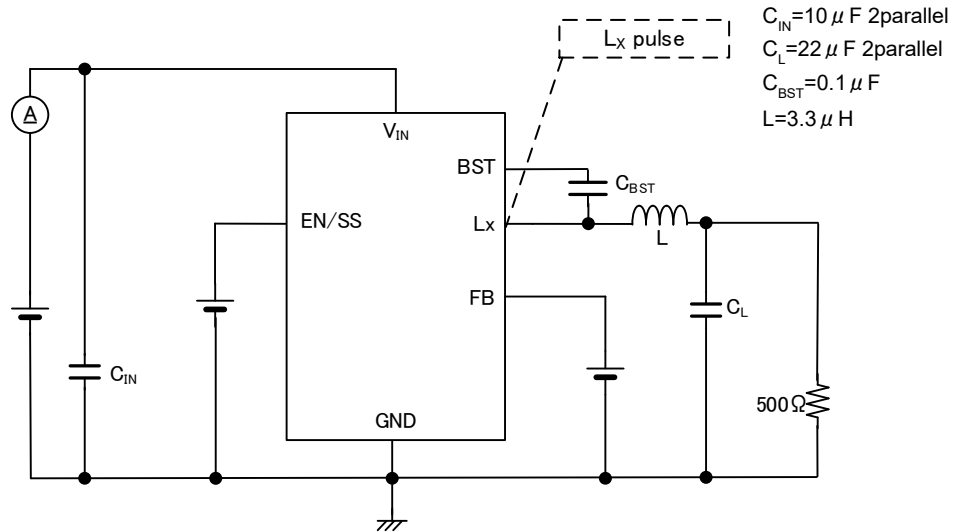

CIRCUIT②

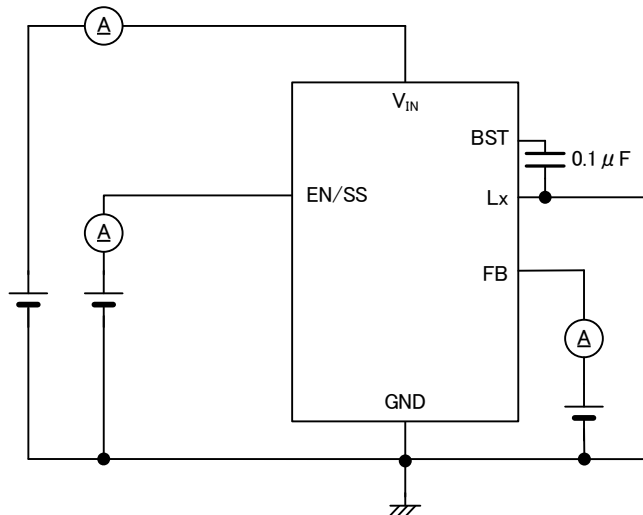

CIRCUIT③

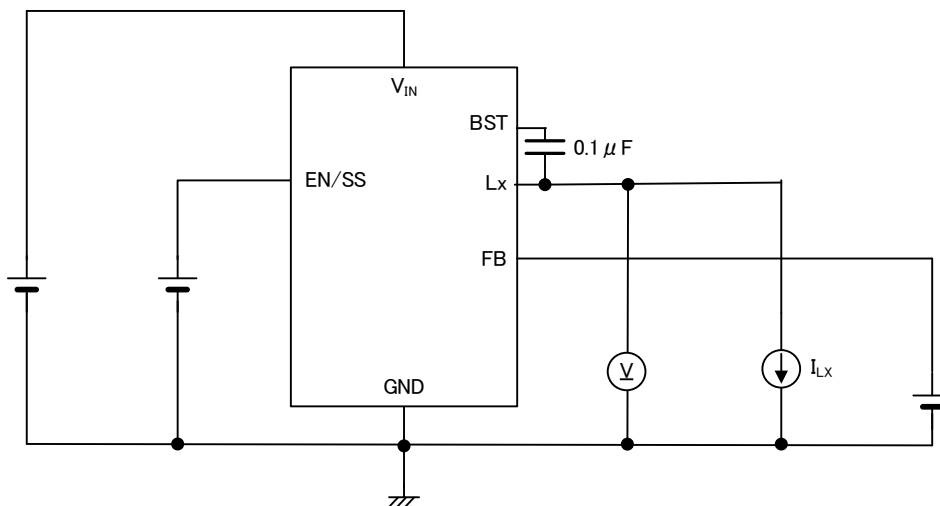

TEST CIRCUITS(Continued)

CIRCUIT④

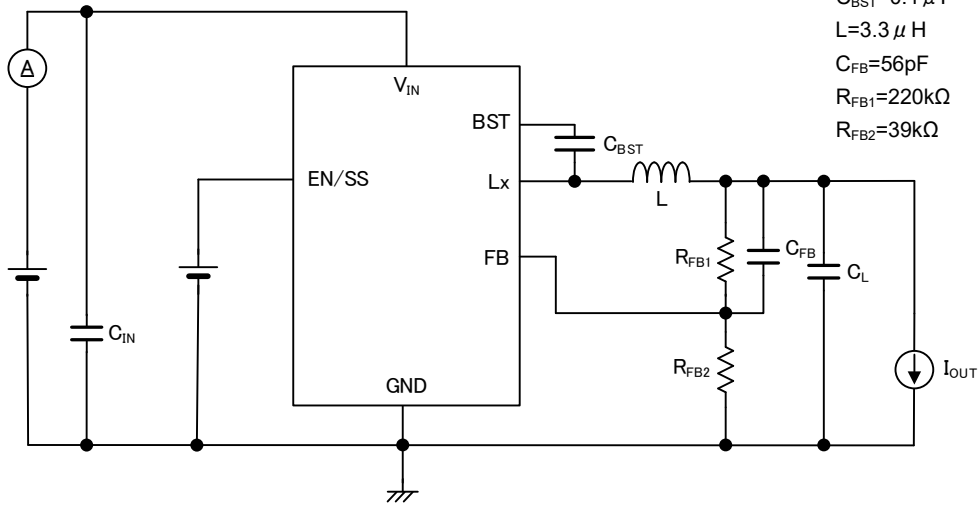

CIRCUIT⑤

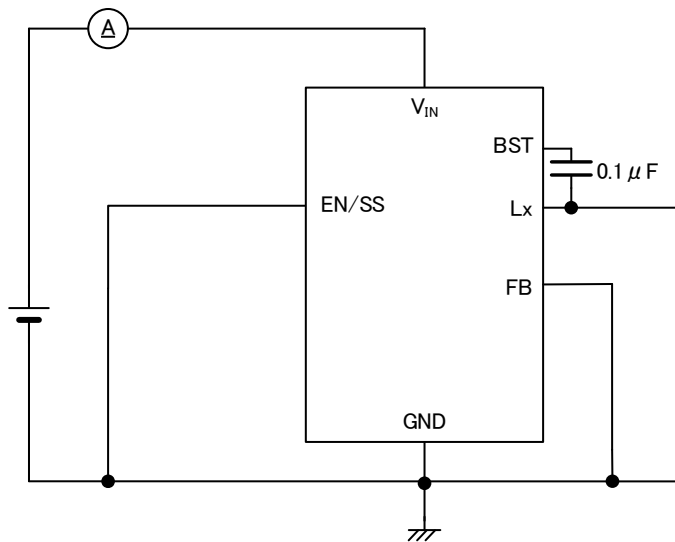

CIRCUIT⑥

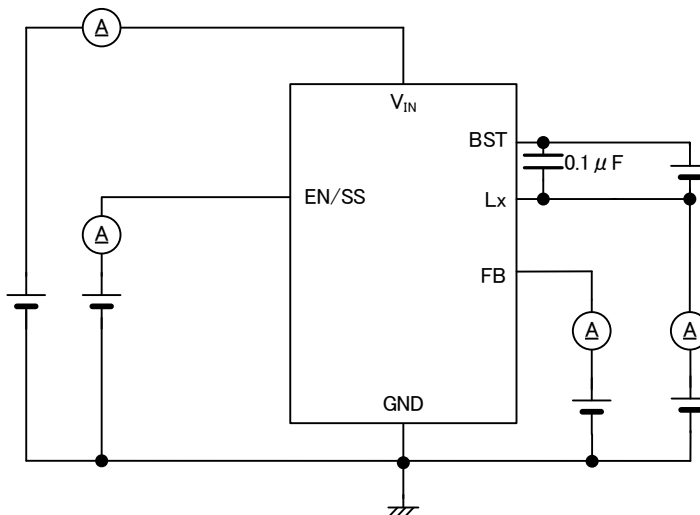

■ TEST CIRCUITS(Continued)

CIRCUIT⑦

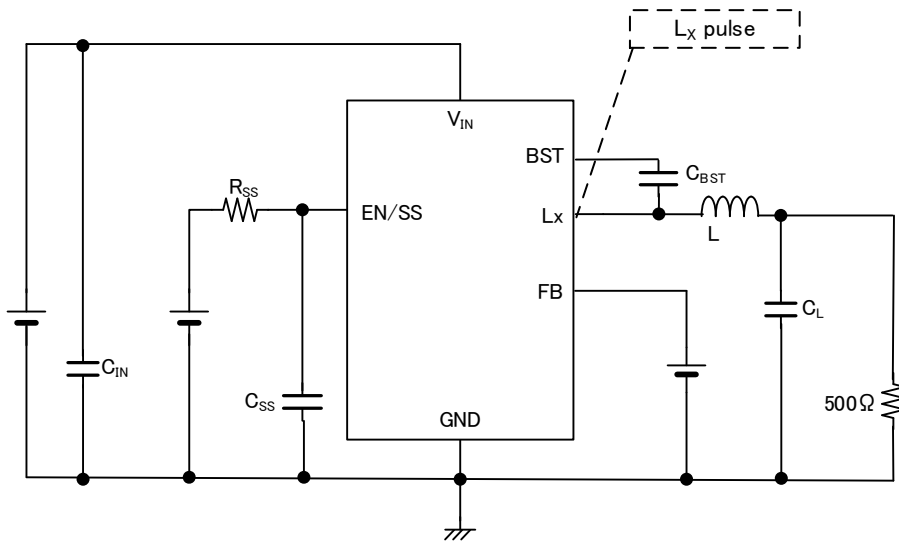

$C_{IN}=10\ \mu\text{F}$ 2parallel
 $C_L=22\ \mu\text{F}$ 2parallel
 $C_{BST}=0.1\ \mu\text{F}$
 $L=3.3\ \mu\text{H}$
 $R_{SS}=430\text{k}\Omega$
 $C_{SS}=0.47\ \mu\text{F}$

CIRCUIT⑧

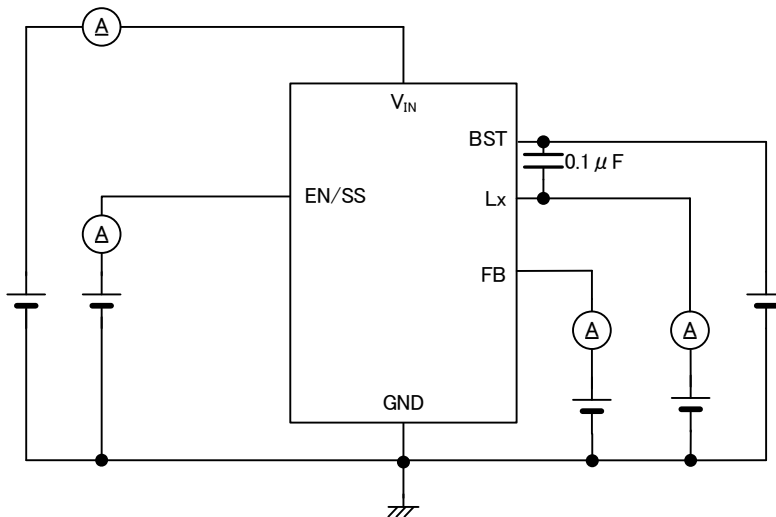

TYPICAL APPLICATION CIRCUIT

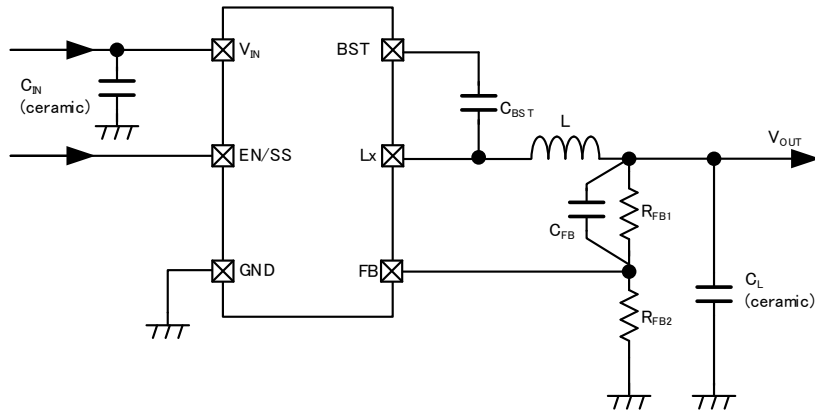

	V _{OUT}	MANUFACTURER	PRODUCT NUMBER	VALUE			
L	5.0V ~ 7.0V	TDK	VLS5045EX-3R3N	3.3μH			
			CLF7045NIT-3R3N				
	1.8V ~ 4.9V	TDK	VLS5045EX-2R2N				
			CLF7045NIT-2R2N				
C _{IN}	-	TDK	C2012X5R1E106K	10μF/25V 2Parallel			
			C3216X7R1E106K	10μF/25V 2Parallel			
			C _L	3.3V ~ 7.0V	TDK	C3216X5R1E226M	22μF/25V 2Parallel
						C4532X7R1E226M	22μF/25V 2Parallel
1.8V ~ 3.2V	TDK	C3216X5R1E226M	22μF/25V 3Parallel				
		C4532X7R1E226M	22μF/25V 3Parallel				
C _{BST}	-	-	-	0.1μF/25V			

<Output voltage setting>

The output voltage can be set by adding an external dividing resistor.
The output voltage is determined by the equation below based on the values of R_{FB1} and R_{FB2}.

$$V_{OUT} = 0.75 \times (R_{FB1} + R_{FB2}) / R_{FB2}$$

With $R_{FB2} \leq 50k\Omega$

<CFB setting>

Adjust the value of the phase compensation speed-up capacitor C_{FB} using the equation below.

$$C_{FB} = \frac{1}{2\pi \times f_{zfb} \times R_{FB1}}$$

When V_{OUT}=3.3V~7.0V, a target value for f_{zfb} of about 10k~15kHz is optimum.
When V_{OUT}=1.8V~3.2V, a target value for f_{zfb} of about 30k~35kHz is optimum.

【Setting Example】

V_{OUT} setting= 5.0V, R_{FB1}=220kΩ, R_{FB2}=39kΩ
 $V_{OUT} = 0.75V \times (220k\Omega + 39k\Omega) / 39k\Omega = 5.0V$
 f_{zfb}=12.9kHz
 $C_{FB} = 1 / (2 \times \pi \times 12.9kHz \times 220k\Omega) = 56pF$

【examples】

V _{OUT}	R _{FB1}	R _{FB2}	C _{FB}
5.0V	220kΩ	39kΩ	56pF
3.3V	91kΩ	27kΩ	120pF
1.8V	51kΩ	36kΩ	100pF

■ TYPICAL APPLICATION CIRCUIT (Continued)

<Soft-start Time Setting>

The soft-start time can be adjusted by adding a capacitor and a resistor to the EN/SS pin.
Soft-start time (t_{ss2}) is approximated by the equation below according to values of $V_{EN/SS}$, R_{SS} , and C_{SS} .

$$t_{ss2} = C_{SS} \times R_{SS} \times (\ln(V_{EN/SS} / (V_{EN/SS} - 1.45)))$$

【Setting Example】

$C_{SS} = 0.47 \mu\text{F}$, $R_{SS} = 430 \text{k}\Omega$, $V_{EN/SS} = 12\text{V}$
 $t_{ss2} = 0.47 \times 10^{-6} \times 430 \times 10^3 \times (\ln(12 / (12 - 1.45))) = 26\text{ms}$

* The soft-start time is the time from the start of $V_{EN/SS}$ until the output voltage reaches 90% of the set voltage.
 If the EN/SS pin voltage rises without connecting C_{SS} and R_{SS} ($R_{SS} = 0\Omega$), Output rises with taking the soft-start time of $t_{ss1} = 0.95\text{ms}$ (TYP.) which is fixed internally.

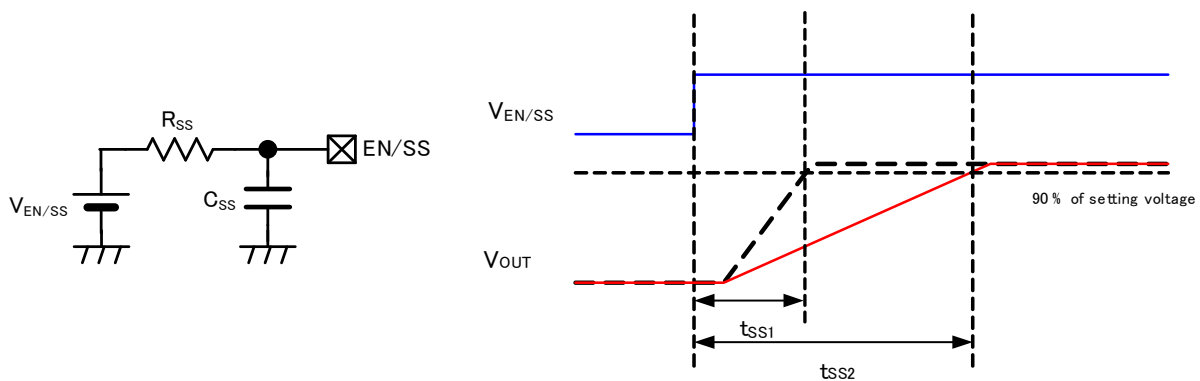

OPERATIONAL EXPLANATION

The XC9280 series consists of a reference voltage source circuit, soft-start circuit, error amplifier circuit, PWM comparator circuit, PWM/PFM control circuit, ramp wave circuit, oscillator (OSC) circuit, phase compensation (Current feedback) circuit, current limit circuit, current limit PFM circuit, Nch High-side driver Tr., Nch Low-side driver Tr., output buffer circuit, internal power supply (LocalReg) circuit, under-voltage lockout (UVLO) circuit, BST control circuit, thermal shutdown (TSD) circuit, control logic circuit.

The voltage feedback from the FB pin is compared to the internal reference voltage by the error amp, the output from the error amp is phase compensated, and the signal is input to the PWM comparator to determine the ON time of switching during PWM operation. The output signal from the error amp is compared to the ramp wave by the PWM comparator, and the output is sent to the buffer drive circuit and output from the LX pin as the duty width of switching. This operation is performed continuously to stabilize the output voltage.

The driver transistor current is monitored at each switching by the phase compensation (Current feedback) circuit, and the output signal from the error amp is modulated as a multi-feedback signal. This allows a stable feedback system to be obtained even when a low ESR capacitor such as a ceramic capacitor is used, and this stabilizes the output voltage.

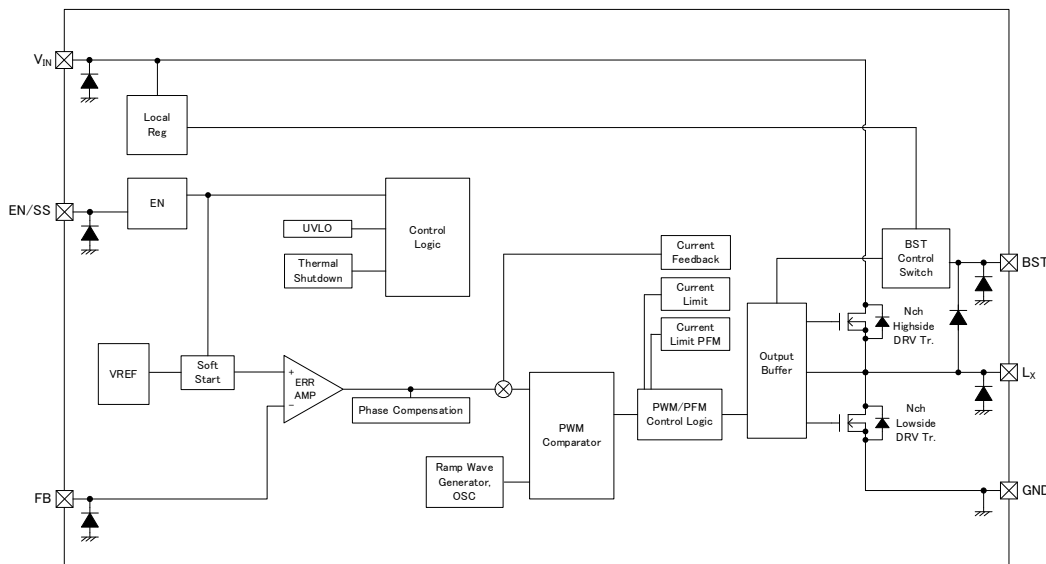

* Diodes inside the circuits are ESD protection diodes and parasitic diodes.

<Reference voltage source>

The reference voltage source provides the reference voltage to ensure stable output voltage of the DC/DC converter.

<Oscillator circuit>

The ramp wave circuit determines switching frequency (1.2MHz).

Clock pulses generated in this circuit are used to produce ramp waveforms needed for PWM operation.

<Error amplifier>

The error amplifier is designed to monitor output voltage. The amplifier compares the reference voltage with the feedback voltage divided by the internal voltage divider, R_{FB1} and R_{FB2} . When a voltage is lower than the reference voltage, then the voltage is fed back, the output voltage of the error amplifier increases. The error amplifier output is fixed internally to deliver an optimized signal to the mixer.

■ OPERATIONAL EXPLANATION (Continued)

< Current limiting, Short-circuit protection >

The XC9280 series incorporates a foldback circuit for current limiting and short-circuit protection.

When the output current reaches the current limit, the output voltage falls and the output current is limited.

When the overcurrent condition is canceled, the output voltage automatically recovers.

<Soft-start function>

The output voltage is soft-started by soft-starting the reference voltage.

The rise time of this reference voltage is the soft start time.

The soft-start time is set to 0.95ms (TYP.) which is fixed internally or to the time set by adding a capacitor and a resistor to the EN/SS pin whichever is later.

<Thermal shutdown>

The thermal shutdown (TSD) as an over temperature limit is built in the XC9280 series.

When the junction temperature reaches the detection temperature, the driver transistor is forcibly turned off. When the junction temperature falls to the release temperature while in the output stop state, restart takes place by soft-start 0.95ms (TYP.).

<UVLO>

This is a function to monitor the internal power supply and to prevent the output of false pulses from the Lx pin when the output from the internal power supply is unstable at low voltages.

As the V_{IN} pin voltage goes down, the internal power supply voltage falls. So the V_{IN} voltage drops, the UVLO function is activated.

When the V_{IN} pin voltage falls below V_{UVLOD} (TYP. 3.33V), the driver transistor is forcibly turned off to prevent false pulse output due to instable operation of the internal circuits. When the V_{IN} pin voltage rises above V_{UVLOR} (TYP. 3.38V), the UVLO function is released, the soft-start function activates, and output start operation begins. Stopping by UVLO is not shutdown; only pulse output is stopped and the internal circuits continue to operate.

When the V_{IN} pin voltage falls below V_{UVLOD} (TYP. 3.33V), the UVLO function is activated.

NOTE ON USE

- 1) For the phenomenon of temporal and transitional voltage decrease or voltage increase, the IC may be damaged or deteriorated if IC is used beyond the absolute MAX. specifications.
- 2) Spike noise and ripple voltage arise in a switching regulator as with a DC/DC converter. These are greatly influenced by external component selection, such as the coil inductance, capacitance values, and board layout of external components. Once the design has been completed, verification with actual components should be done.
- 3) Make sure that the absolute maximum ratings of the external components and of this IC are not exceeded.
- 4) The DC/DC converter characteristics depend greatly on the externally connected components as well as on the characteristics of this IC, so refer to the specifications and standard circuit examples of each component when carefully considering which components to select. Be especially careful of the capacitor characteristics and use B characteristics (JIS standard) or X7R, X5R (EIA standard) ceramic capacitors. The capacitance decrease caused by the bias voltage may become remarkable depending on the external size of the capacitor.
- 5) The ripple voltage could be increased when switching from discontinuous conduction mode to Continuous conduction mode. Especially when the input / output potential difference voltage is low, the ripple voltage may increase. Please evaluate IC well on customer's PCB.
- 6) If the voltage at the EN/SS Pin does not start from 0V but it is at the midpoint potential when the power is switched on, the soft-start function may not work properly and it may cause the larger inrush current.
- 7) The actual coil current may exceed the current limit value due to internal propagation delay.
- 8) When the voltage difference between input voltage and output voltage is low, the load regulation may be deteriorated by being limited by MAXDUTY.
- 9) In order to drive the IC normally, supply a stable input voltage to the V_{IN} pin after reducing the AC impedance due to the bypass capacitor. In particular, if the amplitude of the input voltage fluctuates by 7V or more and $\pm 0.4V/\mu s$ or more, there is a possibility that the UVLO function malfunctions due to fluctuations of the internal power supply of the IC. In that case, switching is stopped in a protected state that prevents false pulse output from the Lx pin. After that, the soft start function gets started, it shifts to normal operation. If the input voltage fluctuates momentarily, take measures such as increasing the input capacitance.
- 10) Torex places an importance on improving our products and their reliability. We request that users incorporate fail-safe designs and post-aging protection treatment when using Torex products in their systems.

NOTE ON USE (Continued)

10) Instructions of pattern layouts The operation may become unstable due to noise and/or phase lag from the output current when the wire impedance is high, please place the input capacitor(C_{IN}) and the output capacitor (C_L) as close to the IC as possible.

- (1) In order to stabilize V_{IN} voltage level, we recommend that a by-pass capacitor (C_{IN}) be connected as close as possible to the V_{IN} and GND pins.
- (2) Please mount each external component as close to the IC as possible.
- (3) Wire external components as close to the IC as possible and use thick, short connecting traces to reduce the circuit impedance.
- (4) Make sure that the GND traces are as thick as possible, as variations in ground potential caused by high ground currents at the time of switching may result in instability of the IC.
- (5) Please note that internal driver Tr. bring on heat because of the load current and ON resistance of High-side driver Tr., Low-side driver Tr..
- (6) Please note that T_j should be lower than 125°C.
 If it exceeds the value calculated from the following calculation formula, the thermal shutdown will operate due to the heat generation of the IC due to safety.
 Reference Pattern Layout θ_{JA}= 64[°C/W]
 Calculated values may not match actual operation depending on usage environment, usage conditions, transient conditions, etc.
 Please evaluate IC well on customer's PCB.

<DC Maximum Output Voltage vs. Operating Ambient Temperature>

$P_{loss} = V_{OUT} \times I_{OUT} \times (1/EFFI - 1) [W]$
 $\theta_{JA} = 64 [^{\circ}C/W]$
 $T_j (\text{Operating junction Temperature}) \leq 125 [^{\circ}C]$
 Operating Ambient Temperature = $T_j - \theta_{JA} \times P_{loss}$

<Reference Pattern Layout>

Top Layer (1)

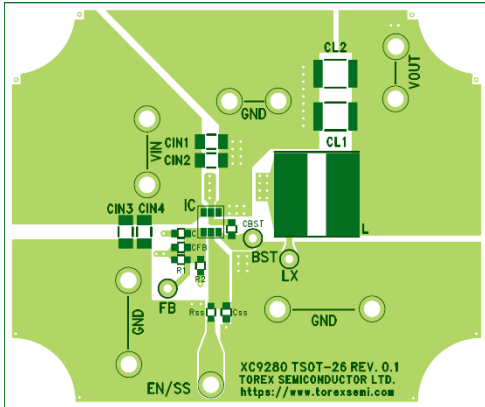

Middle Layer (2,3)



Bottom Layer (4)

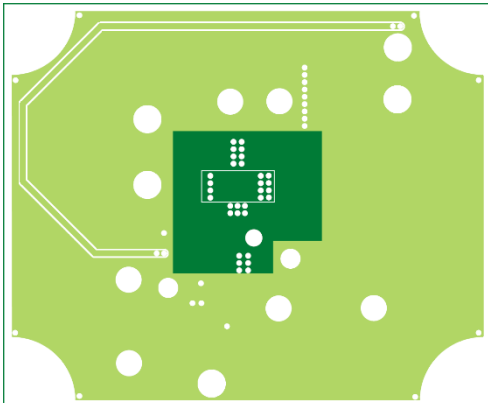

Board : Dimensions 50mm×60mm(4 layer)
 Copper thickness : 35µm
 Material : Glass Epoxy (FR-4)
 Thickness : 1.6mm
 θ_{JA}=64 [°C/W]

TYPICAL PERFORMANCE CHARACTERISTICS

(1) Efficiency vs. Output current

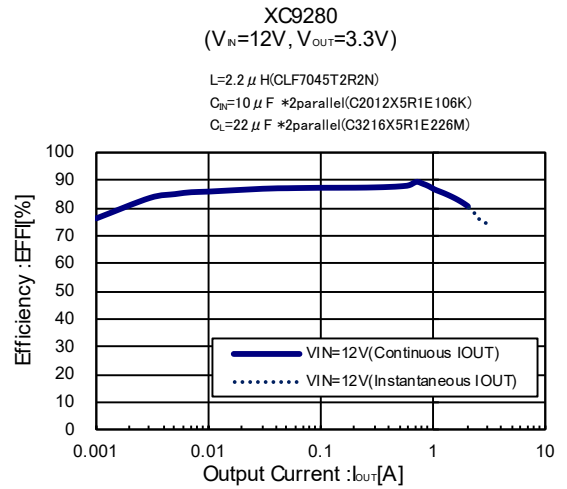
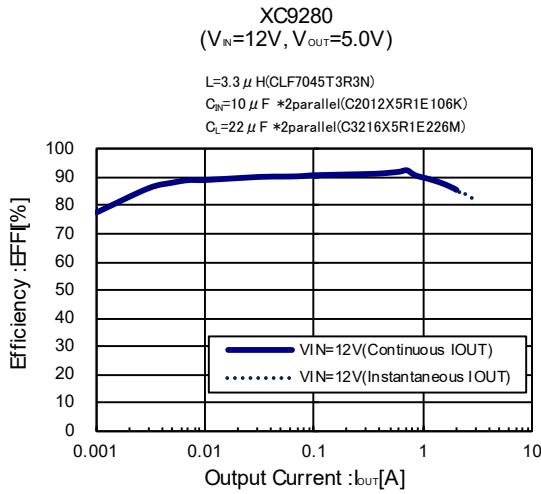

(2) Output Voltage vs. Output Current

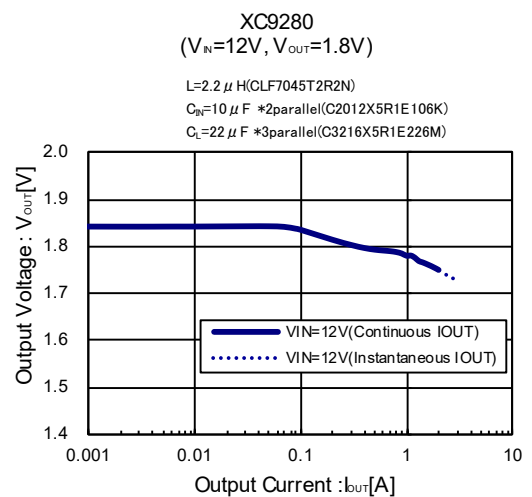
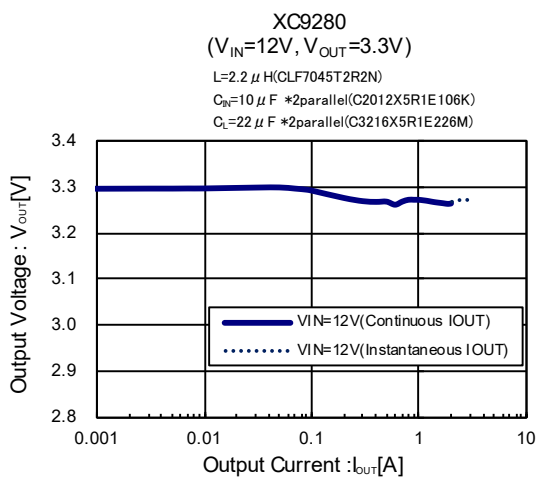
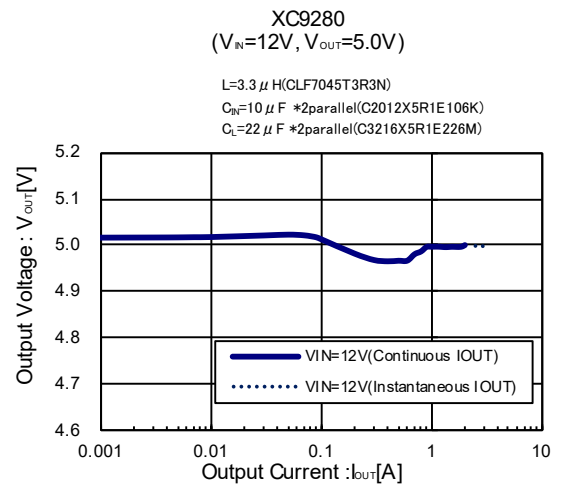
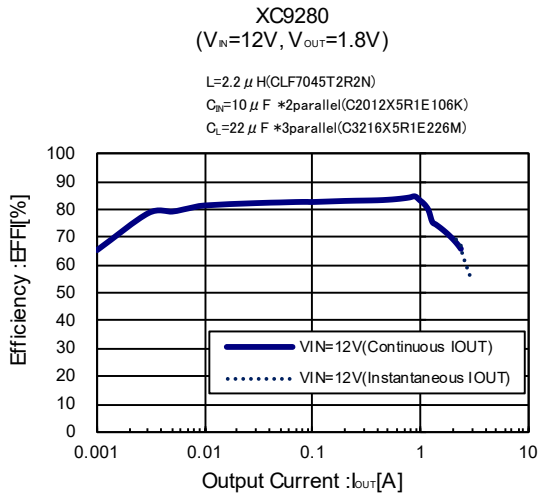

■ TYPICAL PERFORMANCE CHARACTERISTICS (Continued)

(3) Ripple Voltage vs. Output Current

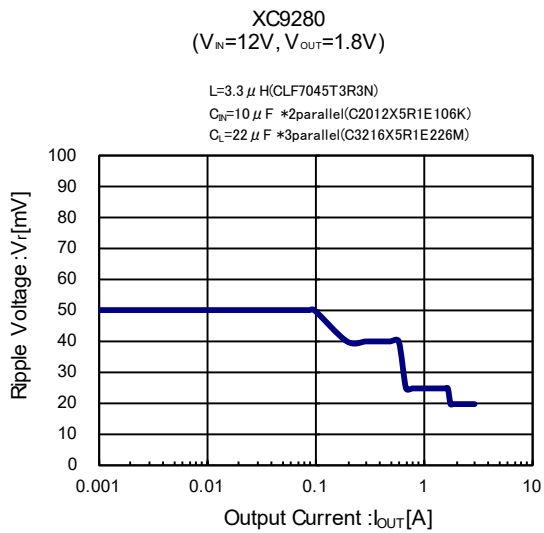
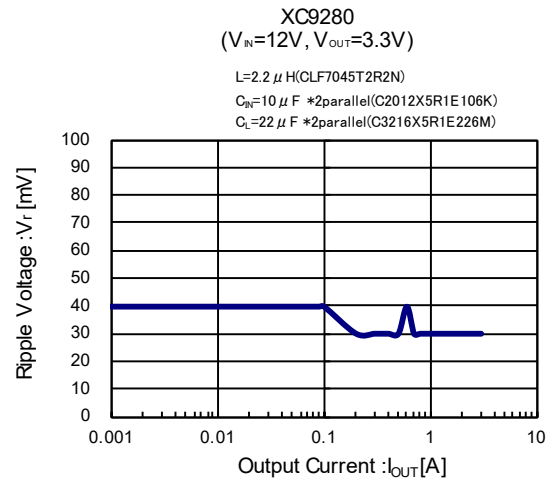
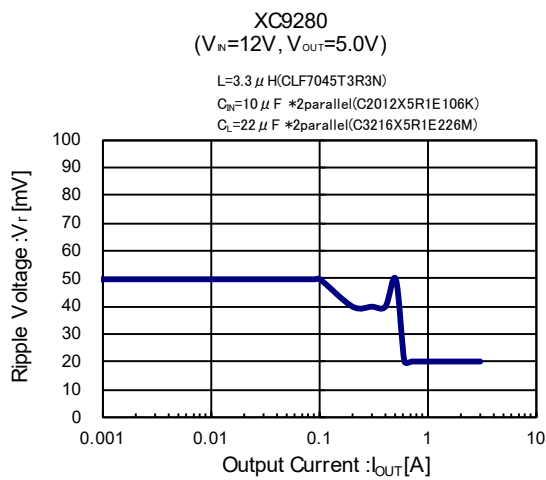

(4) FB Voltage vs. Ambient Temperature

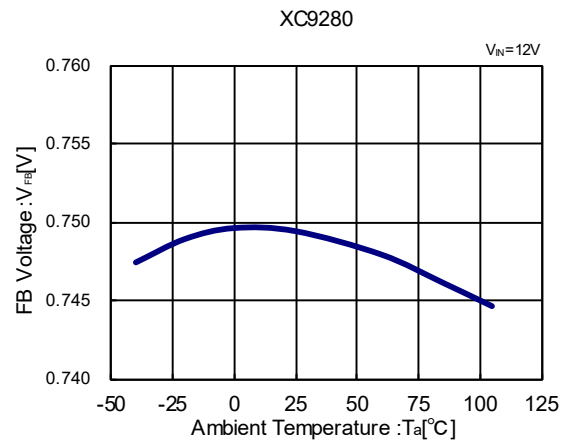

(5) UVLO Voltage vs. Ambient Temperature

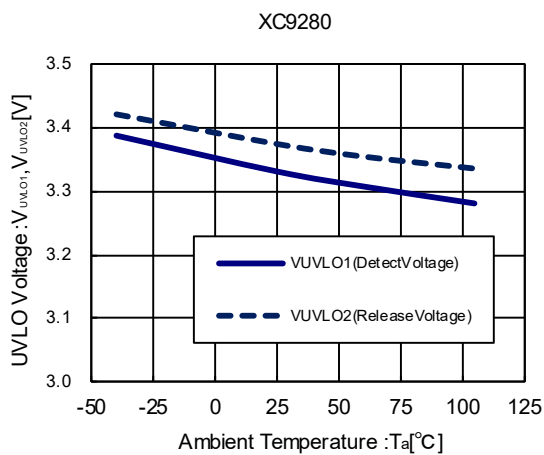

(6) Oscillation Frequency vs. Ambient Temperature

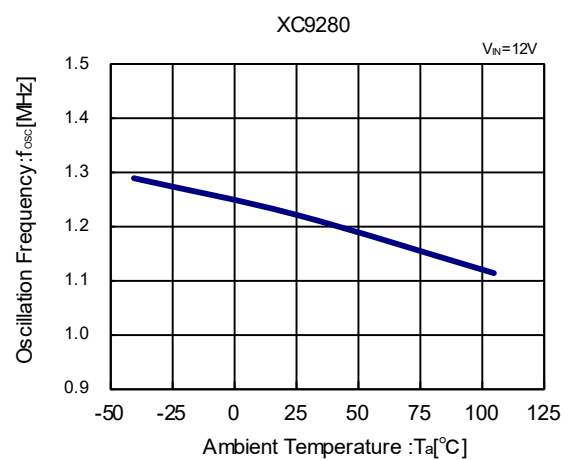

TYPICAL PERFORMANCE CHARACTERISTICS (Continued)

(7) Stand-by Current vs. Ambient Temperature

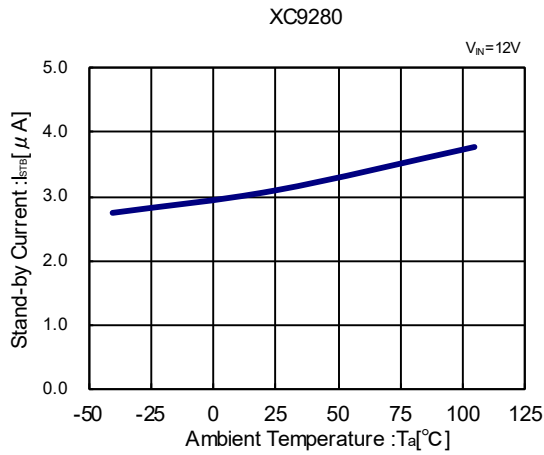

(8) Lx SW ON Resistance vs. Ambient Temperature

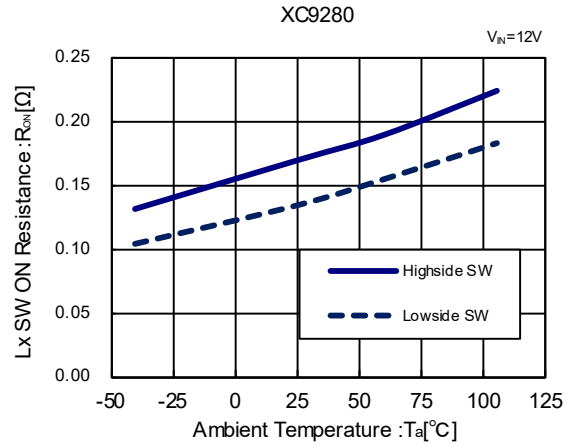

(9) Quiescent Current vs. Ambient Temperature

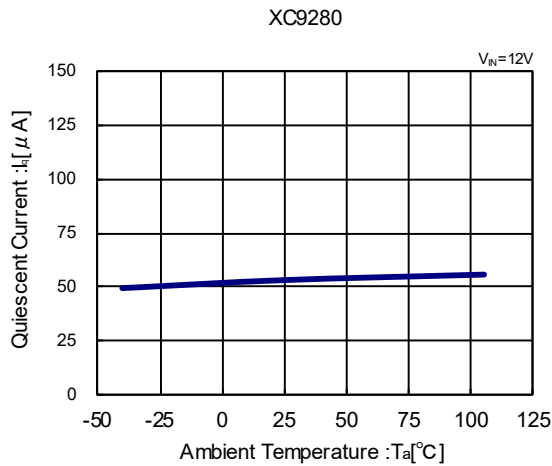

(10) Internal Soft-Start Time vs. Ambient Temperature

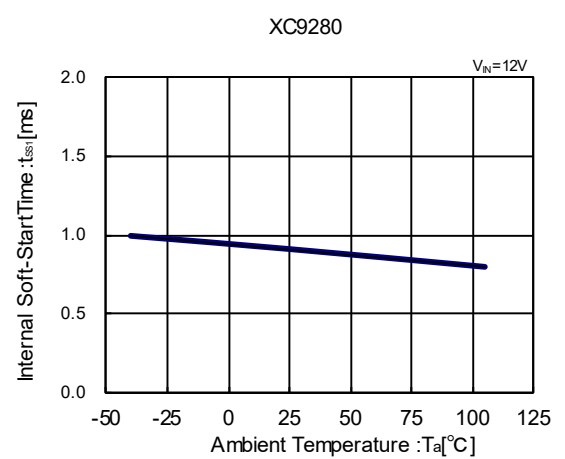

(11) External Soft-Start Time vs. Ambient Temperature

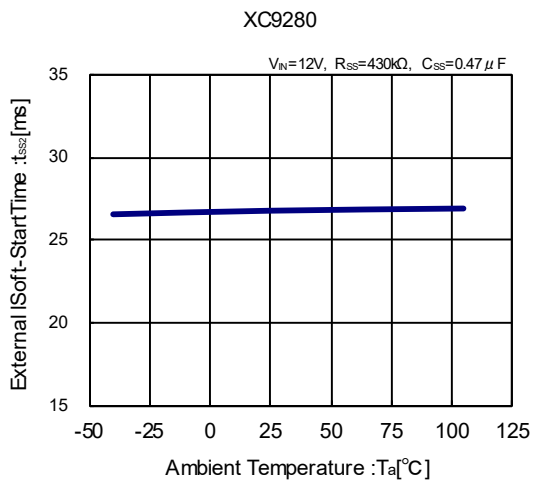

(12) PFM Current vs. Ambient Temperature

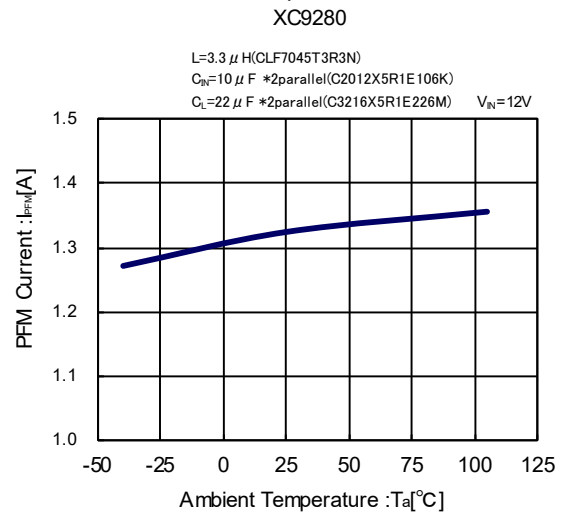

TYPICAL PERFORMANCE CHARACTERISTICS (Continued)

(13) EN/SS Voltage vs. Ambient Temperature

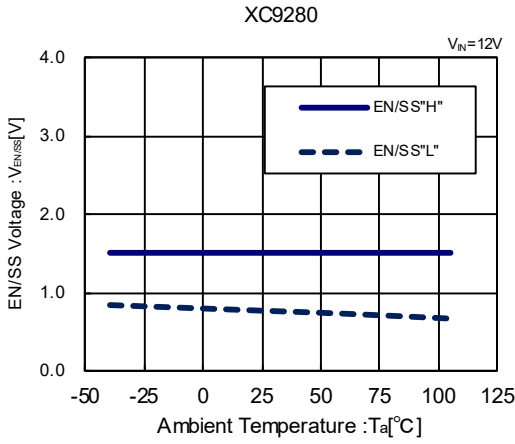

(14) I_{OUT}-V_{IN} Operation Area

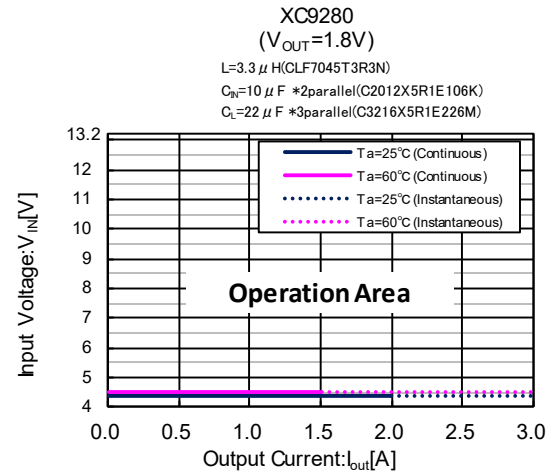
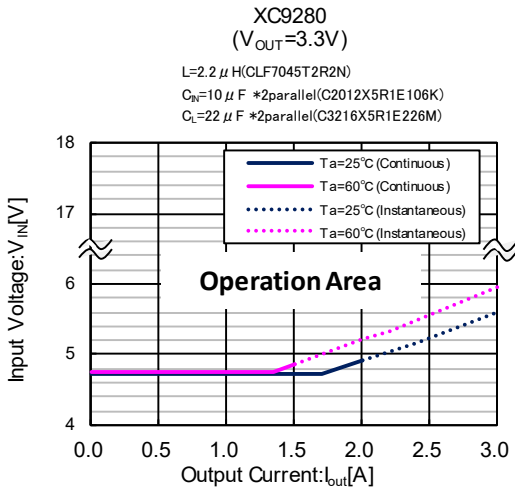
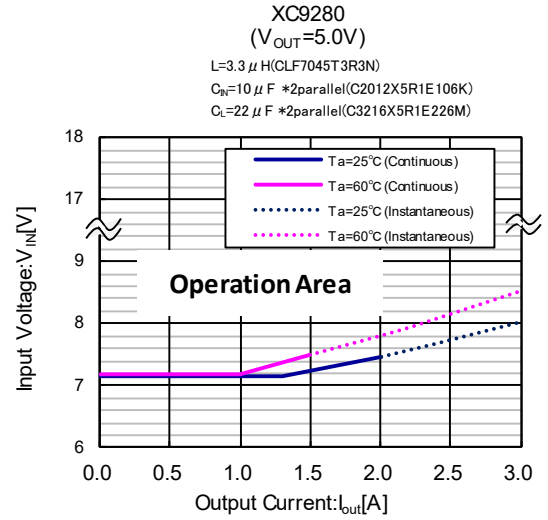

(15) V_{OUT}-V_{IN} Operation Area

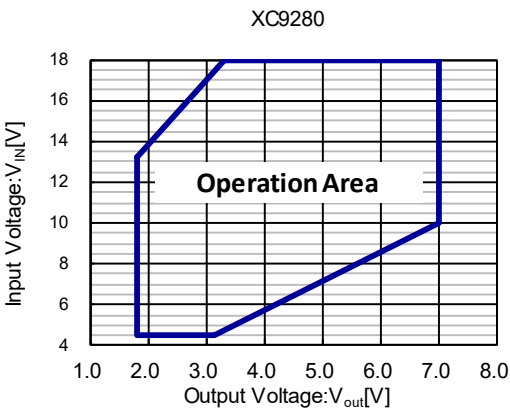

(16) I_{OUT} Transient Operation Area

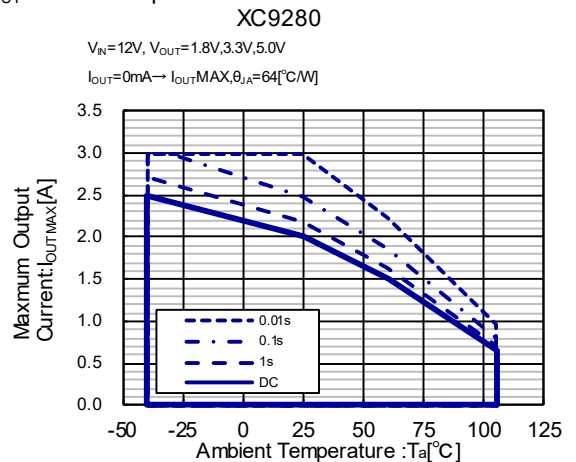

TYPICAL PERFORMANCE CHARACTERISTICS (Continued)

(17-1) Load Transient Response ($V_{OUT}=5.0V$)

XC9280

($V_{IN}=12V$, $V_{OUT}=5.0V$, $I_{OUT}=1.0A \leftrightarrow 2.0A$)

$L=3.3 \mu H$ (CLF7045T3R3N)
 $C_B=10 \mu F$ *2parallel(C2012X5R1E106K)
 $C_L=22 \mu F$ *2parallel(C3216X5R1E226M)

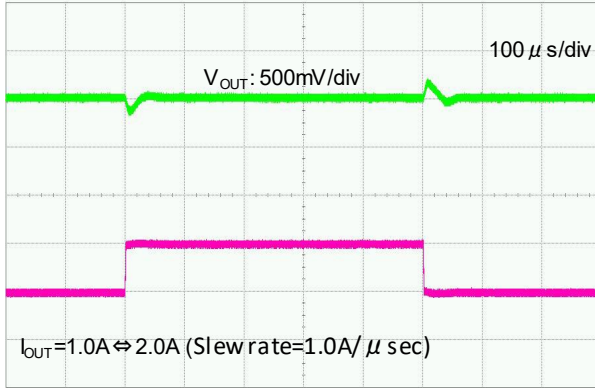

XC9280

($V_{IN}=12V$, $V_{OUT}=5.0V$, $I_{OUT}=0.5A \leftrightarrow 1.5A$)

$L=3.3 \mu H$ (CLF7045T3R3N)
 $C_B=10 \mu F$ *2parallel(C2012X5R1E106K)
 $C_L=22 \mu F$ *2parallel(C3216X5R1E226M)

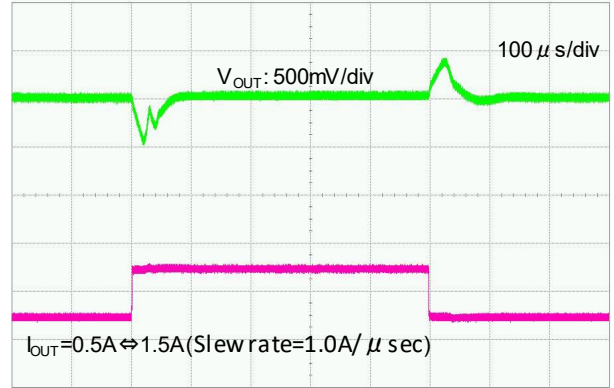

XC9280

($V_{IN}=12V$, $V_{OUT}=5.0V$, $I_{OUT}=1.5A \leftrightarrow 3.0A$)

$L=3.3 \mu H$ (CLF7045T3R3N)
 $C_B=10 \mu F$ *2parallel(C2012X5R1E106K)
 $C_L=22 \mu F$ *2parallel(C3216X5R1E226M)

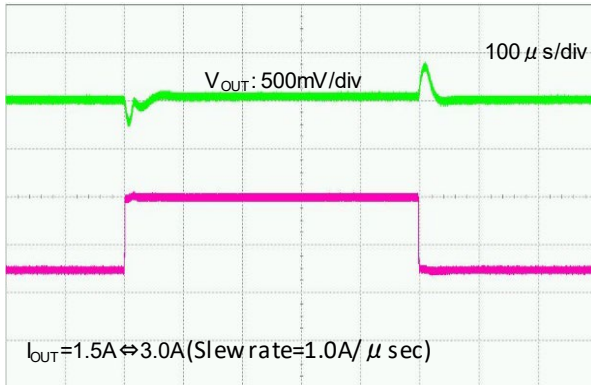

XC9280

($V_{IN}=12V$, $V_{OUT}=5.0V$, $I_{OUT}=0.1A \leftrightarrow 3.0A$)

$L=3.3 \mu H$ (CLF7045T3R3N)
 $C_B=10 \mu F$ *2parallel(C2012X5R1E106K)
 $C_L=22 \mu F$ *2parallel(C3216X5R1E226M)

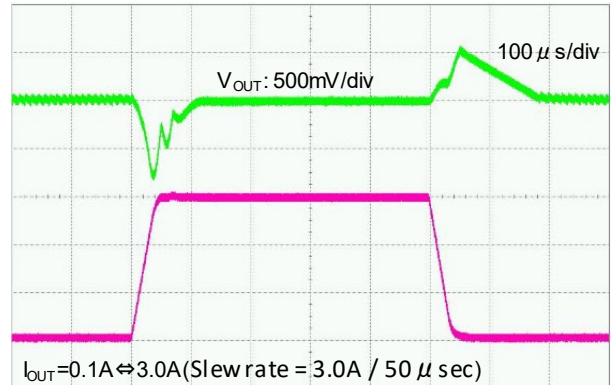

■ TYPICAL PERFORMANCE CHARACTERISTICS (Continued)

(17-2) Load Transient Response ($V_{OUT}=3.3V$)

XC9280
($V_{IN}=12V, V_{OUT}=3.3V, I_{OUT}=1.0A \leftrightarrow 2.0A$)

$L=2.2 \mu H$ (CLF7045T2R2N)
 $C_{IN}=10 \mu F$ *2parallel(C2012X5R1E106K)
 $C_L=22 \mu F$ *2parallel(C3216X5R1E226M)

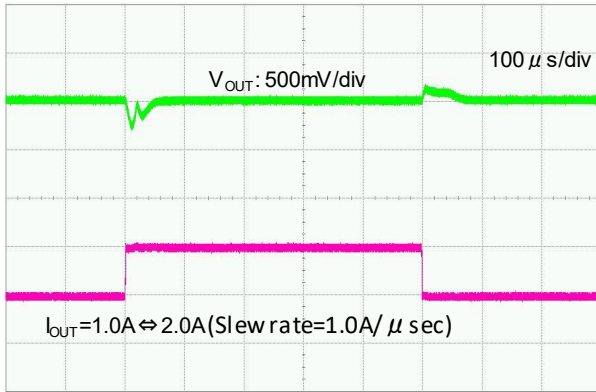

XC9280
($V_{IN}=12V, V_{OUT}=3.3V, I_{OUT}=0.5A \leftrightarrow 1.5A$)

$L=2.2 \mu H$ (CLF7045T2R2N)
 $C_{IN}=10 \mu F$ *2parallel(C2012X5R1E106K)
 $C_L=22 \mu F$ *2parallel(C3216X5R1E226M)

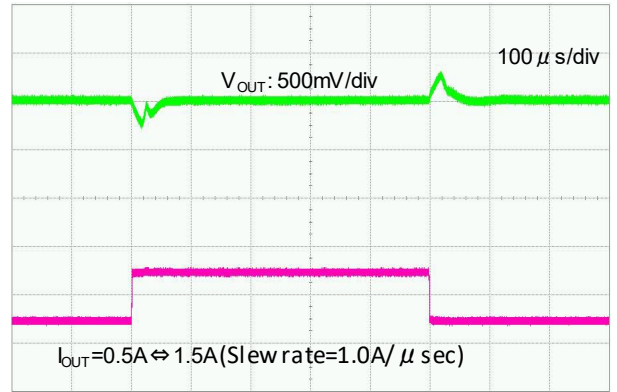

XC9280
($V_{IN}=12V, V_{OUT}=3.3V, I_{OUT}=1.5A \leftrightarrow 3.0A$)

$L=2.2 \mu H$ (CLF7045T2R2N)
 $C_{IN}=10 \mu F$ *2parallel(C2012X5R1E106K)
 $C_L=22 \mu F$ *2parallel(C3216X5R1E226M)

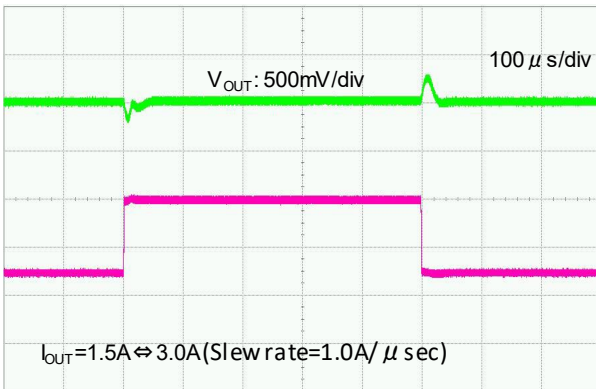

XC9280
($V_{IN}=12V, V_{OUT}=3.3V, I_{OUT}=0.1A \leftrightarrow 3.0A$)

$L=2.2 \mu H$ (CLF7045T2R2N)
 $C_{IN}=10 \mu F$ *2parallel(C2012X5R1E106K)
 $C_L=22 \mu F$ *2parallel(C3216X5R1E226M)



TYPICAL PERFORMANCE CHARACTERISTICS (Continued)

(17-3) Load Transient Response ($V_{OUT}=1.8V$)

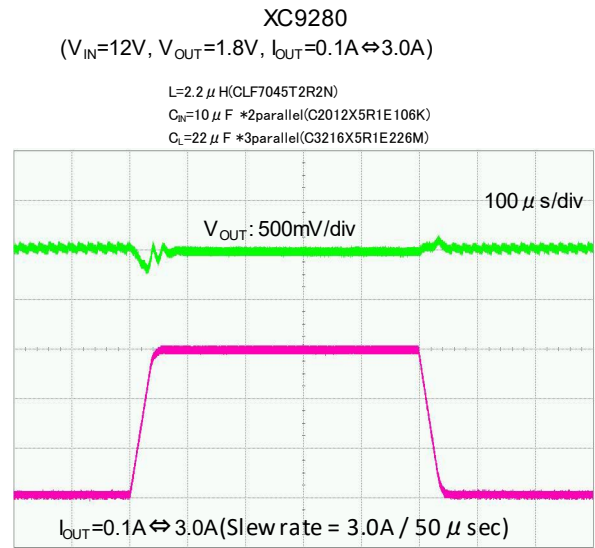
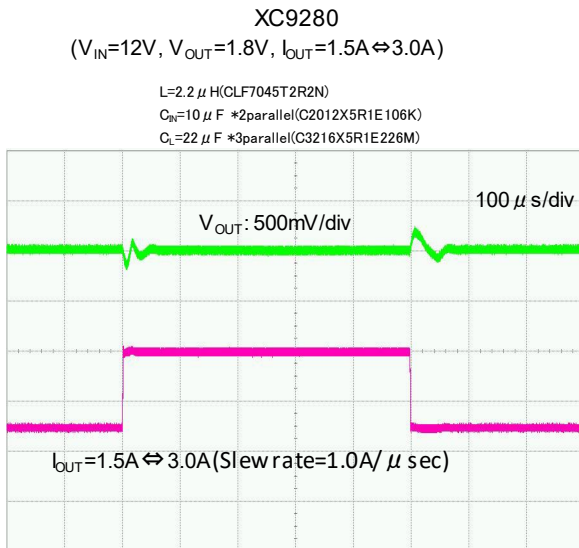
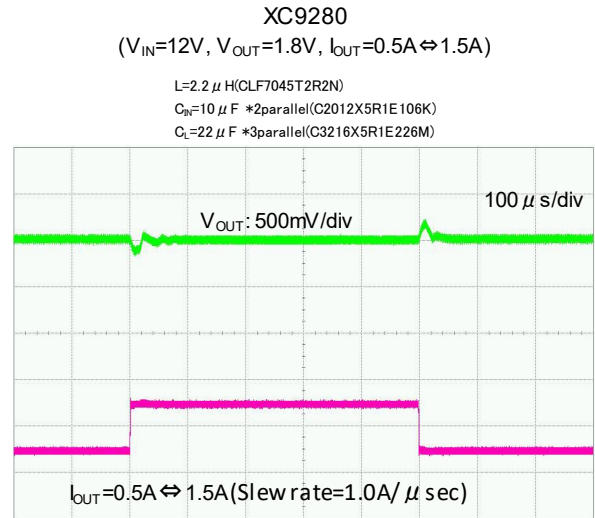
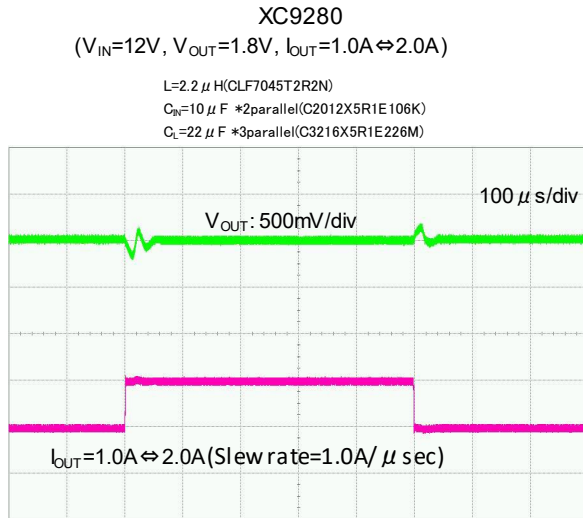

■ TYPICAL PERFORMANCE CHARACTERISTICS (Continued)

(18) Input Transient Response

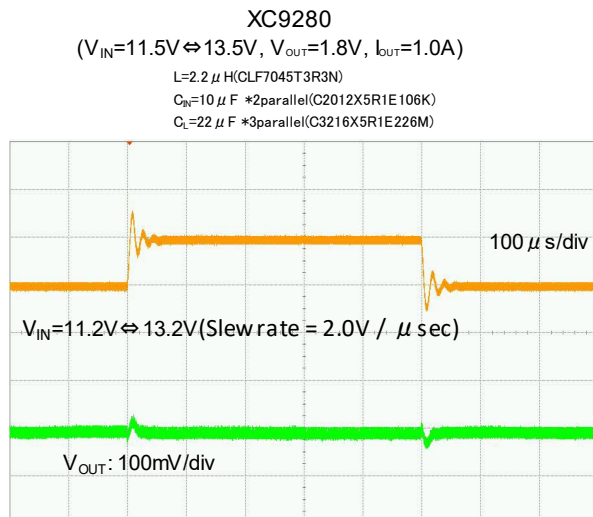
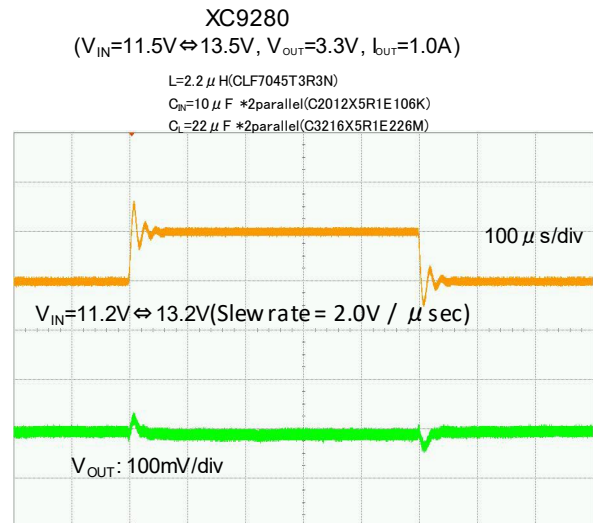
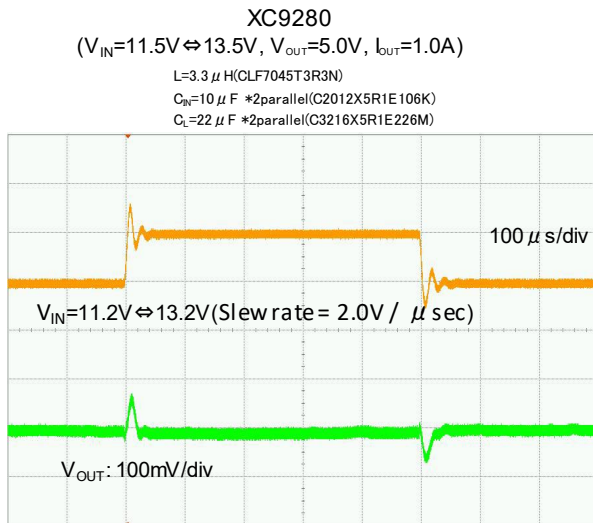

TYPICAL PERFORMANCE CHARACTERISTICS (Continued)

(19) EN/SS Rising Response

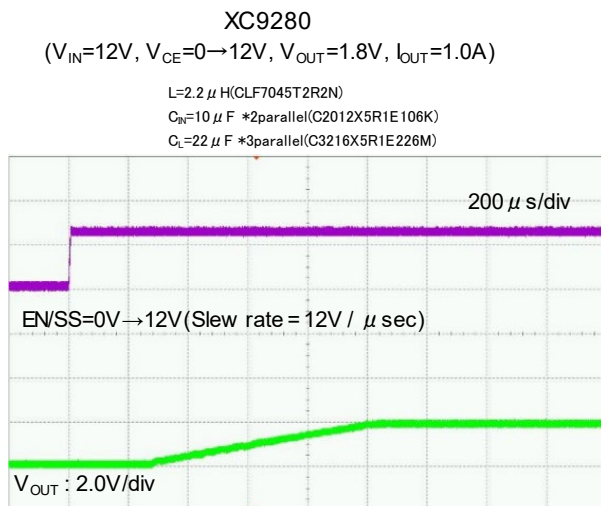
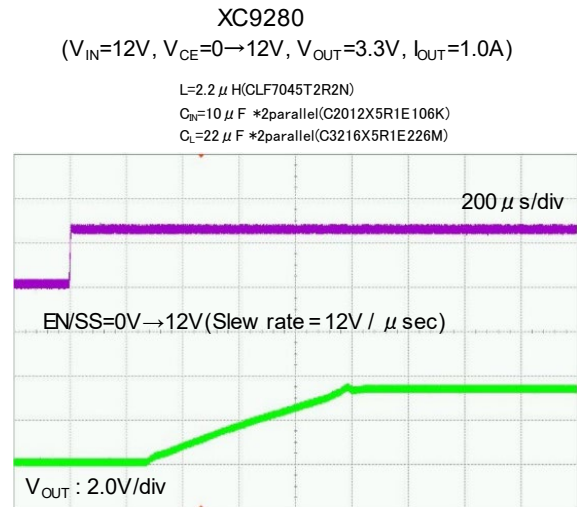
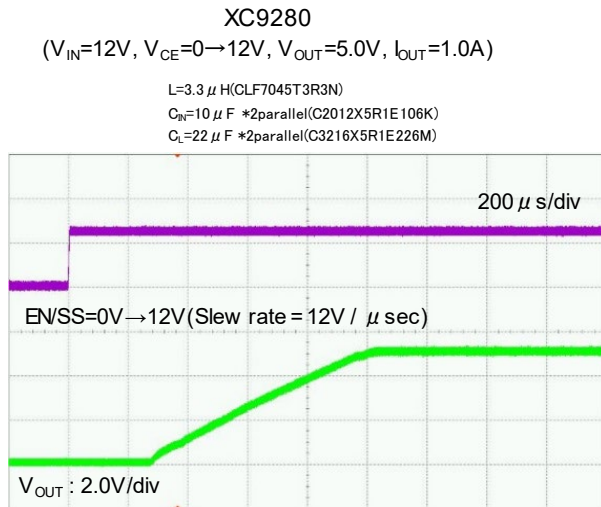

TYPICAL PERFORMANCE CHARACTERISTICS (Continued)

(20) Output Voltage vs. Output Current

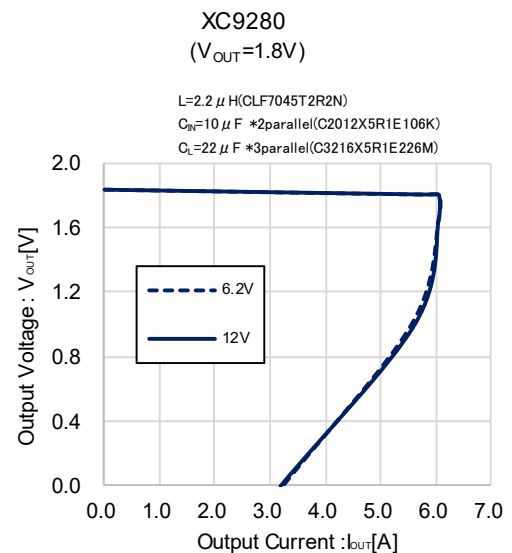
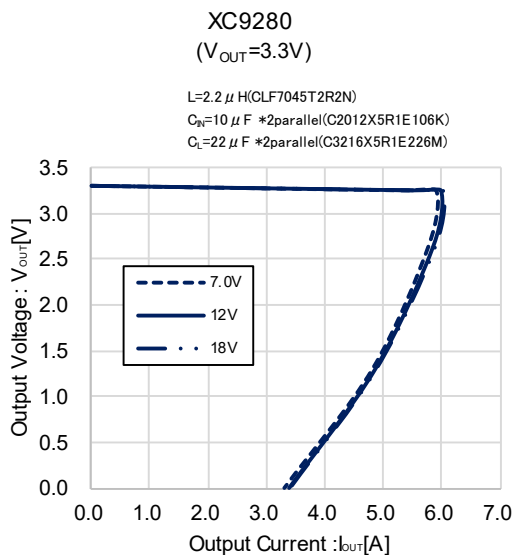
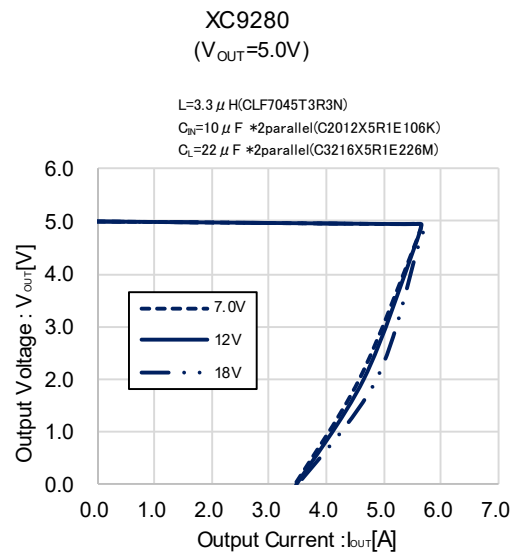
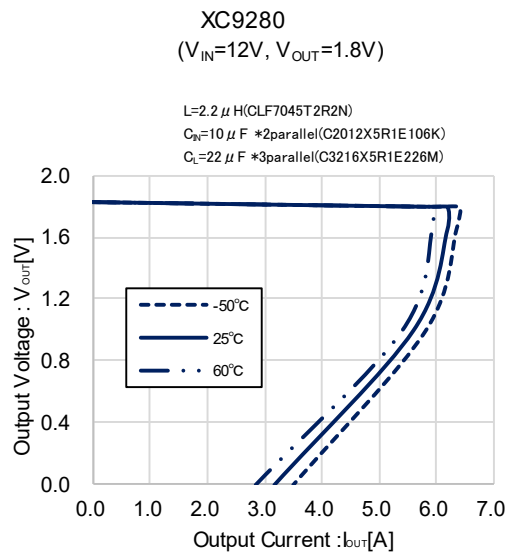
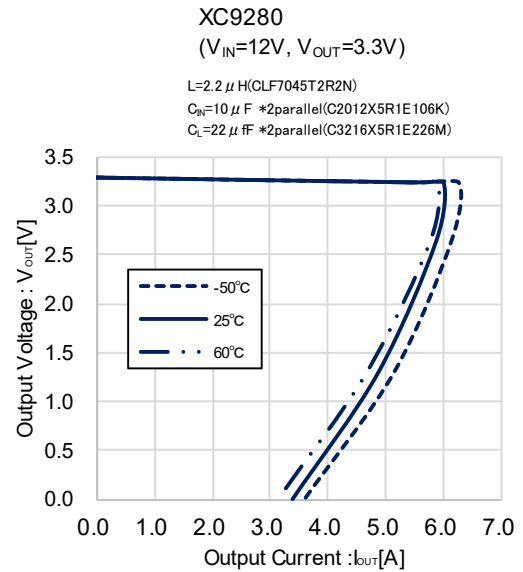
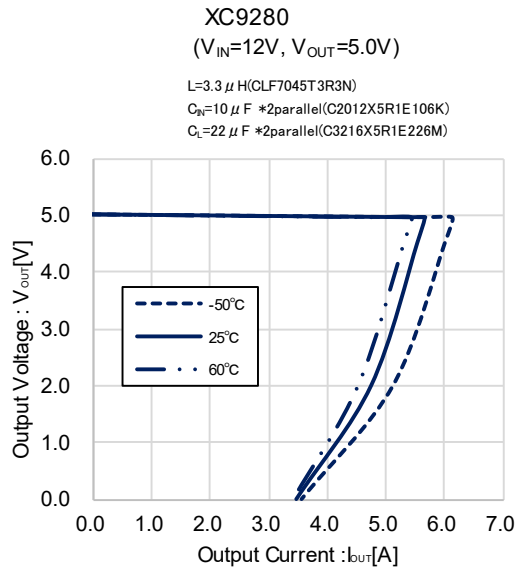

■ PACKAGING INFORMATION

For the latest package information go to, www.torexsemi.com/technical-support/packages

PACKAGE	OUTLINE / LAND PATTERN	THERMAL CHARACTERISTICS
TSOT-26	TSOT-26 PKG	TSOT-26 Power Dissipation

MARKING RULE

TSOT-26

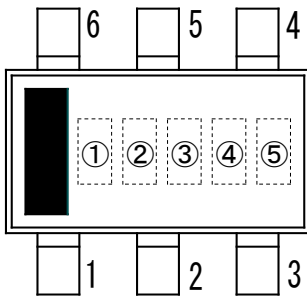

①,②,③ Type, Oscillation Frequency

Mark			Type	Oscillation Frequency	Product Series
①	②	③			
1	1	A	A	1.2MHz	XC9280A75CYR-G

④,⑤ represents production lot number

01~09, 0A~0Z, 11~9Z, A1~A9, AA~AZ, B1~ZZ repeated
(G, I, J, O, Q, W excluded)* No character inversion used.

1. The product and product specifications contained herein are subject to change without notice to improve performance characteristics. Consult us, or our representatives before use, to confirm that the information in this datasheet is up to date.
2. The information in this datasheet is intended to illustrate the operation and characteristics of our products. We neither make warranties or representations with respect to the accuracy or completeness of the information contained in this datasheet nor grant any license to any intellectual property rights of ours or any third party concerning with the information in this datasheet.
3. Applicable export control laws and regulations should be complied and the procedures required by such laws and regulations should also be followed, when the product or any information contained in this datasheet is exported.
4. The product is neither intended nor warranted for use in equipment of systems which require extremely high levels of quality and/or reliability and/or a malfunction or failure which may cause loss of human life, bodily injury, serious property damage including but not limited to devices or equipment used in 1) nuclear facilities, 2) aerospace industry, 3) medical facilities, 4) automobile industry and other transportation industry and 5) safety devices and safety equipment to control combustions and explosions. Do not use the product for the above use unless agreed by us in writing in advance.
5. Although we make continuous efforts to improve the quality and reliability of our products; nevertheless Semiconductors are likely to fail with a certain probability. So in order to prevent personal injury and/or property damage resulting from such failure, customers are required to incorporate adequate safety measures in their designs, such as system fail safes, redundancy and fire prevention features.
6. Our products are not designed to be Radiation-resistant.
7. Please use the product listed in this datasheet within the specified ranges.
8. We assume no responsibility for damage or loss due to abnormal use.
9. All rights reserved. No part of this datasheet may be copied or reproduced unless agreed by Torex Semiconductor Ltd in writing in advance.

TOREX SEMICONDUCTOR LTD.