

MReX-PCB User Guide V1.02

MReX-PCB Mini Transmitter

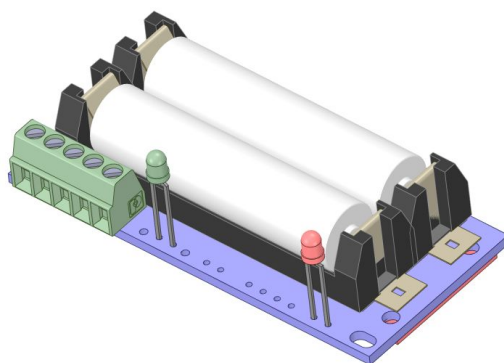

User Guide

MReX-PCB User Guide V1.02

Table of Contents

Introduction.....	3
Electrical.....	4
PCB Pinout.....	5
Programming the MReX Module.....	6
Inputs.....	6
LEDs Outputs.....	7
LED/Piezo Resistor Configuration.....	8
Piezo connection.....	10
Physical Dimensions.....	12
Disclaimer.....	13

MReX-PCB User Guide V1.02

Introduction

This user guide describes configuration and use of the WTE MReX-PCB. This PCB allows simple integration into a system and incorporates the MReX-460 Module. For command use and detailed operation, consult the MReX-460 User Manual. Not shown is the antenna connection. This may be an SMA connector fitted to the red MReX-460 module (with antenna) or a 16cm wire (one quarter the wavelength of the frequency of operation).

MReX-PCB User Guide V1.02

Electrical

The following schematic shows how the MReX-460 module is routed to connection pads.

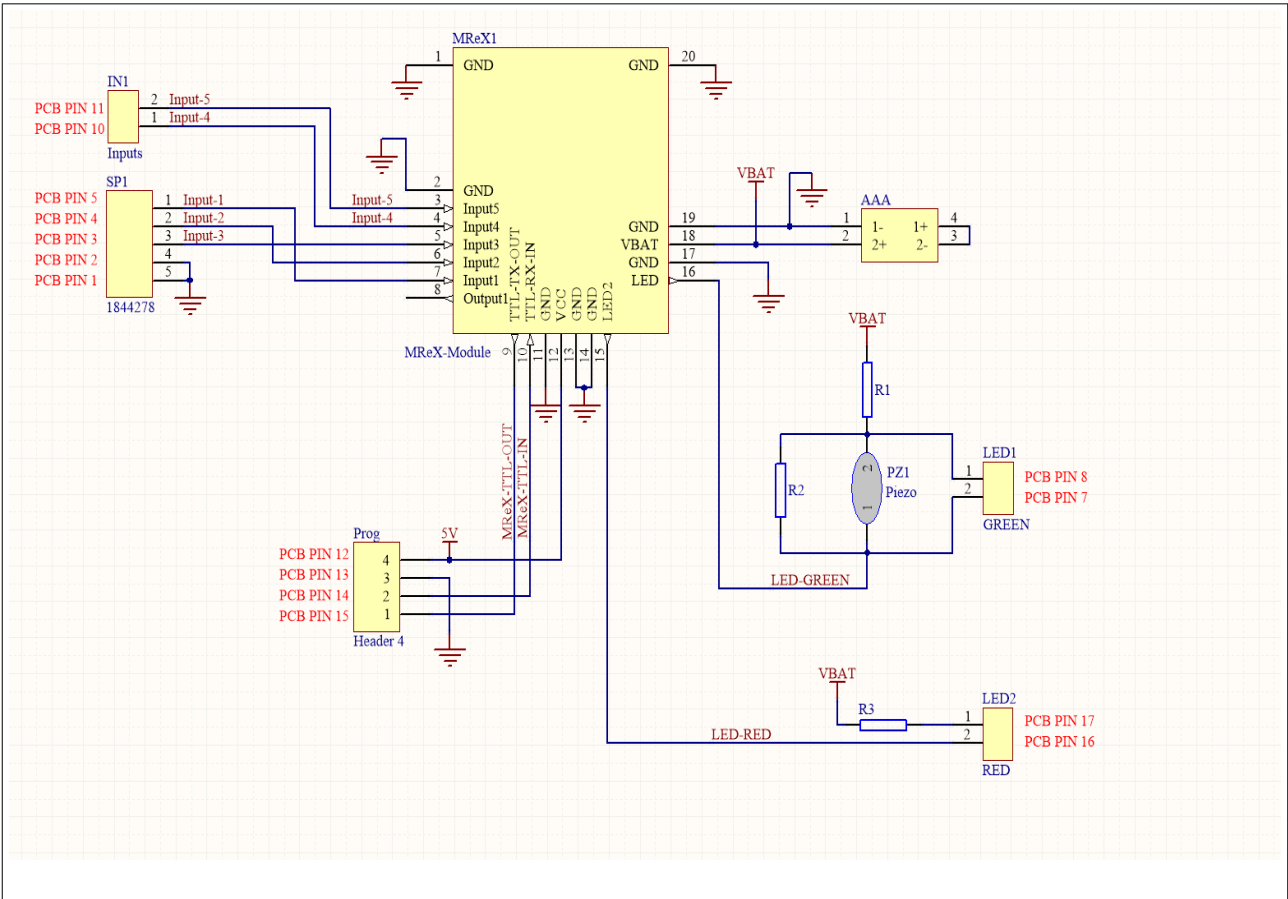

MReX-PCB User Guide V1.02

PCB Pinout

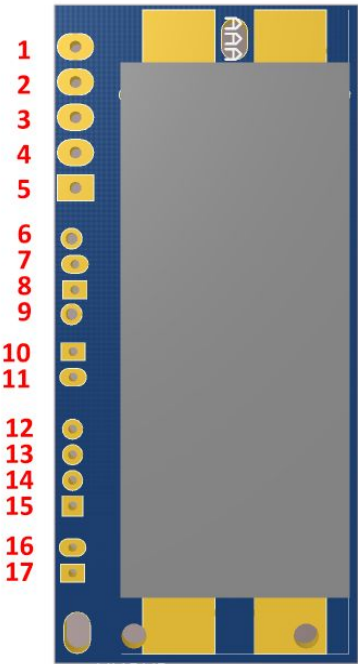
	Pin #	Description
	1	GND
	2	GND
	3	Contact Input 3 (Connection to input must be volt free). Pull to GND to operate.
	4	Contact Input 2 (Connection to input must be volt free). Pull to GND to operate.
	5	Contact Input 1 (Connection to input must be volt free). Pull to GND to operate.
	6	Piezo. This pin is electrically tied to pin 7
	7	Green LED – Cathode (open drain output)
	8	Green LED + Anode (not connected if LED is powered externally)
	9	Piezo. This pin is electrically tied to pin 8
	10	Contact Input 4 (Connection to input must be volt free). Pull to GND to operate.
	11	Contact Input 5 (Connection to input must be volt free). Pull to GND to operate.
	12	Programming VCC
	13	GND
	14	Serial TTL IN
	15	Serial TTL OUT
	16	Red LED – Cathode (open drain output)
17	Red LED + Anode (not connected if LED is powered externally)	

MReX-PCB User Guide V1.02

Programming the MReX Module

The Programming Header contains a 5V (VCC) pin which can be used to power the MReX Module for loading configuration or uploading new firmware.

Do NOT apply voltage to this pin if batteries are fitted.



Note: Serial connection is 3.3V TTL. The MReX-PROG USB to serial adaptor can be provided for serial interfacing.

Inputs

Refer to the MReX Module manual (Input Hardware Connection) for example of connections

MReX-PCB User Guide V1.02

LEDs Outputs

Connecting the LEDs using Open Drain (bypassing PCB resistors)

The LED outputs are open drain/collectors suitable for sinking a maximum of 50mA. The example is being used to drive an LED from an external supply. Should the output be presented to potential ESD conditions (such as any terminal screw or external connection), ESD devices should be fitted. If the output is to be used to control a small relay, it is essential that a flyback diode is fitted across the coil of the relay.

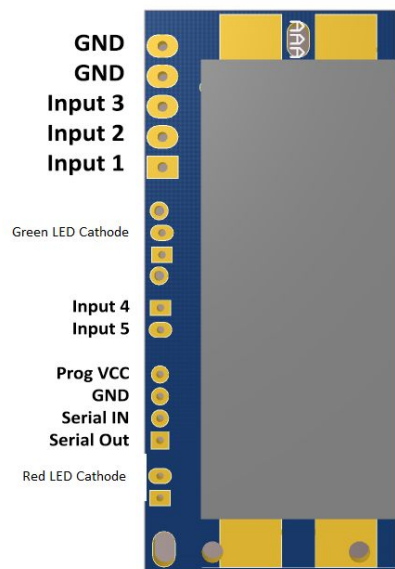
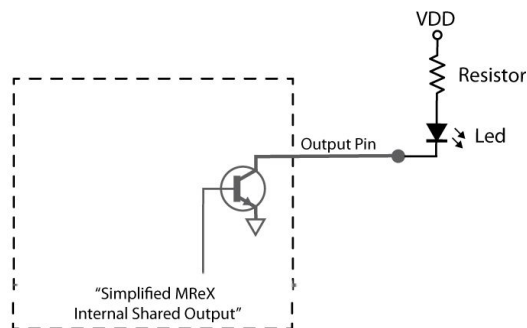

Only the Cathode connections of the LEDs are shown here. They are connected to an open drain output. As shown in the simplified schematic above, it is the users responsibility to select a resistor that suits the application, and then connect to a suitable power source that has a common GND.

MReX-PCB User Guide V1.02

LED/Piezo Resistor Configuration

The following resistor configuration information describes how to modify the MReX-PCB if LEDs are to be used powered directly from the fitted AAA battery pack, or how to fit a piezo sounder (and required components).

R1 is used to limit current through the green LED/Piezo. Typical LED value resistor value from 220R to 470R. When a piezo sounder is fitted R1 = 47R.

R2 is used by the piezo to improve audio response (1K typically). The resistor fitted should ideally be selected to produced the greatest audio output.

R3 is used to limit current through the Red LED. Typical LED value resistor value from 220R to 470R.

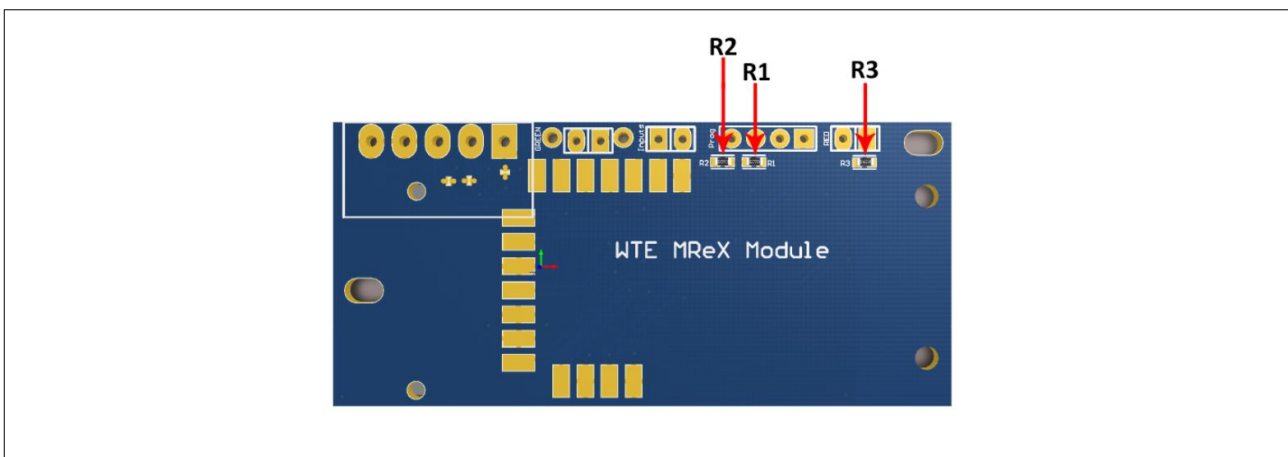

When the command `*RX_ENABLE=0` is sent to the MReX (disabling the receiver), the green LED operation changes so that instead of flashing once a second, this output is modulated, so that when connected to a piezo sounder, a beep will be heard prior to input activated transmissions.

MReX-PCB User Guide V1.02

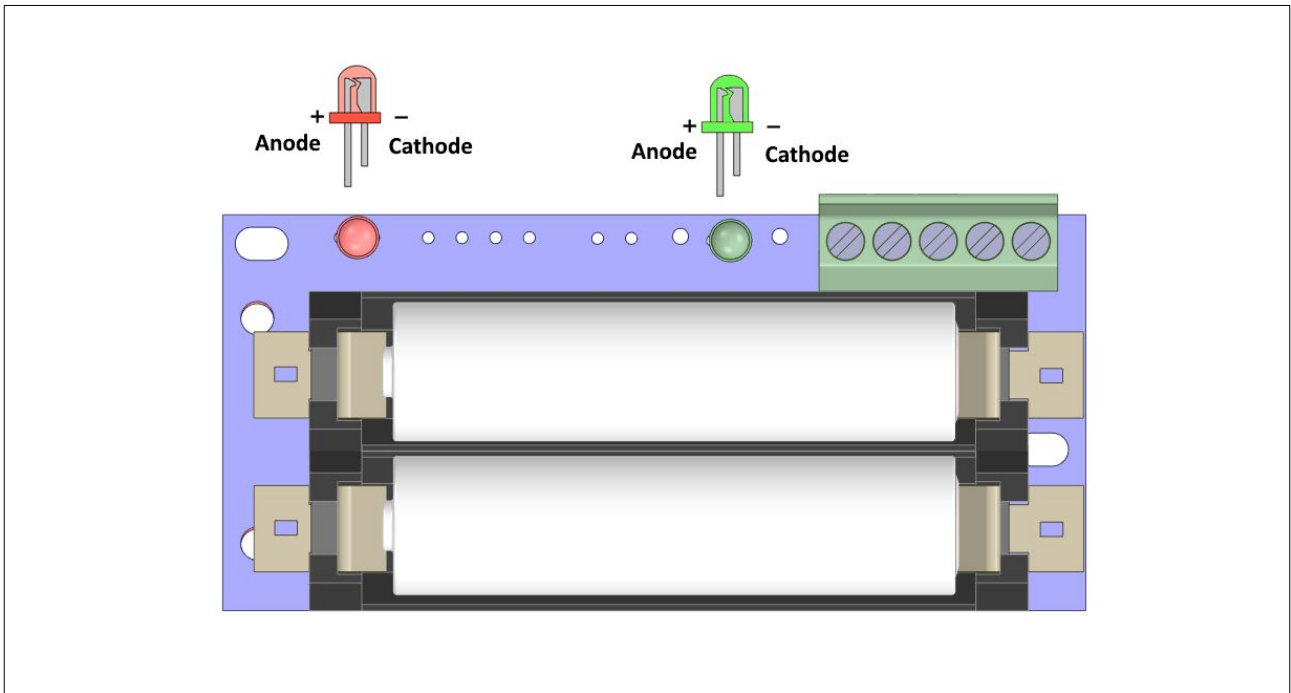

MReX-PCB User Guide V1.02

Piezo connection

The following images guide the connection of the piezo and required resistors.

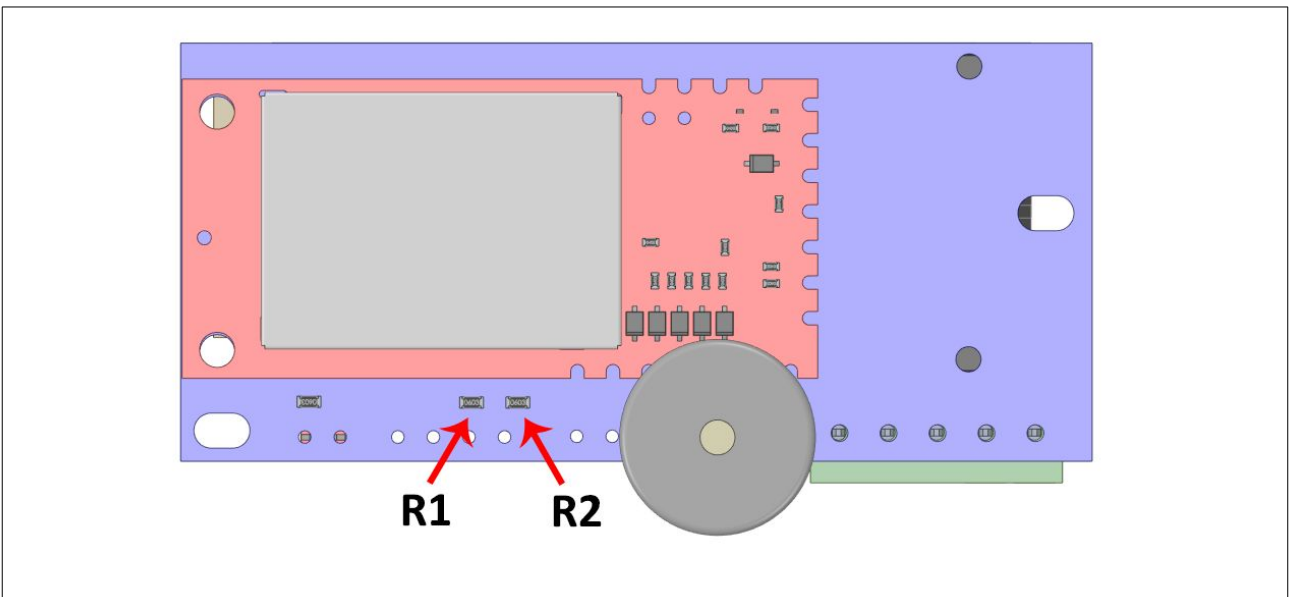
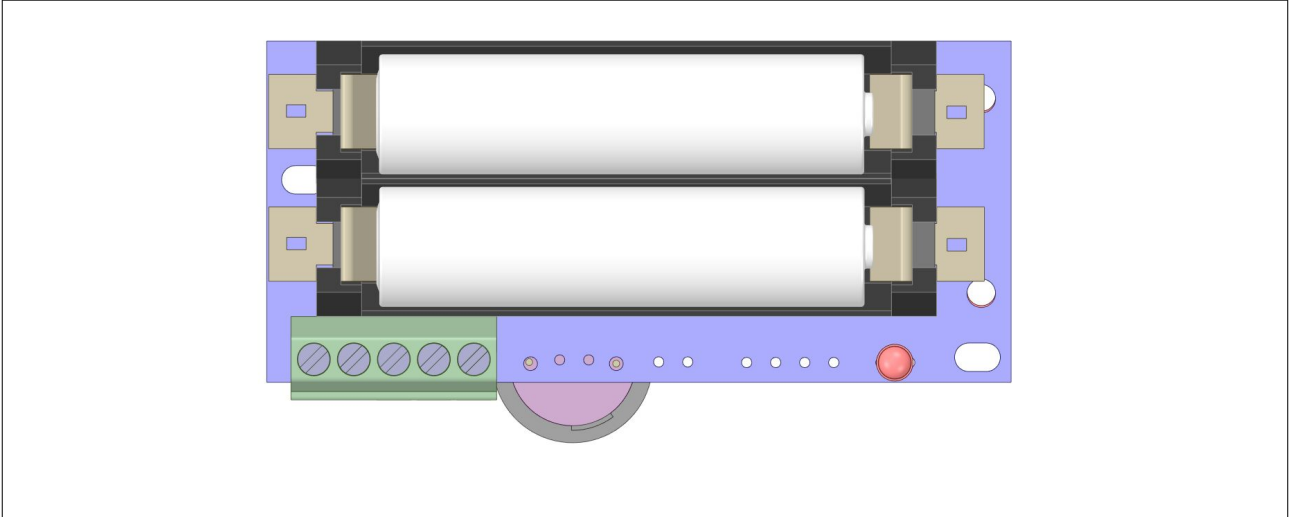

MReX-PCB User Guide V1.02

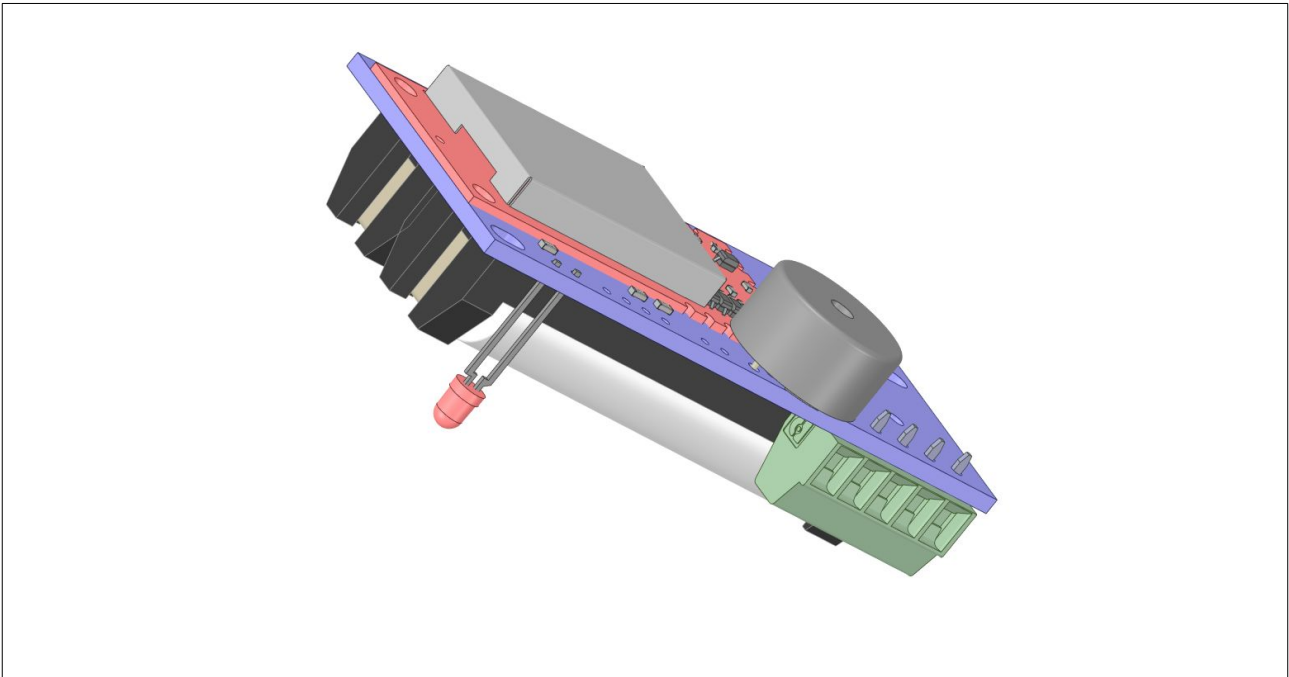

MReX-PCB User Guide V1.02

Physical Dimensions

Overall board dimensions

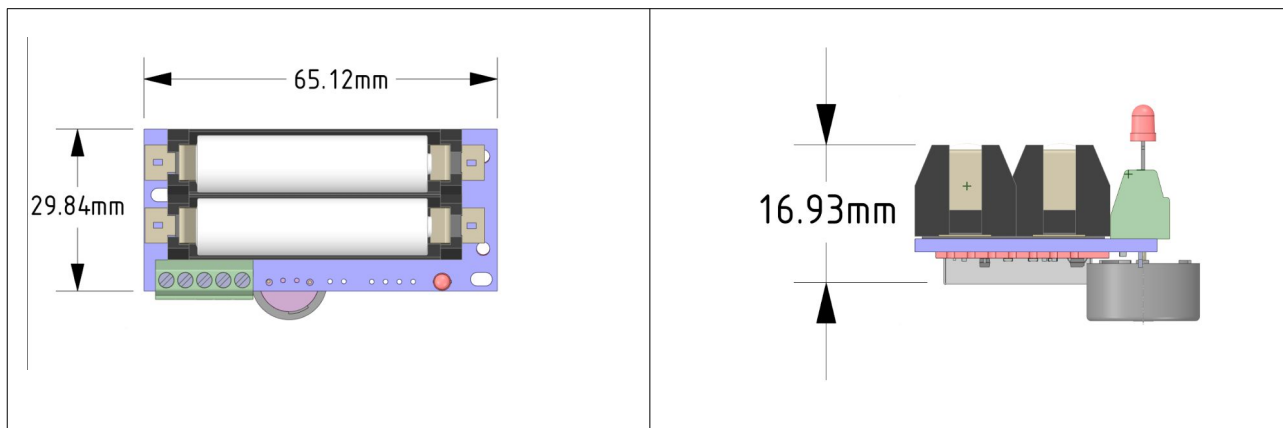

MReX-PCB User Guide V1.02

Disclaimer

THE RESPONSIBILITY LIES COMPLETELY ON THE USER TO ENSURE THAT THIS DEVICE IS TESTED, THROUGH METHODS THAT ARE APPROPRIATE, TO CONFIRM THAT ALL SYSTEM COMPONENTS (THAT THIS DEVICE AND PC SOFTWARE MAY BE PART OF) ARE WORKING CORRECTLY.

This document has been prepared in good faith and produced to assist in the use of this product, however WTE Limited reserves the right to modify, add or remove features without notice.

Please note that the maximum permitted transmit power level may vary from country to country. It is the users responsibility to ensure local regulations are adhered to.

When product is supplied, it is the user who is responsible for payment of any customs fees/taxes that are imposed on importation.

No User-Serviceable Components. There are no user-serviceable components within the product.

RoHS and WEEE Compliance

MReX is fully compliant with the European Commission's RoHS (Restriction of Certain Hazardous Substances in Electrical and Electronic Equipment) and WEEE (Waste Electrical and Electronic Equipment) environmental directives.

Restriction of hazardous substances (RoHS)

The RoHS Directive prohibits the sale in the European Union of electronic equipment containing these hazardous substances: lead, cadmium, mercury, hexavalent chromium, polybrominated biphenyls (PBBs), and polybrominated diphenyl ethers (PBDEs).

End-of-life recycling programme (WEEE)

The WEEE Directive concerns the recovery, reuse, and recycling of electronic and electrical equipment. Under the Directive, used equipment must be marked, collected separately, and disposed of properly.