

Customer Information Sheet

DRAWING No.: S03-XXXXXXXOR

IF IN DOUBT - ASK

©

NOT TO SCALE

THIRD ANGLE PROJECTION

ALL DIMENSIONS IN mm

EMBOSSED HARWIN LOGO
NO THROUGH CUT.

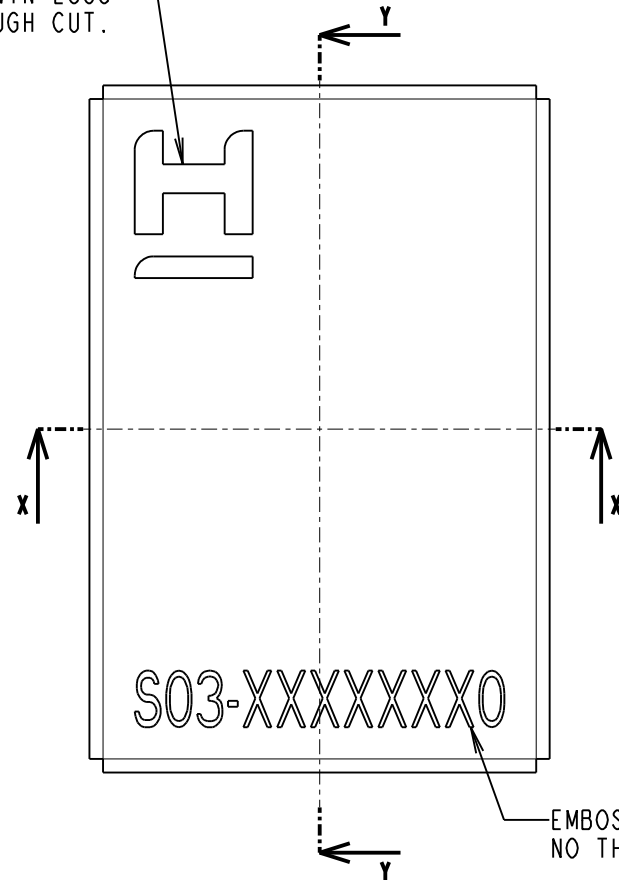

EMBOSSED PART NUMBER (SEE ORDER CODE).
NO THROUGH CUT.

SECTION Y-Y

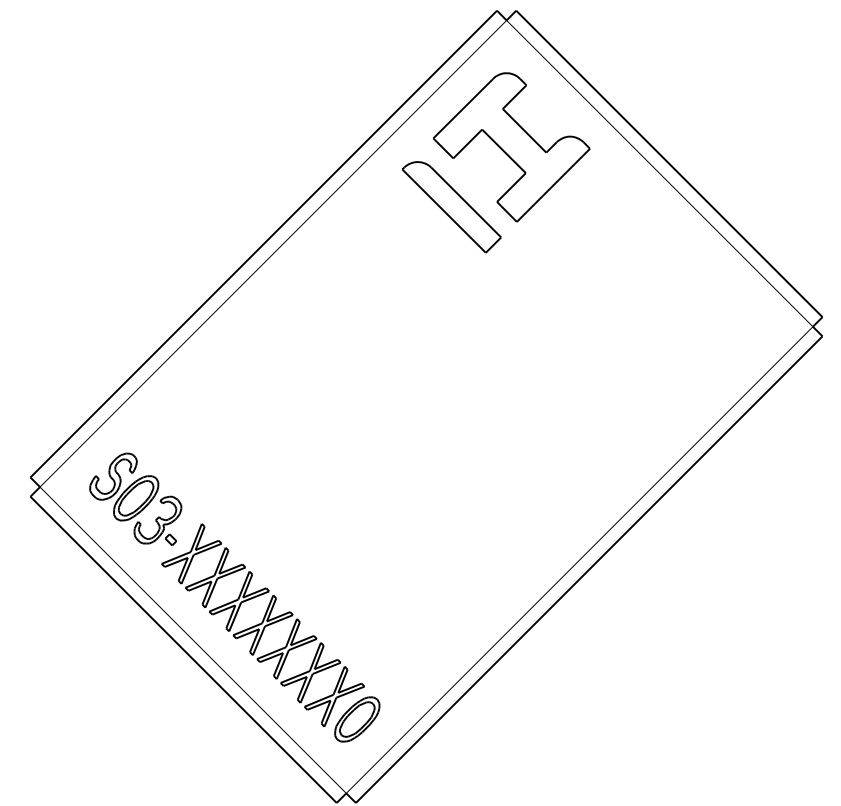
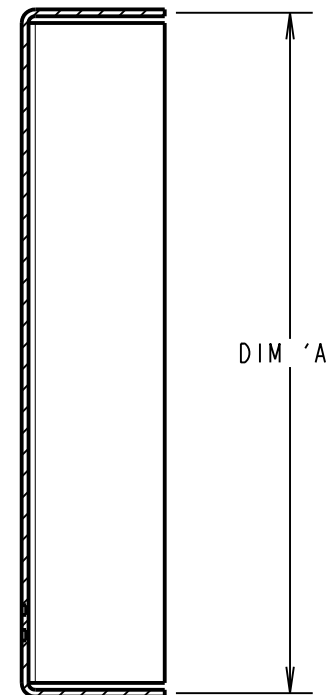

VIEW SHOWING CORNER OF
THE SHIELD CAN

SECTION X-X

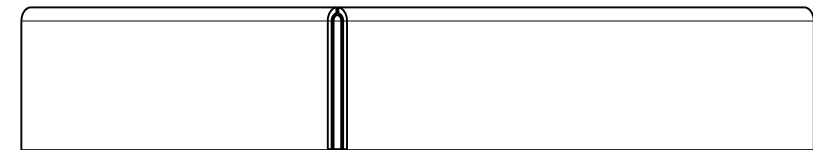
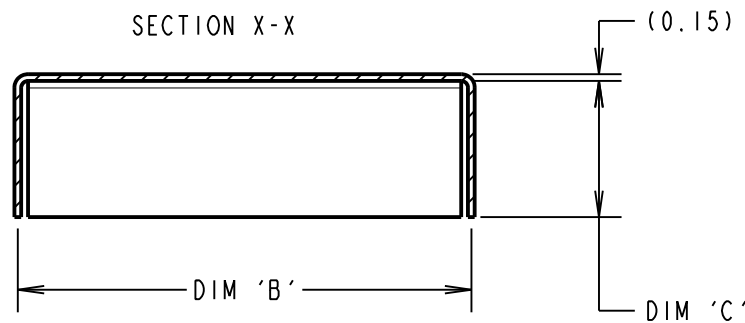

NOTES:

1. DIM 'C', HEIGHT OF THE CAN IS FROM THE BOTTOM EDGE TO THE INSIDE OF THE TOP FACE.
2. BOTH DIM 'A' AND 'B' ARE FROM THE CENTRE OF THE MATERIAL THICKNESS.
3. SHIELD CAN IS RECOMMENDED FOR USE WITH RFI SHIELD CLIPS: S0911-46R, S1001-46R, S0941-46R, S0961-46R AND S1721-46R.
4. SEE SHEET 4 FOR TAPE AND REEL DETAILS.

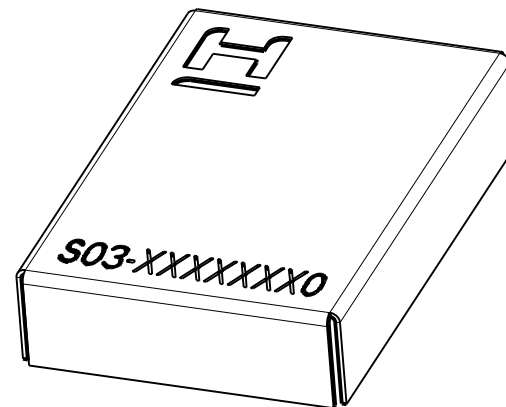

ORDER CODE:

S03-XXXXXXXOR

SIZE:

DIM 'A' = LENGTH
DIM 'B' = WIDTH
DIM 'C' = HEIGHT

FINISH:

0 = UNPLATED FINISH

PACKING:

R = TAPE AND REEL (SEE SHEET 4)

MR	4	09.10.19	22118
NAME	ISS.	DATE	C/NOTE
APPROVED: M.RUDKIN			
CHECKED: S.BENNETT			
DRAWN: M.RUDKIN			
CUSTOMER REF.:			
ASSEMBLY DRG:			

PART No.	DIM 'A'	DIM 'B'	DIM 'C'
S03-10100300R	10.0	10.0	3.0
S03-15100300R	15.0	10.0	3.0
S03-30100300R	30.0	10.0	3.0

HARWIN

www.harwin.com
technical@harwin.com

THIS DRAWING AND ANY INFORMATION OR DESCRIPTIVE MATTER SET OUT HEREON ARE CONFIDENTIAL AND COPYRIGHT PROPERTY OF THE HARWIN GROUP AND MUST NOT BE DISCLOSED, LOANED, COPIED OR USED FOR MANUFACTURING, TENDERING OR FOR ANY OTHER PURPOSE WITHOUT THEIR WRITTEN PERMISSION.

TOLERANCES

X. = ±1mm
X.X = ±0.50mm
X.XX = ±0.20mm
X.XXX = ±0.01mm

ANGLES = ±5°

UNLESS STATED

MATERIAL:

NICKEL SILVER, HALF
HARD NS106, TO BS1653
0.15mm THICK

FINISH: SEE ABOVE

S/AREA:

mm²

TITLE:

EMC-BOARDWARE
SHIELD CAN

DRAWING NUMBER:

S03-XXXXXXXOR

SHT
3 OF
4

Customer Information Sheet

DRAWING No.: S03-XXXXXXXOR

IF IN DOUBT - ASK

©

NOT TO SCALE

THIRD ANGLE PROJECTION

ALL DIMENSIONS IN mm

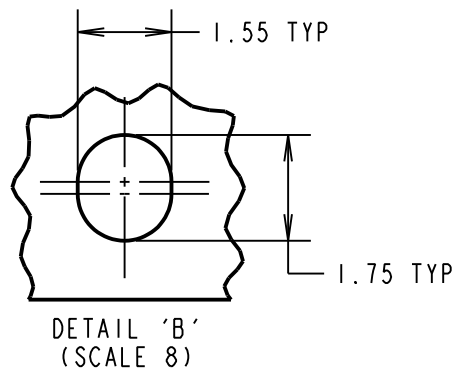
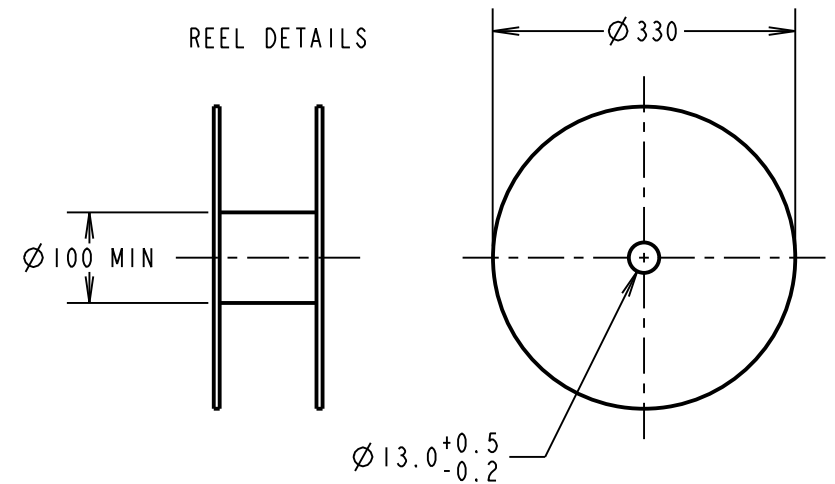
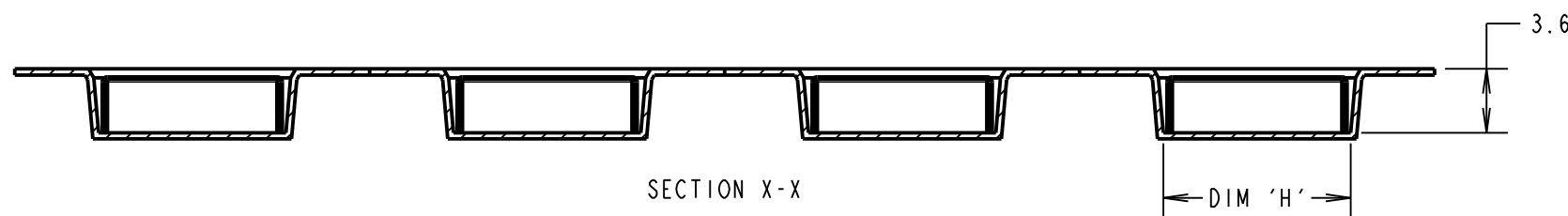
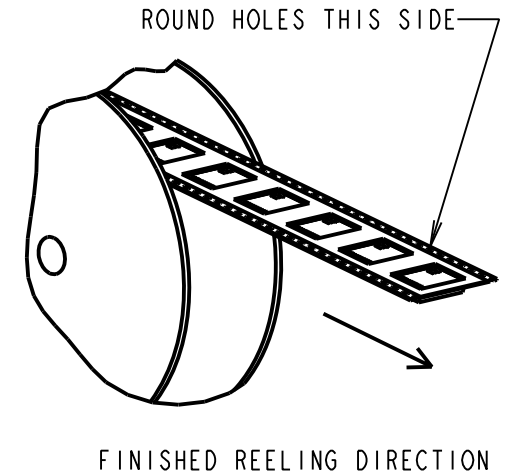
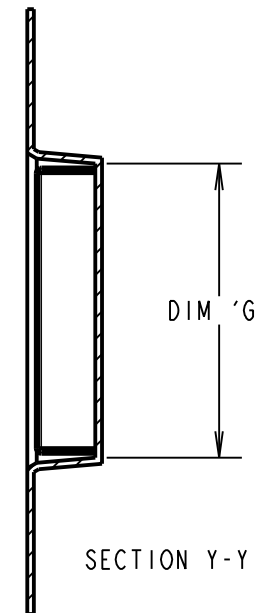
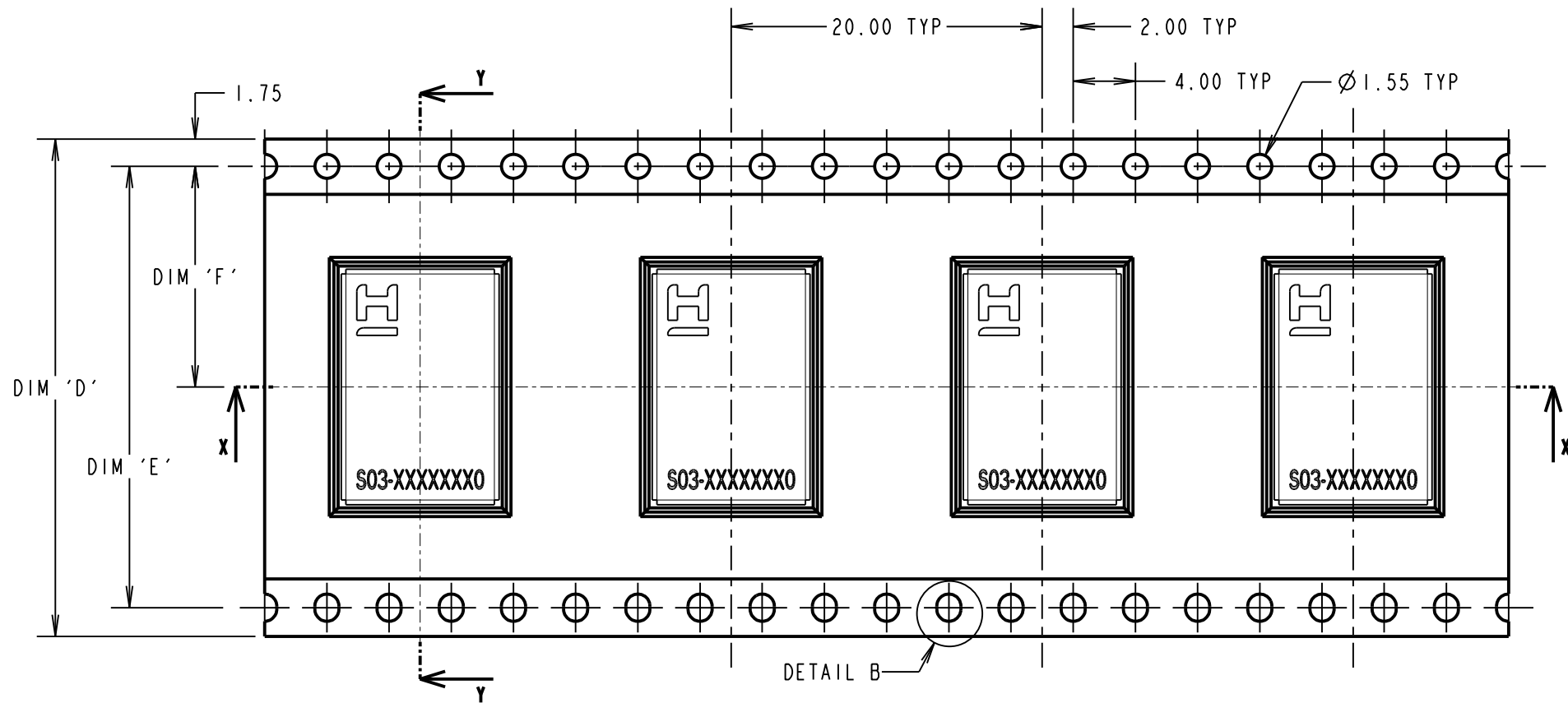

ORDER CODE:

S03-XXXXXXXOR

SIZE:

DIM 'A' = LENGTH
 DIM 'B' = WIDTH
 DIM 'C' = HEIGHT

FINISH:

0 = UNPLATED FINISH

PACKING:

R = TAPE AND REEL (SEE NOTE 1)

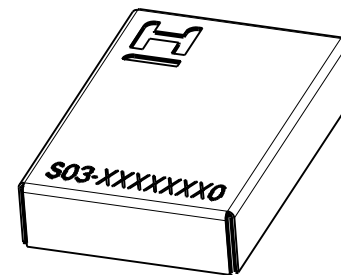

PART No.	DIM 'D'	DIM 'E'	DIM 'F'	DIM 'G'	DIM 'H'
S03-10100300R	32.00±0.30	28.40	14.20	10.55	10.55
S03-15100300R	32.00±0.30	28.40	14.20	15.55	10.55
S03-30100300R	44.00±0.30	40.40	20.20	30.55	10.55

MR	ISS.	DATE	C/NOTE
4		09.10.19	22118
APPROVED: M.RUDKIN			
CHECKED: S.BENNETT			
DRAWN: M.RUDKIN			
CUSTOMER REF.:			
ASSEMBLY DRG:			

NOTES:

1. QUANTITY OF COMPONENTS PER REEL = 900.
2. PRODUCT IS TAPE AND REELED IN GENERAL ACCORDANCE WITH EIA-481-2 (ELECTRONICS INDUSTRIES ASSOCIATION).

HARWIN

www.harwin.com
 technical@harwin.com

THIS DRAWING AND ANY INFORMATION OR DESCRIPTIVE MATTER SET OUT HEREON ARE CONFIDENTIAL AND COPYRIGHT PROPERTY OF THE HARWIN GROUP AND MUST NOT BE DISCLOSED, LOANED, COPIED OR USED FOR MANUFACTURING, TENDERING OR FOR ANY OTHER PURPOSE WITHOUT THEIR WRITTEN PERMISSION.

TOLERANCES

X. = ±1mm
 X.X = ±0.50mm
 X.XX = ±0.20mm
 X.XXX = ±0.01mm
 ANGLES = ±5°
 UNLESS STATED

MATERIAL:

SEE SHEET 3

FINISH: SEE ABOVE

S/AREA:

mm²

TITLE:

EMC-BOARDWARE SHIELD CAN

DRAWING NUMBER:

S03-XXXXXXXOR

SHT 4 OF 4