

SF2229A

**70 MHz
SAW Filter**

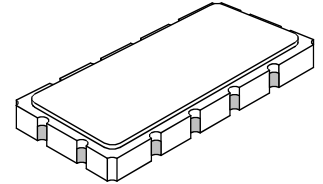

SM13365-12

- *Precision IF SAW Filter*
- *Hermetic 13.3 x 6.5 mm Surface-mount Case*
- *Complies with Directive 2002/95/EC (RoHS)*
- *Moisture Sensitivity Level: 1*

Absolute Maximum Ratings

Rating	Value	Units
Maximum Incident Power in Passband	+20	dBm
Maximum DC Voltage on any Non-ground Terminal	10	VDC
Storage Temperature Range of Component	-55 to +95	°C
Storage Temperature Range in Tape and Reel	-40 to +85	°C
Suitable for Lead-free Soldering - Maximum Soldering Profile	260 °C for 30 s	

Electrical Characteristics

Characteristic	Sym	Notes	Min	Typ	Max	Units
Center Frequency	f_C		69.9	70.0	70.1	MHz
1 dB Bandwidth	BW_1		0.8	0.92		
3 dB Bandwidth	BW_3		1.1	1.2		
40 dB Bandwidth	BW_{40}			2.2	2.3	
Insertion Loss	IL			10.5	12.0	dB
Amplitude Ripple, $f_C \pm 0.3$ MHz				0.7	1.2	dB _{p-p}
Group Delay Ripple, $f_C \pm 0.3$ MHz				350	400	ns _{p-p}
Relative Attenuation:						dB
10 to 65 MHz			45	55		
75 to 200 MHz			45	55		
Operating Temperature Range			-55		+95	°C
Frequency Temperature Coefficient				-94		ppm/°C

Impedance Matching to 50 Ω Unbalanced Source/Load	External L-C
Case Style	SM13365-12 13.3 x 6.5 mm Nominal Footprint
Lid Symbolization (YY = year, WW = week, S = shift, ## =Sequence Code)	RFM, SF2229A, YYWWS##



CAUTION: Electrostatic Sensitive Device. Observe precautions for handling.

NOTES:

1. The design, manufacturing process, and specifications of this device are subject to change.
2. US or International patents may apply.
3. RoHS compliant from the first date of manufacture.

Filter Amplitude Response Plots

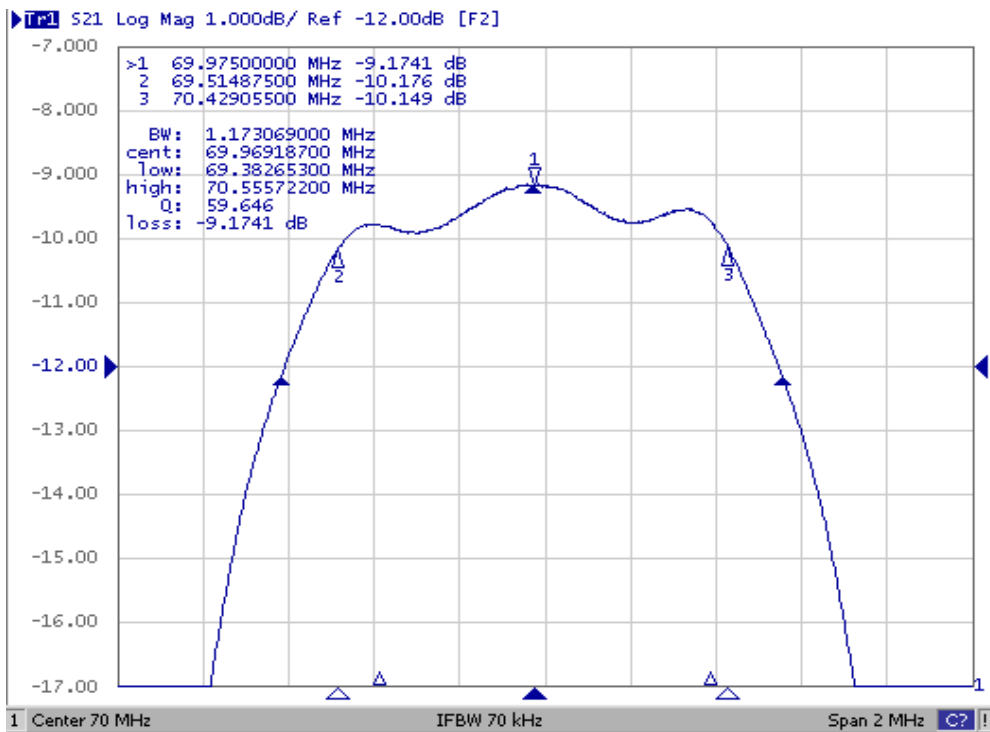
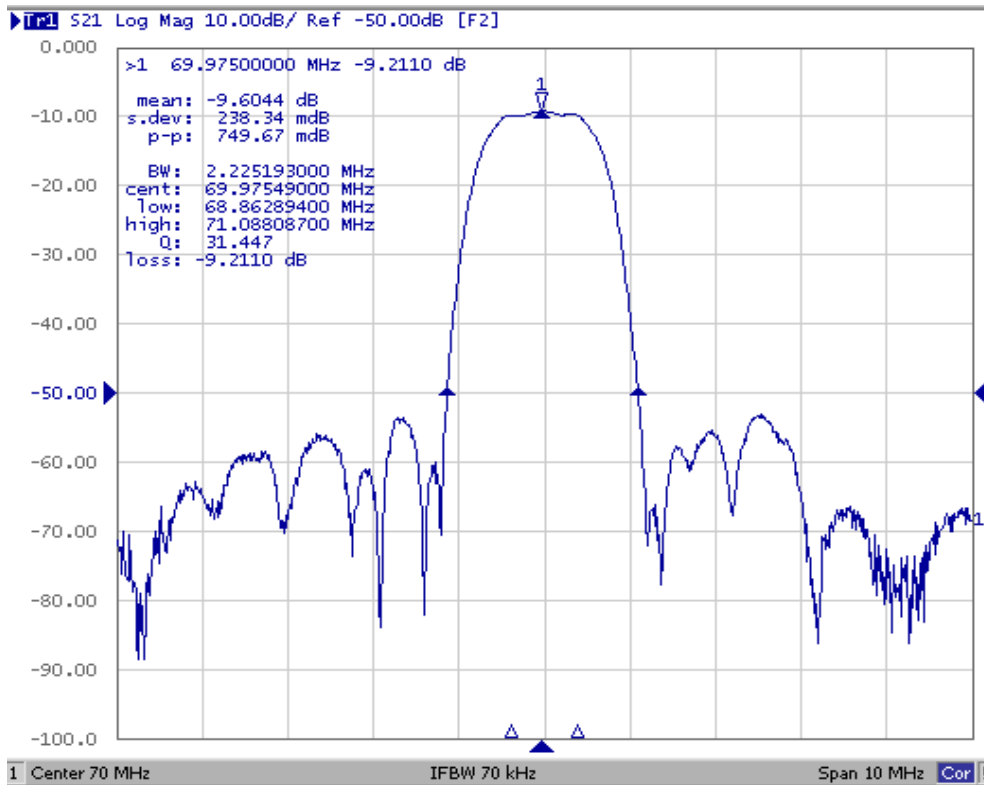

Filter Group Delay Plot

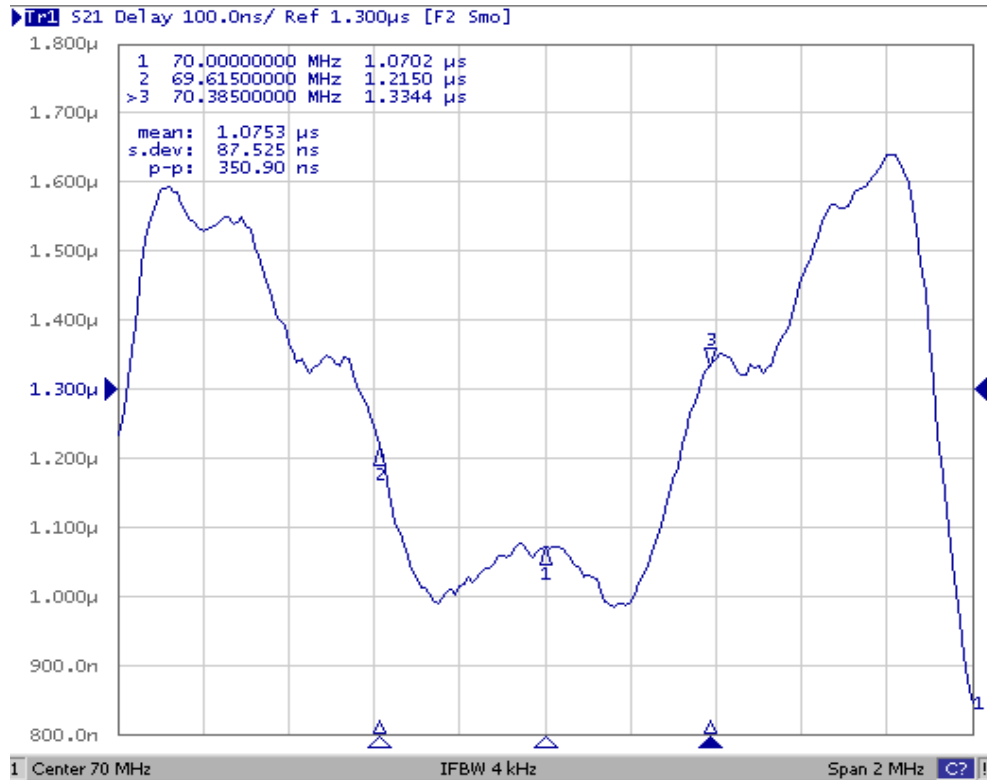

Tuning Component Values

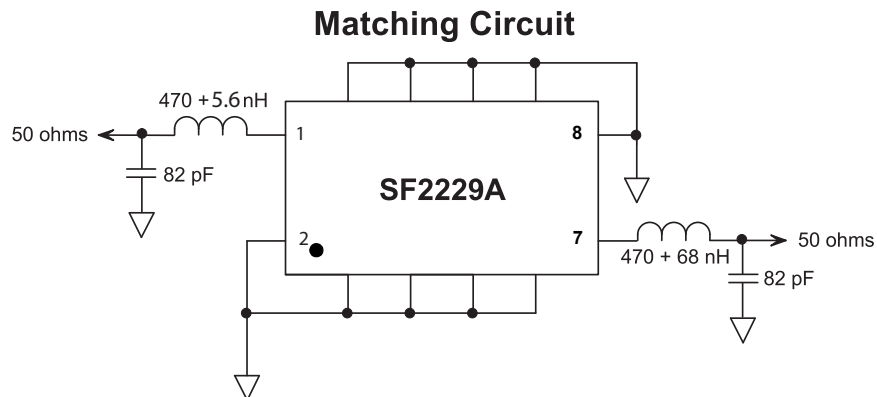

PCB Pad Layout

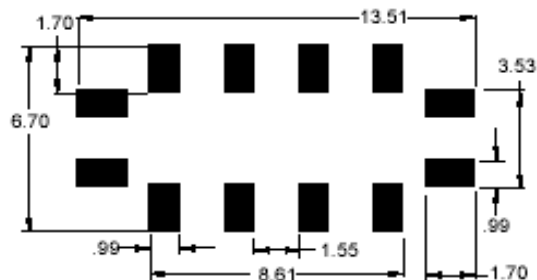

SM13365-12 Ceramic Surface-mount 12-Terminal Case

13.3 x 6.5 mm Nominal Footprint

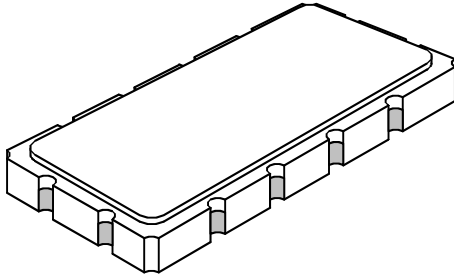

Case Dimensions

Dimension	mm			Inches		
	Min	Nom	Max	Min	Nom	Max
A	13.10	13.30	13.50	0.516	0.524	0.531
B	6.30	6.50	6.70	0.248	0.256	0.264
C			1.80			0.071
D		1.50			0.059	
E		0.80			0.031	
H		0.80			0.031	
P		2.54			0.100	

Electrical Connections

Connection	Terminals
Input	1
Input Ground	2
Output	7
Output Ground	8
Case Ground	3, 4, 5, 6, 9, 10, 11, 12

Case Material

Materials	
Solder Pad Plating	0.3 to 1.0 μm Gold over 1.27 to 8.89 μm Nickel
Lid Plating	2.0 to 3.0 μm Nickel
Body	Al_2O_3 Ceramic

Case Outline Drawing

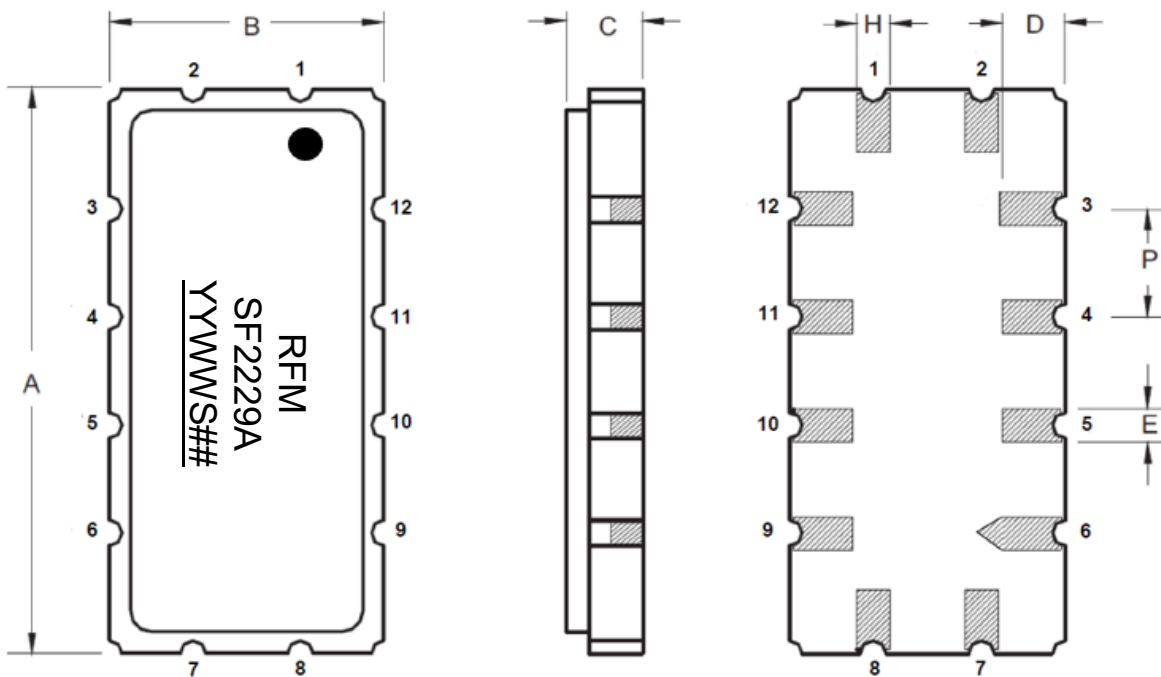

Tape and Reel Specifications

Tape and Reel Standard per ANSI/EIA-481

Reel Count:

7" = 500

13" = 1000

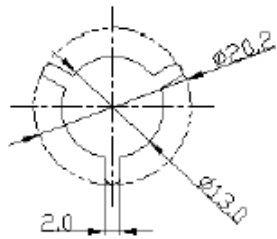
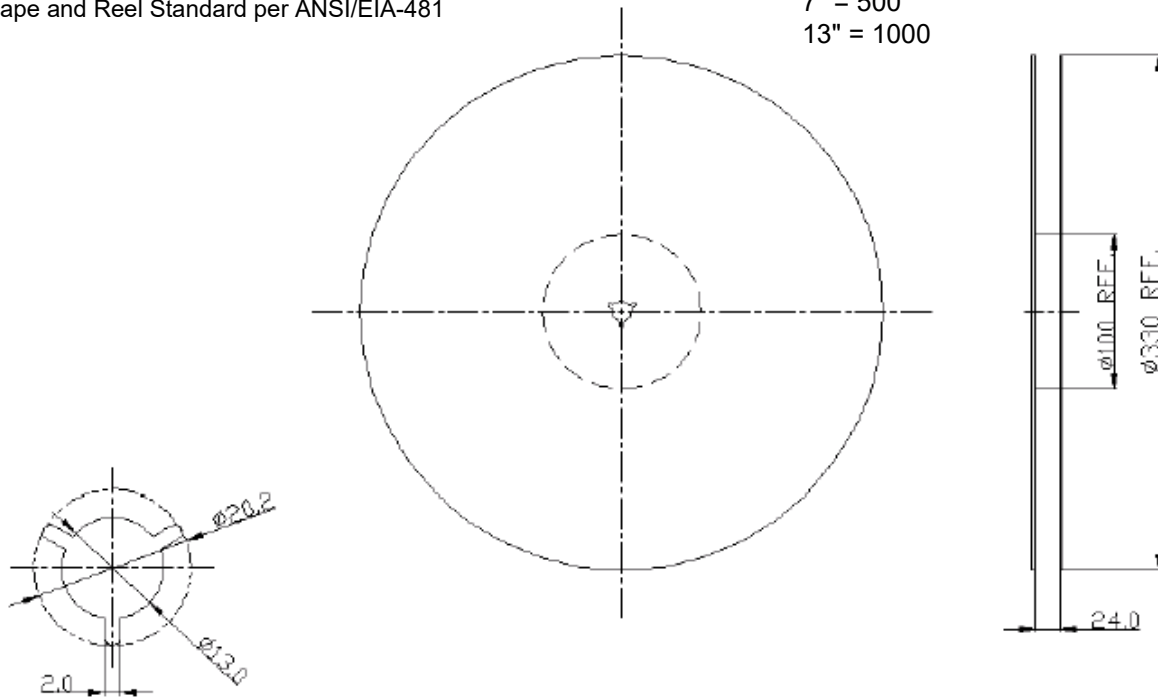

13.3X6.5

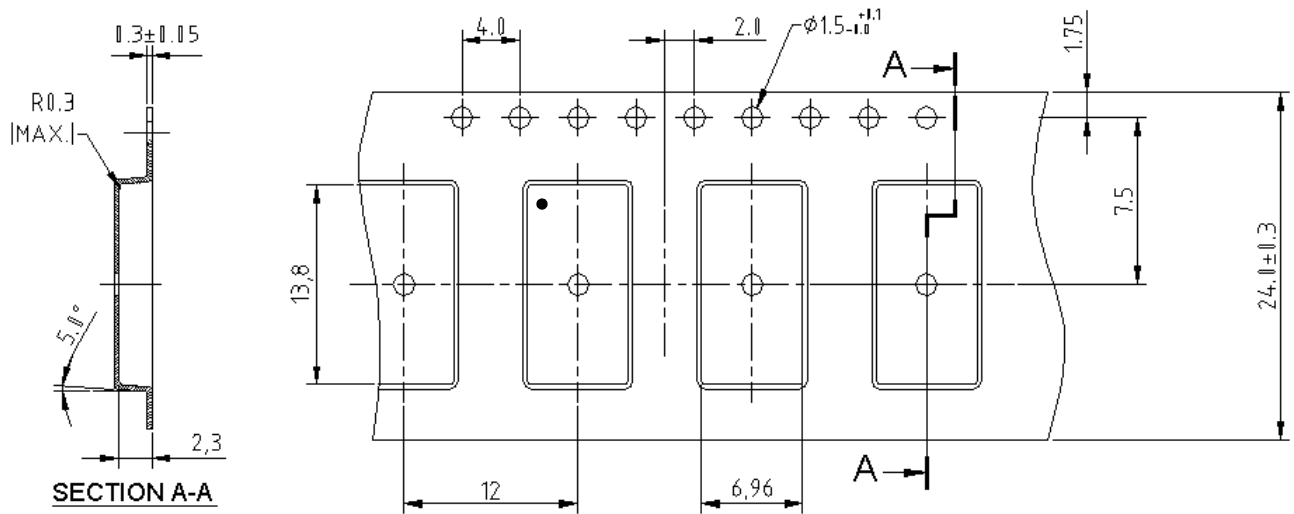

Recommended Reflow Profile

1. Preheating shall be fixed at 150~180°C for 60~90 seconds.
2. Ascending time to preheating temperature 150°C shall be 30 seconds min.
3. Heating shall be fixed at 220°C for 50~80 seconds and at 260°C +0/-5°C peak (10 seconds).
4. Time: 5 times maximum.

