

S12-DHS1-5KSA5

Dual Output Hall Switch Sensor

- Dual output hall switch
- 55 gauss operate
- NPN w/5k pull up resistor
- Stainless 12x1mm x 35mm housing
- Shielded 4 wire 22 AWG 80°C PVC, 5ft



CUSTOMER FOCUSED ENGINEERING + MODULAR DESIGN

Part Description: **S12-DHS1-5KSA5**

Housing	Sensor Type & Function	Electrical Option	Connection Type
S = Stainless Steel, Thread Pitch M12x1, 35mm Long	Dual Output Hall Switch Sensor	NPN, 5k Pull Up Resistor	SA Shielded 4 Wire 22 AWG 80°C PVC

Modify, update, or enhance any sensor with our modular features and functionality.

HOUSING - Aluminum, stainless steel, plastic, threaded, flange mount, customer specific

ELECTRICAL - Every sensor function available in various electrical options (NPN, PNP, TTL, etc.)

CONNECTION - Deutsch, Amphenol, many other brands, free end wires, pigtails, any length

Need a Custom Sensor Solution?... Send us your application specific requirements at sensorso.com

'Dual Output' Hall Switch Sensor

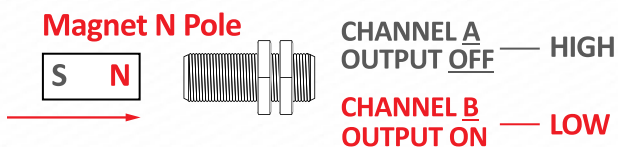
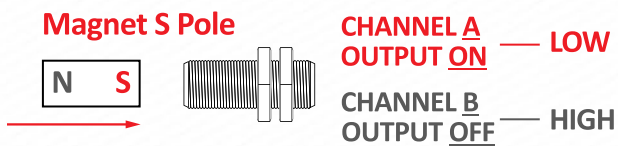

Type - DHS

DESCRIPTION

- Sensor produces dual pulsing outputs, 1 South Pole and 1 North Pole.
- Functions as directional limit switch when magnets are mounted at each end of range of motion.
- No orientation required. Use lock nuts to set air gap within range of target magnets.
- South Pole element is located closer to sensor face and will detect at a slightly greater operate gap.
- Note: Operate and release gaps are dependent on the size, material, grade, and temperature of the target magnet.

FEATURES

- Rugged, Sealed Housing
- Greater Detection Gap Than Standard DHS Sensor
- Solid State (Nothing to wear out!)

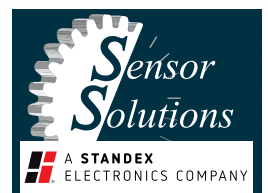

S12-DHS1-5KSA5

Dual Output Hall Switch Sensor

Note: Check our website or contact us to see all of our Options, including more and less sensitive choices.

Electrical Specifications	Conditions	Min	Max	Unit
Temperature Range*	Operating	-40	+110*	Deg C
Supply Voltage, Vcc	Over temperature	+4.5	+28	Volts DC
Supply Current, Output Off	Into Vcc	+4	+14	mA
Frequency Range		0	20	kHz
Internal Pull Up Resistor	Vcc to Vout	4.9	5.1	kOhms
Saturation Voltage Low 100% tested at 20°C before shipping	Vcc=12V, Rload >100k	0	.4	Volts
Saturation Voltage High 100% tested at 20°C before shipping	Vcc=12V, Rload >100k	11.5	12	Volts
Output Rise Time 10-90%	C < 100pF	-	8.0	µS
Output Fall Time 90-10%	C < 100pF	-	2.0	µS
ESD **	Nondestructive	-	8000	Volts
EMI **	20k to 1 G Hz	-	100	V / M

* T max = 150°C is available, contact factory.

** Specifications not available at release.

Rev B

Absolute Max Limits	Min	Max	Unit
Supply Voltage, Vcc	-32	+32	Volts DC
Voltage Applied to Output	-0.3	+28	Volts
Current Into Output	-	25	mA
Current Out of Output	-	Vcc/5k	mA
Load Dump, 40 mS Rs = 20	-	60	Volts

Environmental Specifications

Corrosion Resistance	500 hours salt spray ASTM B-117
Installation Torque	23 Foot-Pounds Maximum
Enclosure	Nema 1,3,4,6,13 & IEC IP67
Vibration	10 G's 2 to 2000 Hz Sinusoidal
Mechanical Shock	100 G's, 11 mS Half-Sine

S12 Housing, 303 Stainless Steel, M12X1, 35mm Long

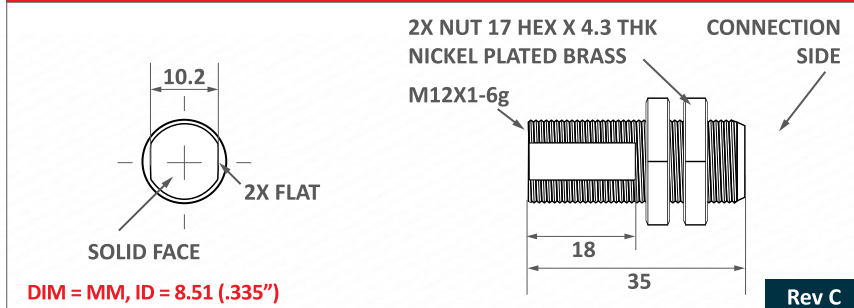

Rev C

Magnetic Characteristics	Min	Typ	Max
Operate Point Over Temp 100% tested at 20°C before shipping	15 G	55 G	76 G
Release Point Over Temp	5 G	35 G	57 G
Hysteresis Over Temp	5 G	20 G	28 G
Inside Depth to N pole Element	-	.060"	-
Inside Depth to S pole Element	-	.090"	-

SA5, Shielded 4 Wire 22 AWG 80°C PVC

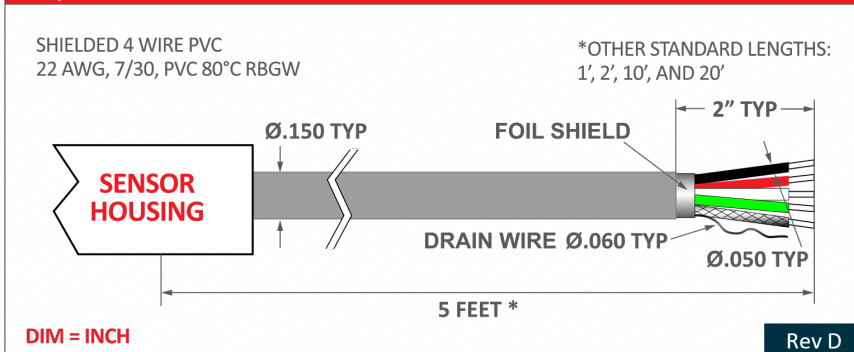

Rev D

Connections Chart

Pin 1 (Red)	Vcc	Pin 3 (White)	S Pole Vout
Pin 2 (Black)	Ground	Pin 4 (Green)	N Pole Vout

S12-DHS

S12-DHS1-5KSA5

Dual Output Hall Switch Sensor

Sensor Function

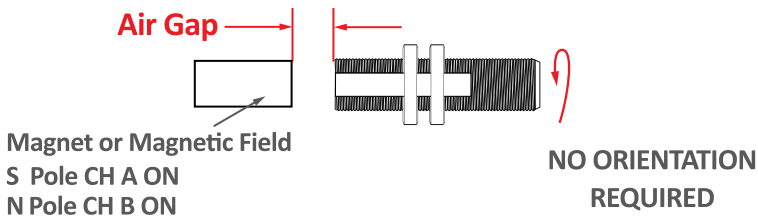

S12-DHS

5K, 5k Pull-up Resistor

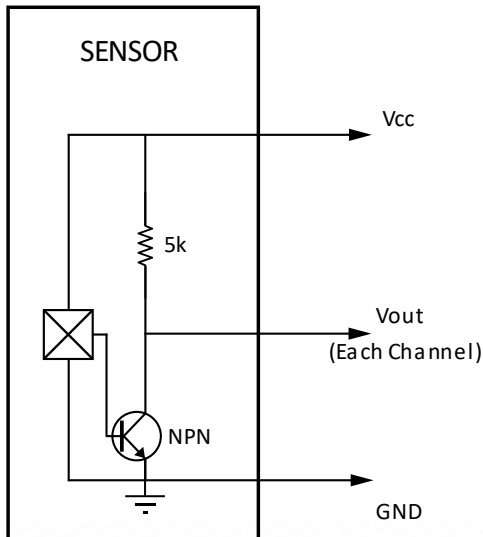

Date Code 'YYM'

YY = YEAR, M = MONTH

A JAN	D APR	H JUL	L OCT
B FEB	E MAY	J AUG	M NOV
C MAR	G JUN	K SEP	N DEC

Marking

DATE CODE, THIS SURFACE

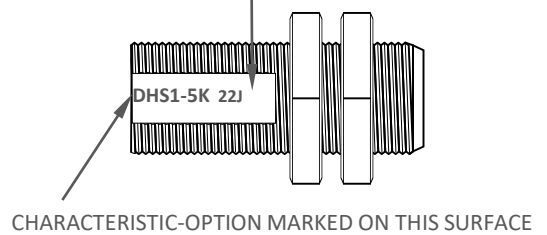

Handling Instructions

**DO NOT CONTACT
FACE TO FACE**

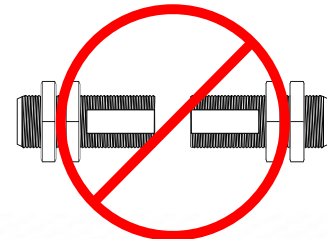

**CONTACT WITH OTHER MAGNETS MAY
REDUCE THE MAXIMUM OPERATING GAP**

Please note: All technical specifications on this series datasheet refer to the standard product range. Modifications in the sense of technical progress are reserved. For general information only. For more specific information, please consult the product datasheet, available upon request.

This series datasheet could contain technical inaccuracies or typographical errors. Changes are periodically made to the information herein. These change will be incorporated in future revisions.

For deviating values, most current specifications and products please contact your nearest sales office.