



TAOGLAS®



Datasheet

Low Profile and High Efficiency 868 MHz ISM Band Loop Antenna

Part No:
ILA.02

Description:

868 MHz ISM Band Loop Antenna

Features:

Small size antenna, low profile, and high efficiency
868 MHz ISM Band
1 dBi Peak Gain
10 x 3.2 x 0.5 mm size
SMT Compatible
RoHS & REACH Compliant

1.	Introduction	3
2.	Specifications	4
3.	Antenna Characteristics	5
4.	Radiation Patterns	8
5.	Mechanical Drawing – Antenna	10
6.	Mechanical Drawing – Evaluation Board	11
7.	Antenna Integration Guide	12
8.	Soldering Conditions	20
9.	Packaging	21
<hr/>		
	Changelog	23
<hr/>		

Taoglas makes no warranties based on the accuracy or completeness of the contents of this document and reserves the right to make changes to specifications and product descriptions at any time without notice. Taoglas reserves all rights to this document and the information contained herein. Reproduction, use or disclosure to third parties without express permission is strictly prohibited.



1. Introduction



The ILA.02 is a 868 MHz ISM band antenna featuring an excellent efficiency of 60% across the band. This antenna works the best when placed at the center of the board edge. The antenna, at 10 x 3.2 x 0.5 mm, is low profile and would be suitable for devices with space constraints. The ILA.02 is delivered on tape and reel and now allows M2M customers to use an omni-directional SMT antenna. The omni-directional radiation characteristics allow for excellent performance regardless of device orientation. This is especially useful for devices that are not fixed in one particular spot during use. When there is little PCB space available for antenna placement, but high performance is required, the ILA.02 is the ideal choice.

This antenna can be mounted with no performance degradation in either orientation as long as the antenna is soldered correctly via Surface mounting. Please see the integration instructions section for further detail regarding the optimum way to integrate this antenna into your device.

For further optimization to customer-specific device environments and for support to integrate and test this antenna's performance in your device, contact your regional Taoglas Customer Services Team.

Applications:

Automated Meter Reading (AMR)

Radio Frequency Identification (RFID)

Remote Monitoring

Healthcare

Sensing

868 MHz Applications

2. Specifications

Antenna	
Frequency (MHz)	868-870 MHz (ISM)
Efficiency (%)	
80 x 40 mm Ground Plane	55 (typical)
Average Gain (dB)	
80 x 40 mm Ground Plane	-2.5 dB
Peak Gain (dBi)	
80 x 40 mm Ground Plane	1 dBi
Max Return Loss (dB)	-37 dB
VSWR	2:1
Impedance (Ω)	50 Ω
Polarization	Linear
Radiation Pattern	Omni
Input Power(W)	5
Mechanical	
Dimensions (mm)	10 x 3.2 x 0.5
Required Space (mm)	11 x 10.4
Material	Ceramic
EVB Connector	SMA(F)
Environmental	
Temperature Range	-40°C to 85°C
Storage Temperature	-40°C to 105°C
Humidity	40% to 95%
Moisture Sensitivity Level	3 (168 Hours)

3. Antenna Characteristics

3.1 Return Loss

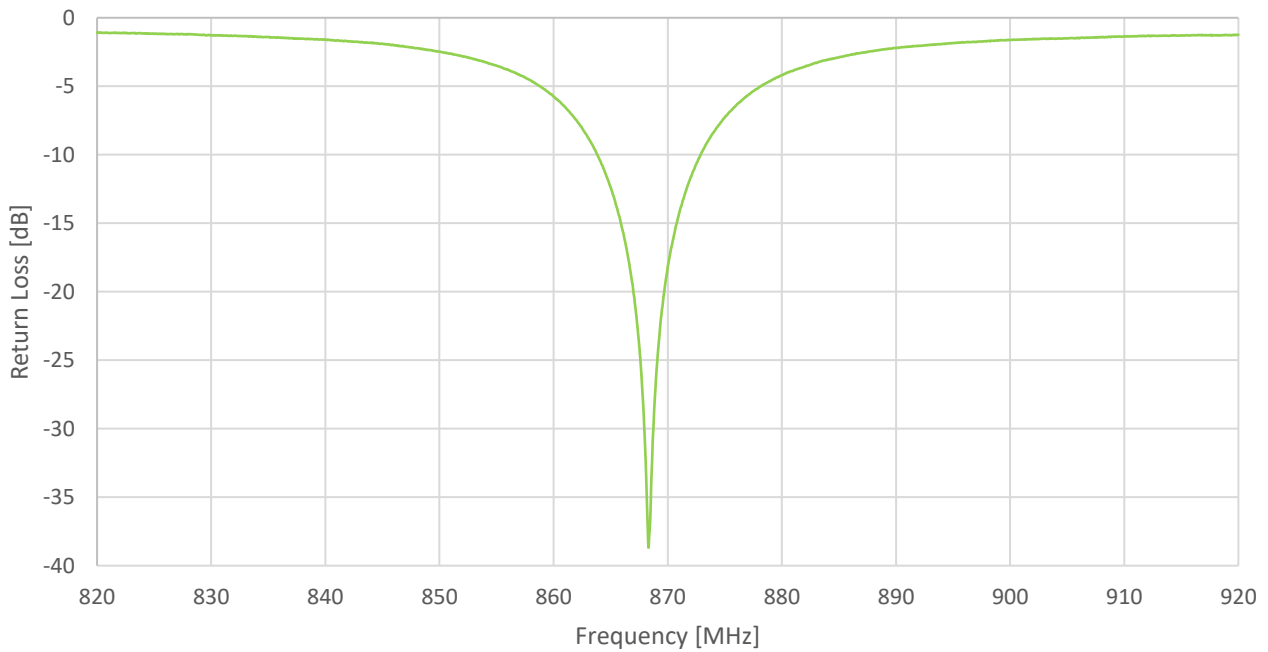

3.2 Efficiency

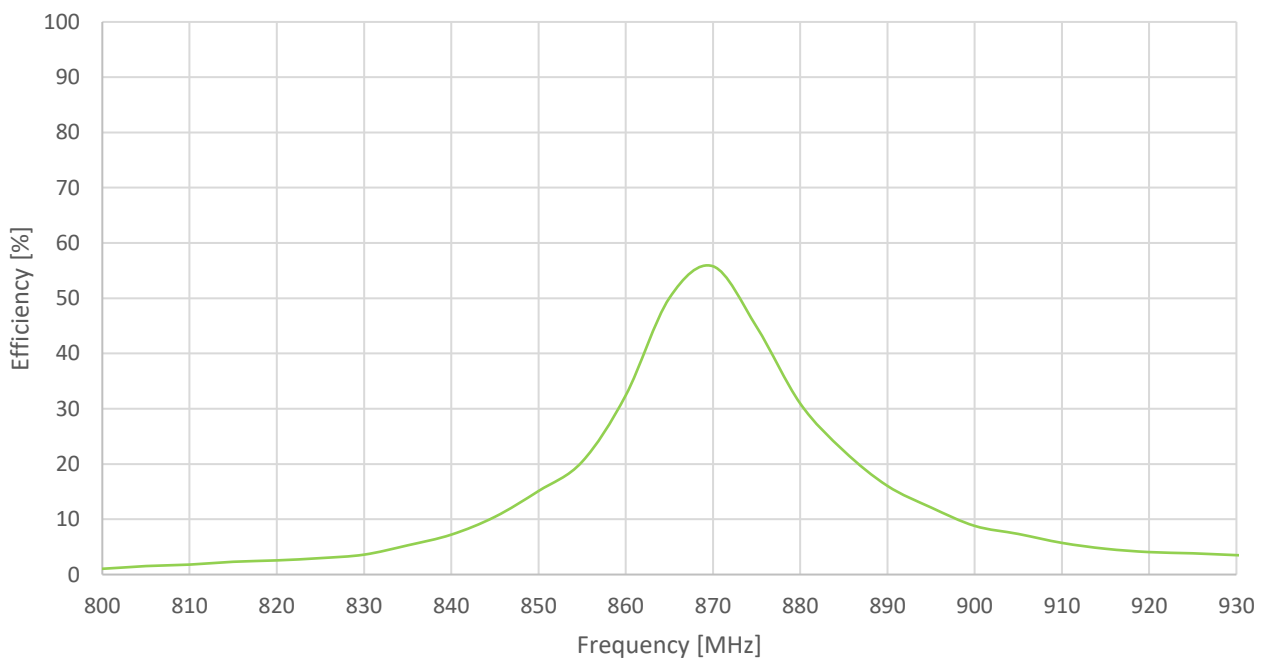

3.3 Average Gain

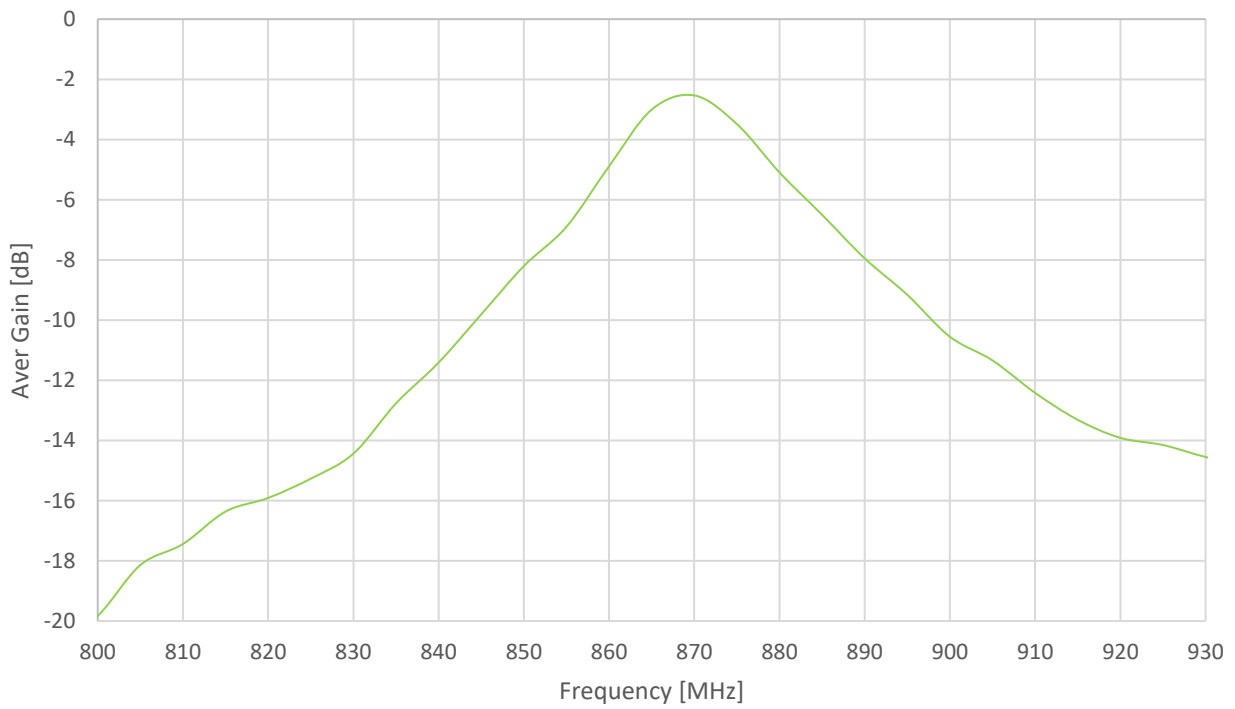

3.4 Peak Gain

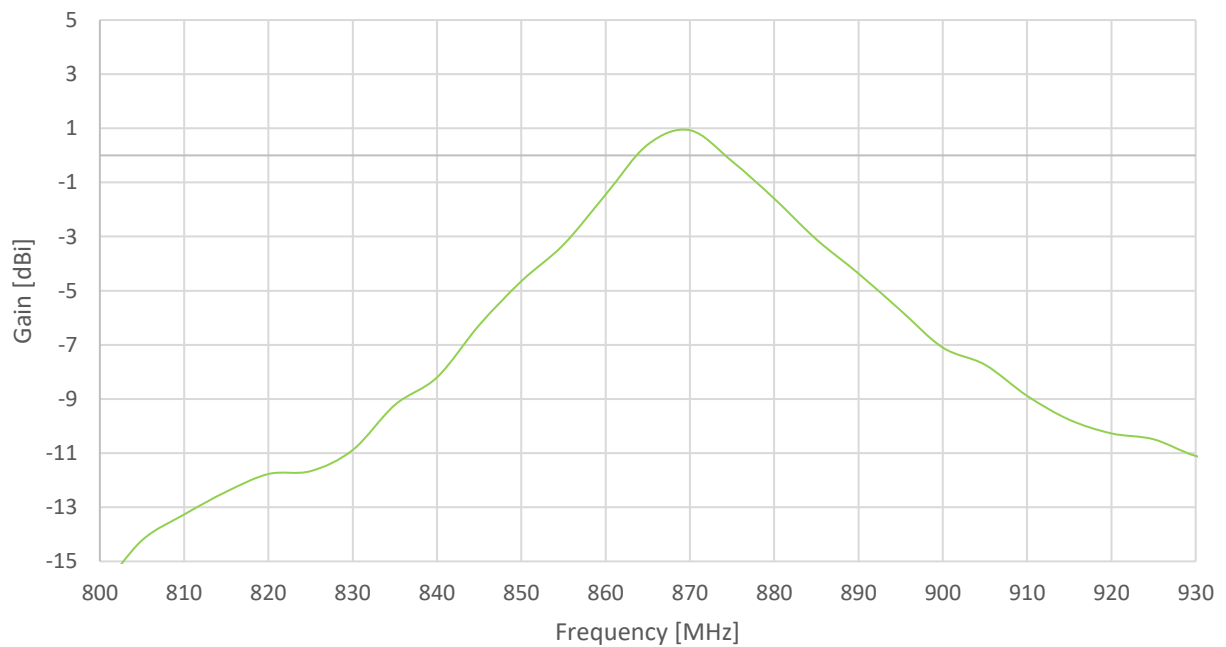

3.5 VSWR

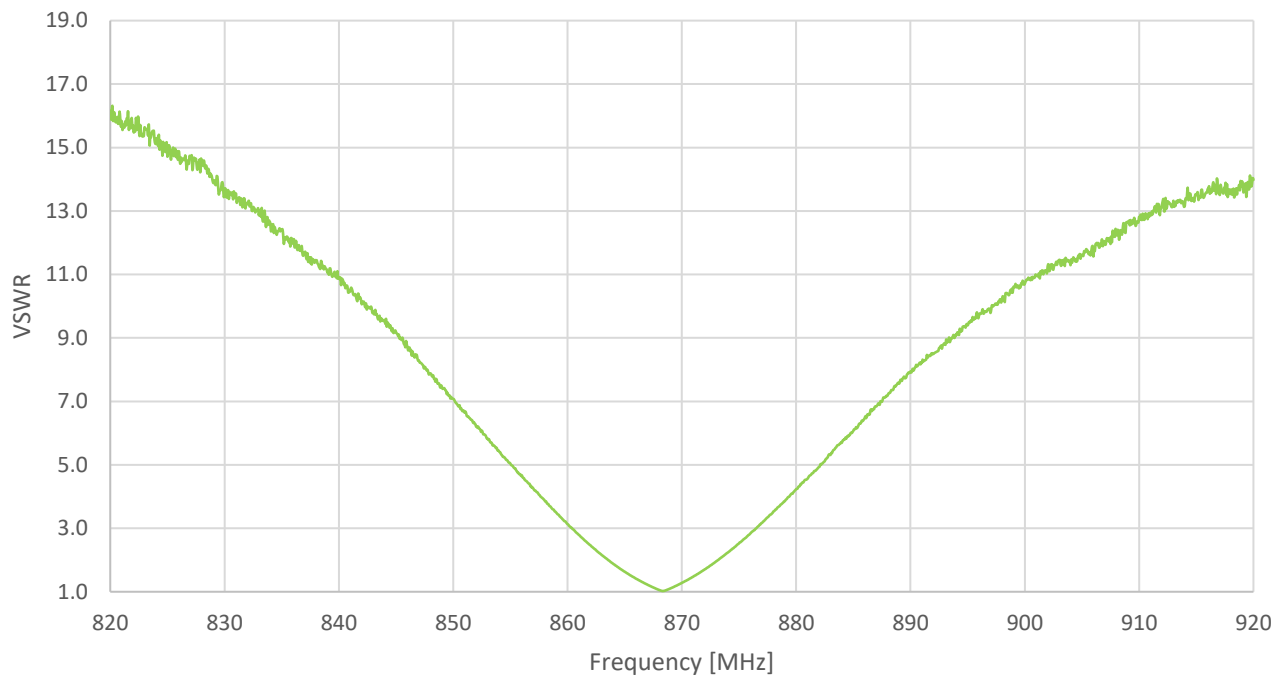

4. Radiation Patterns

4.1 Test Setup – Antenna on Evaluation Board

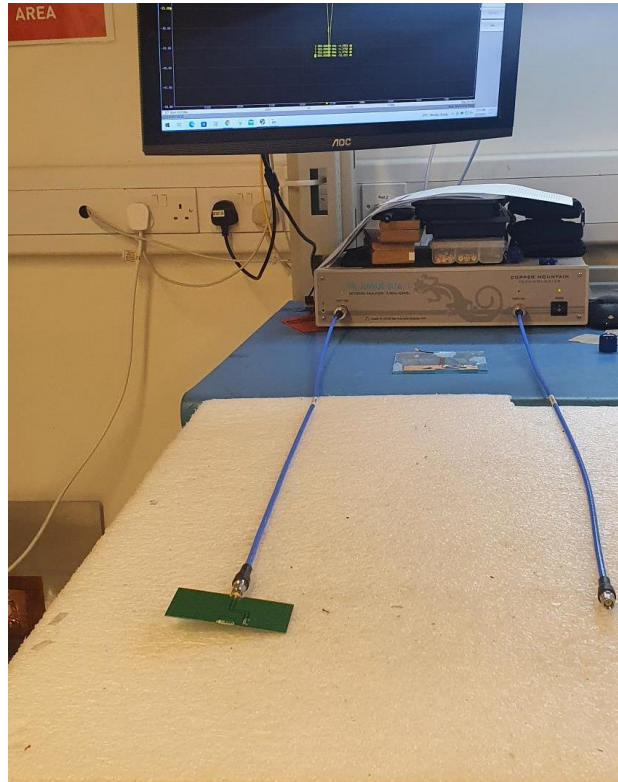

4.3 2D&3D Radiation Pattern

868MHz

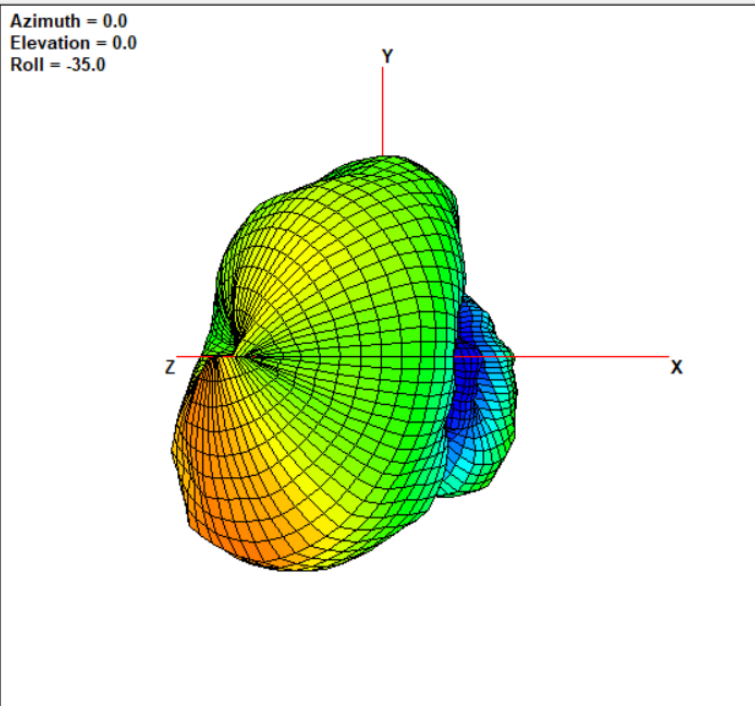

XY Plane

XZ Plane

YZ Plane

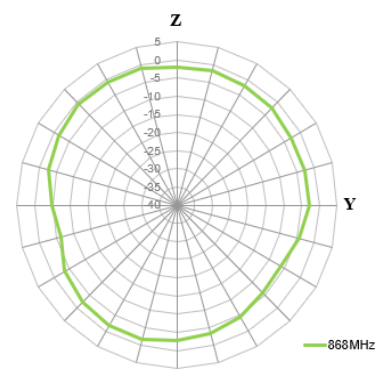
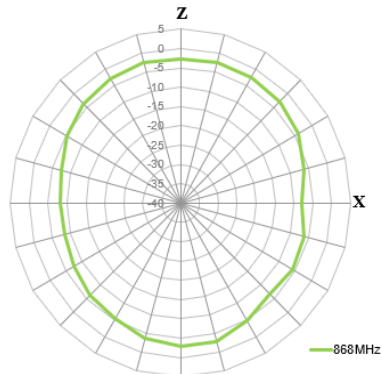
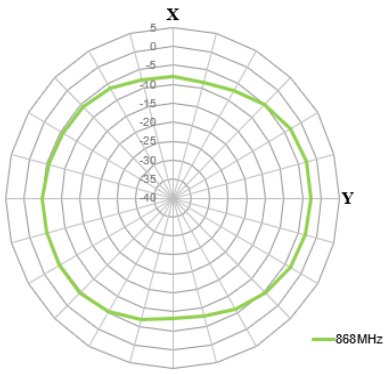

5. Mechanical Drawing – Antenna

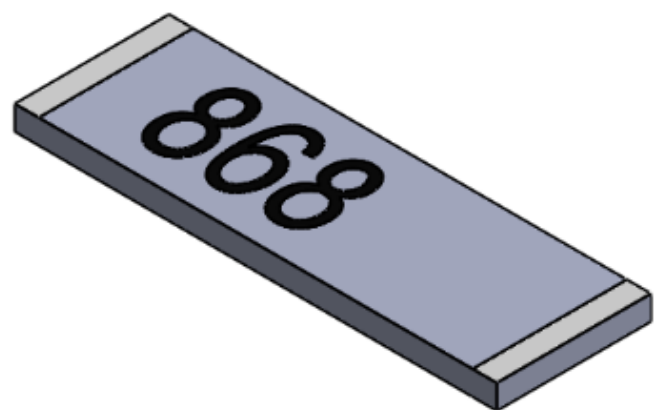
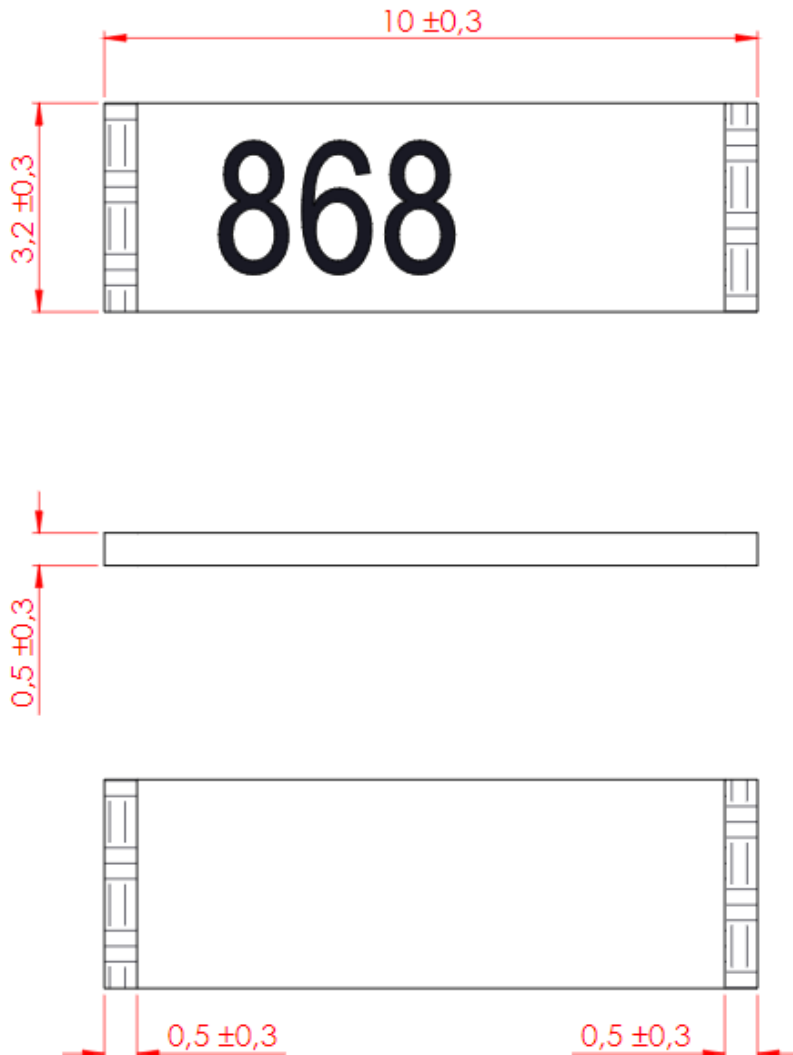

MODEL VIEW

6. Mechanical Drawing – Evaluation Board

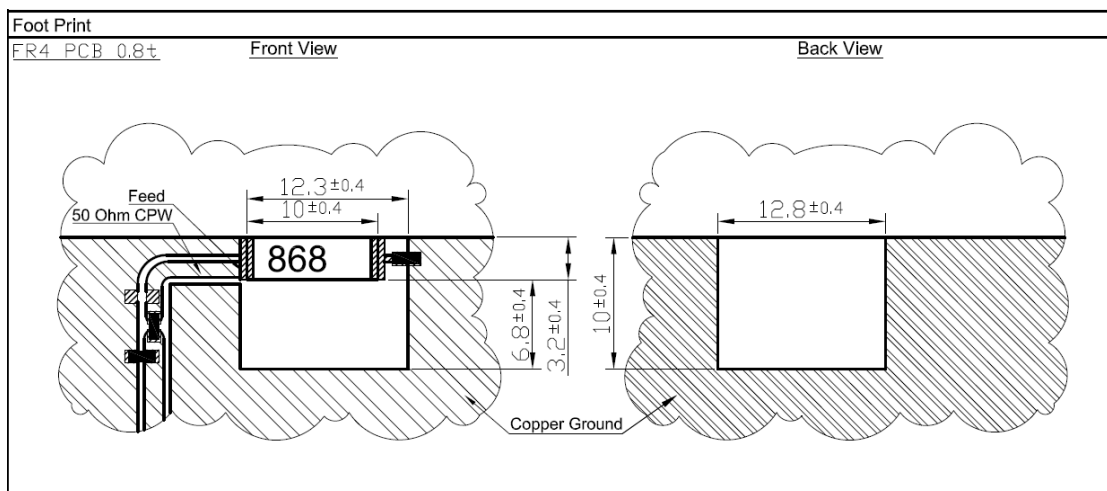
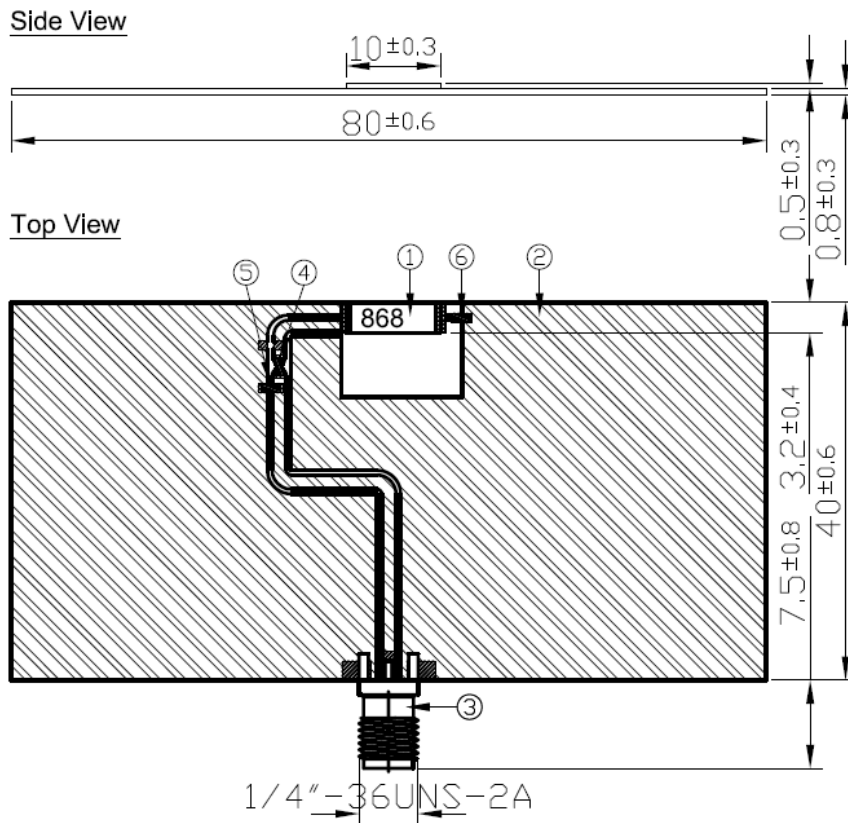

NOTES:

1. Solder Area
2. Logo & Text Ink Printing : Black
3. Copper
4. Matching Component
5. Component 6 is the tuning element of this antenna.

	Name	P/N	Material	Finish	QTY
1	ILA.02 Antenna	001513C000012A	Ceramic	N/A	1
2	ILA EVB Board	100213F000012A	FR4 0.8t	Green	1
3	SMA(F) ST	200413F000012A	Brass	Gold	1
4	Resistor 0Ω (0402)	001511J010012A	Ceramic	N/A	1
5	Capacitor 5pF (0402)	001514F030012A	Ceramic	N/A	1
6	Capacitor 15pF (0402)	001514F040012A	Ceramic	N/A	1

7. Antenna Intergration Guide

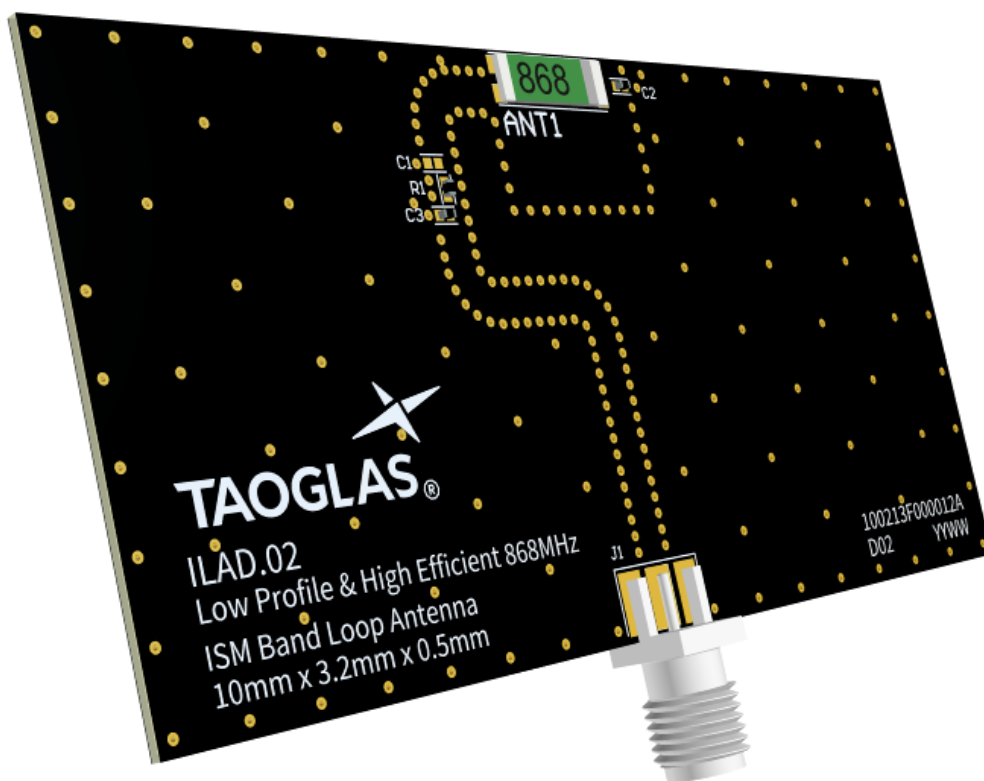

7.1 Schematic Symbol and Pin Definition

The circuit symbol for the antenna is shown below. The antenna has 3 pins with only three pins as functional.

Pin	Description
1	RF Feed
2	Ground
3	FTE

ILA.02
ANT1

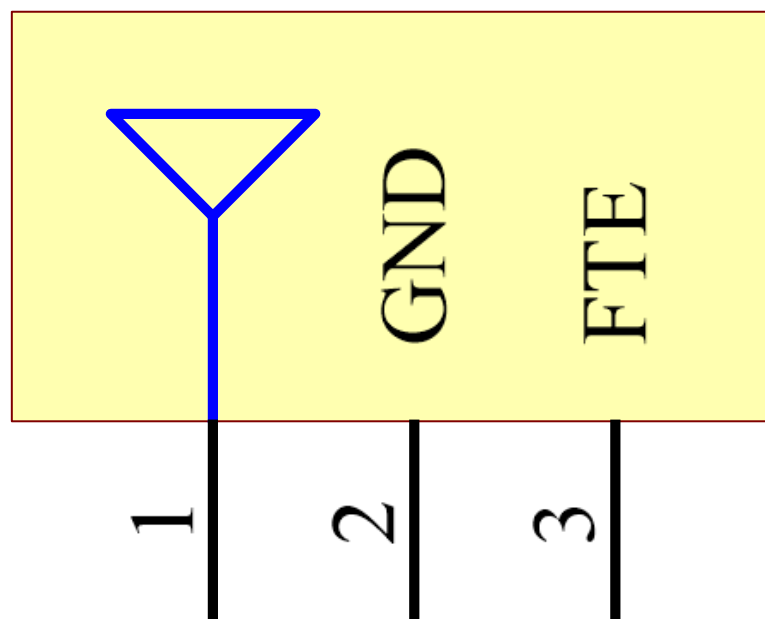

7.2 Antenna Integration

Whatever the size of the PCB, the antenna should ideally be placed on the PCB's longest side, to take advantage of the ground plane. Optimized matching components can be placed as shown.

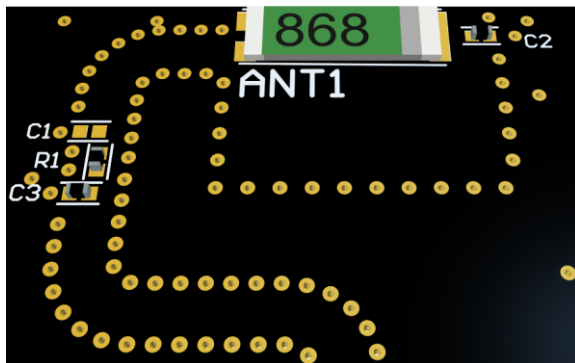

7.3 PCB Layout

The footprint and clearance on the PCB must meet the antenna specification. An example of the PCB layout shows the antenna footprint with clearance. Note the placement of the component C2. C2 is connected to Pin 3 of the antenna and helps with fine-tuning of the antenna. Further, note the placement of the additional components C1, R1, C3. These form a pi-matching network to help with matching the antenna in its final environment.

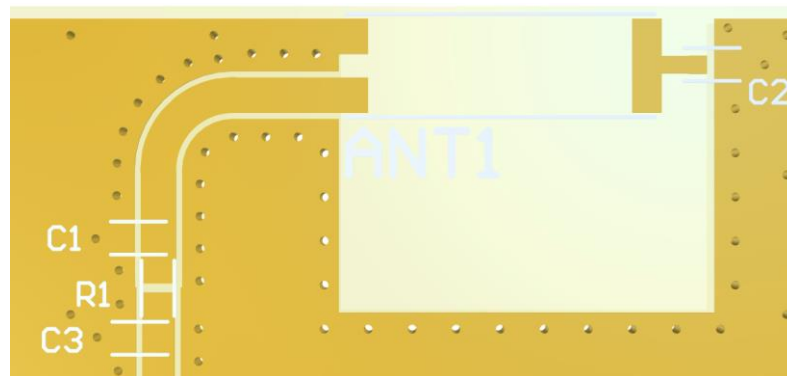

Topside

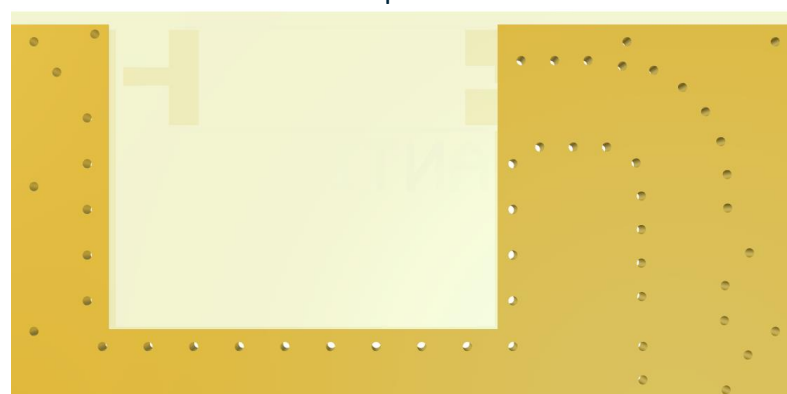

Bottom Side

7.4 PCB Clearance

Below shows the antenna footprint and clearance through ALL layers on the PCB. Only the antenna pads and connections to feed and GND are present within this clearance area (marked RED). The clearance area extends to 10mm in length & 12.8mm in width. This clearance area includes the bottom side and ALL internal layers on the PCB.

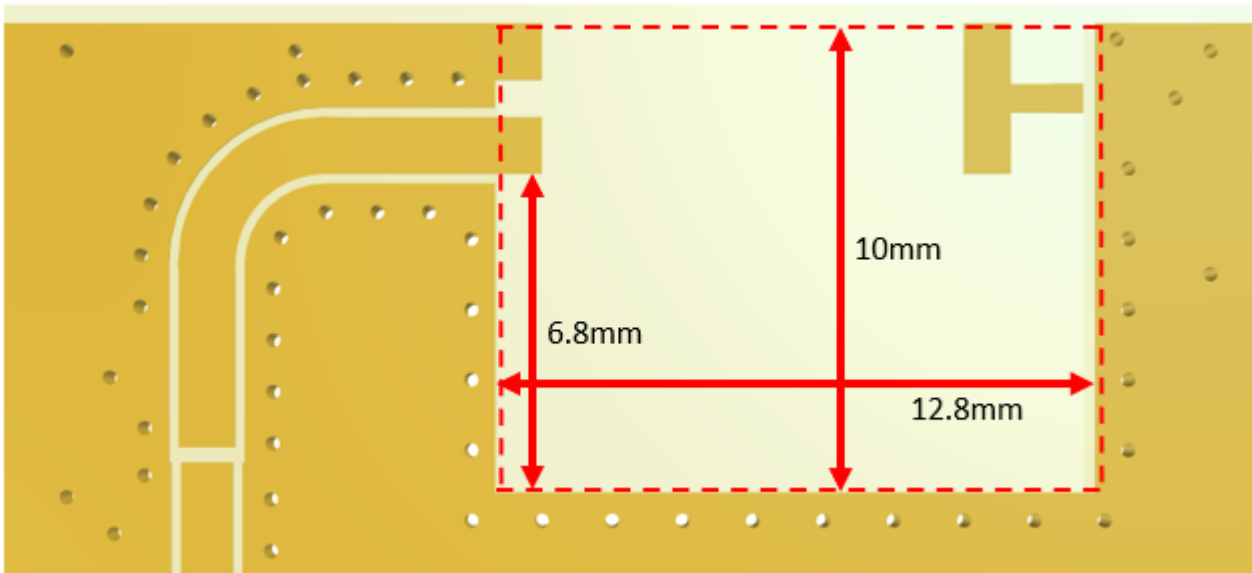

Topside

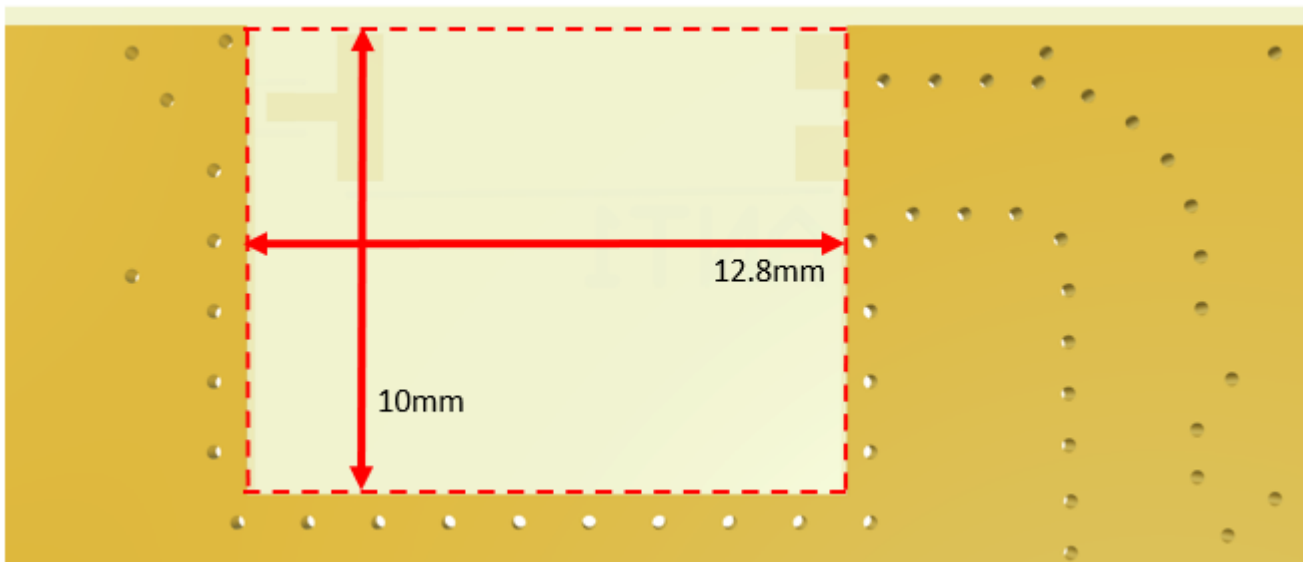

Bottom Side

7.5 Evaluation Board

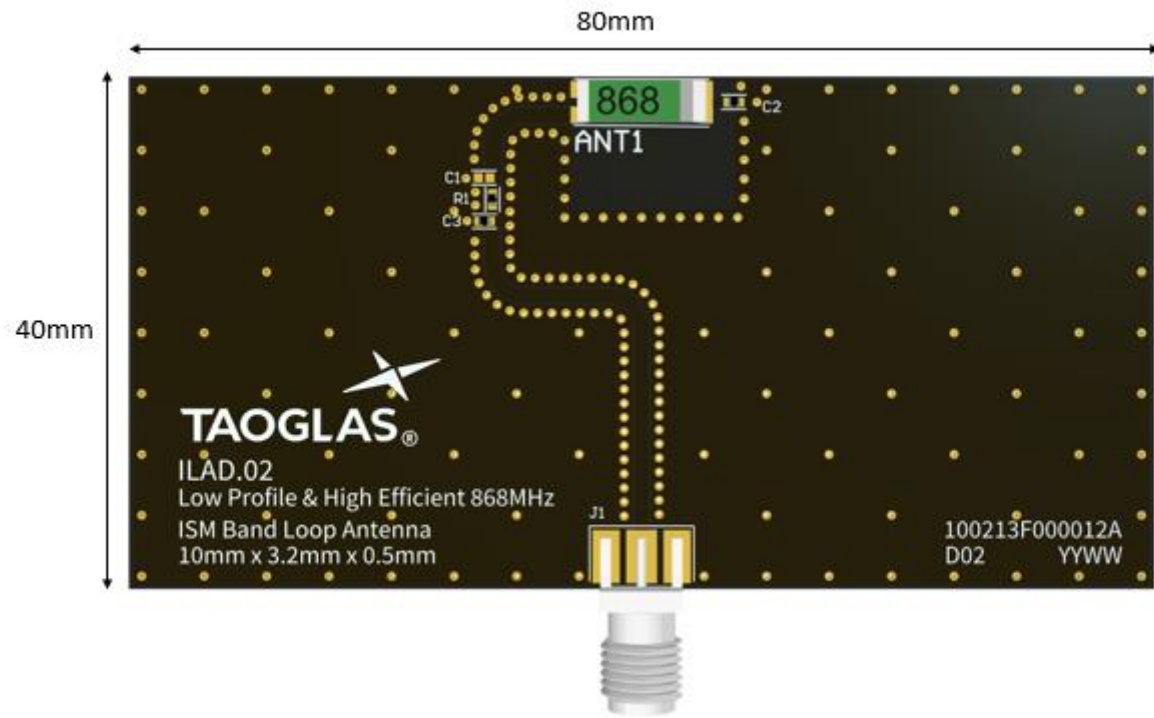

Topside

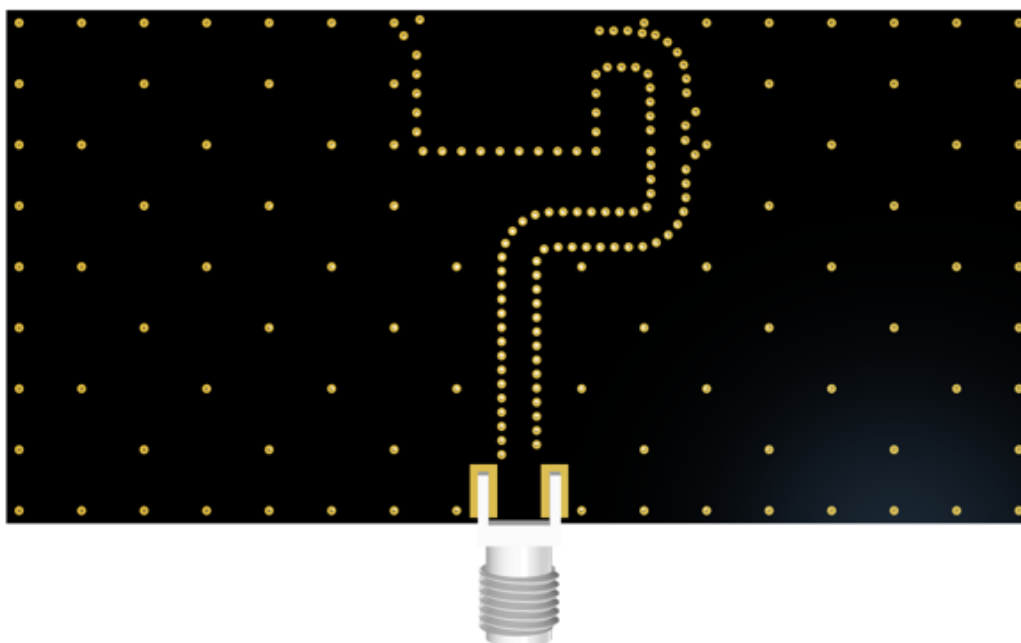

Bottom Side

7.6 Evaluation Board Ground Plane Length

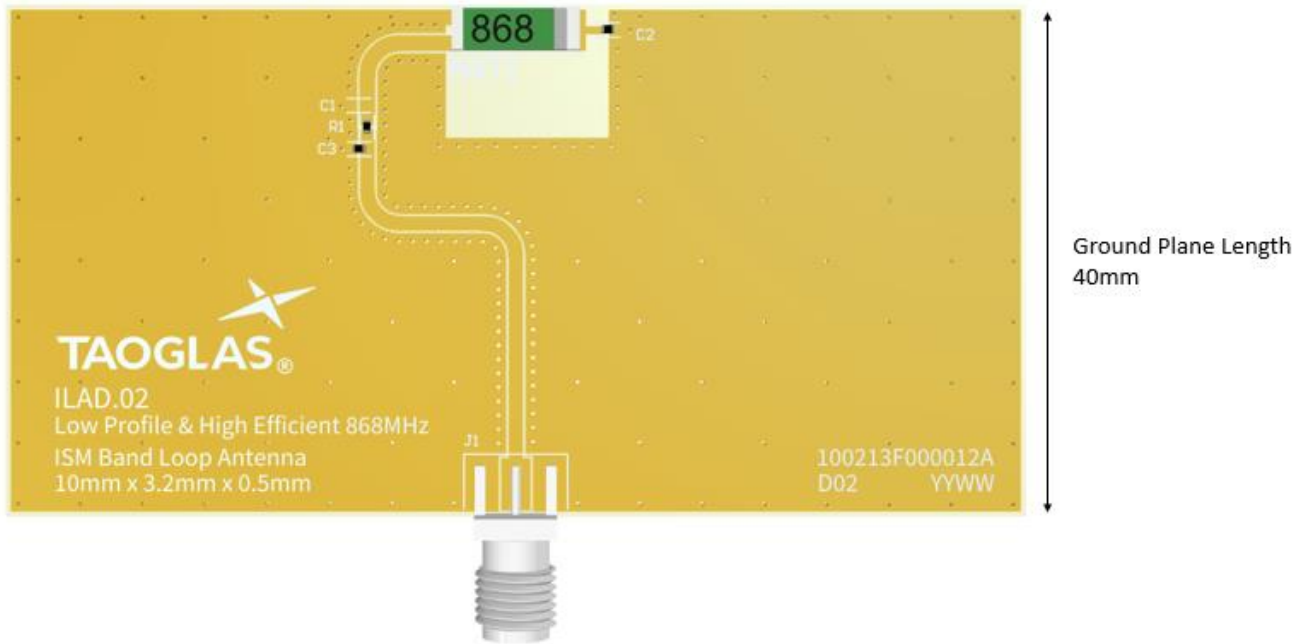

7.7 Evaluation Board Matching Circuit

Matching components for the ILA.02 are required for the antenna to have optimal performance on the evaluation board, located outside of the copper clearance in the space specified in the above images. Additional matching components may be necessary for your device, so we recommend incorporating extra component footprints, forming a “pi” network, between the radio module and the antenna.

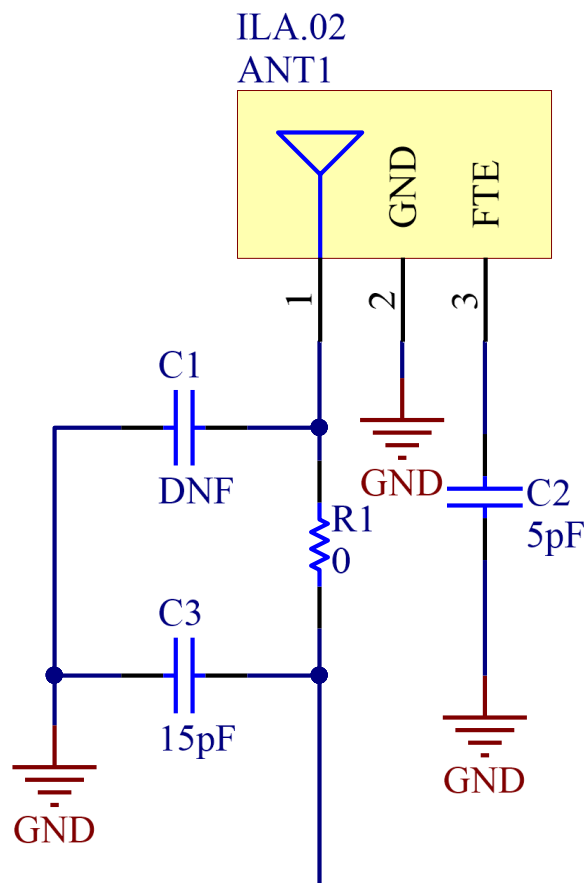

Designator	Type	Value	Manufacturer	Manufacturer Part Number
R1	Resistor	0 Ohms	Yageo	RC0402FR-070RL
C1	Capacitor	Not Fitted	-	-
C2	Capacitor	5pF	Murata	GRM1555D1H5R6DA01D
C3	Capacitor	15pF	Murata	GRM1555C1H150JA01D

7.8 Footprint

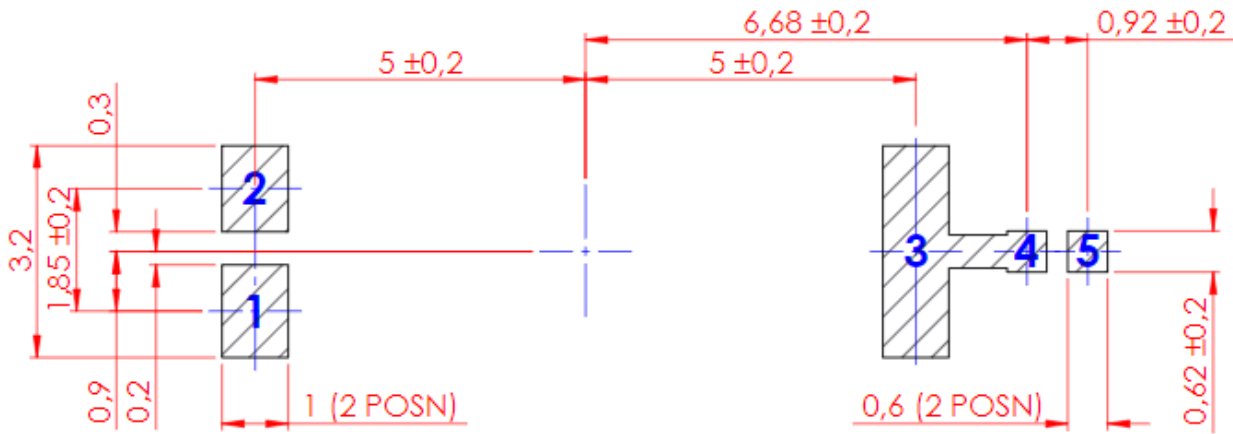

FOOTPRINT PCB

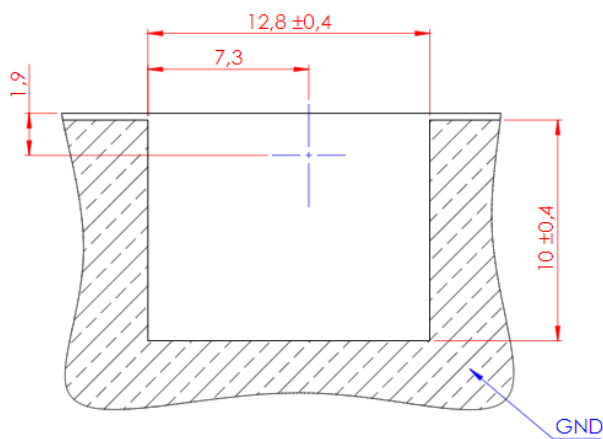

GROUND CLEARANCE BOTTOM VIEW
(SILKSCREEN NOT SHOWN)
SCALE 5:1

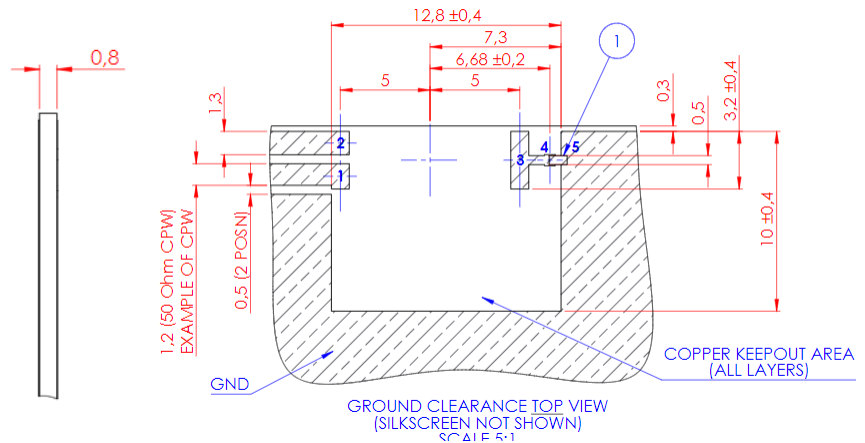

GROUND CLEARANCE TOP VIEW
(SILKSCREEN NOT SHOWN)
SCALE 5:1

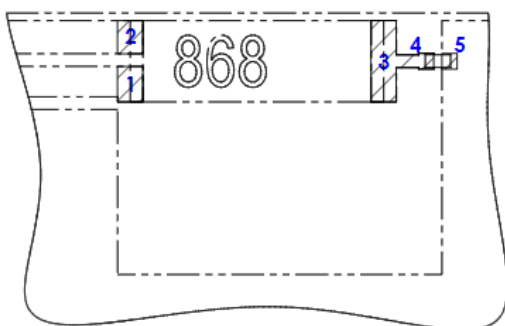

FOOTPRINT SOLDER PADS WITH PCB OUTLINE
SCALE 5:1

PIN:	DESCRIPTION:
1	RF FEED (50 Ohm)
2	GROUND
3	FINE-TUNING ELEMENT
4/5	FINE-TUNING COMPONENT

8. Soldering Reflow Profile

Typical Soldering profile for lead-free process:

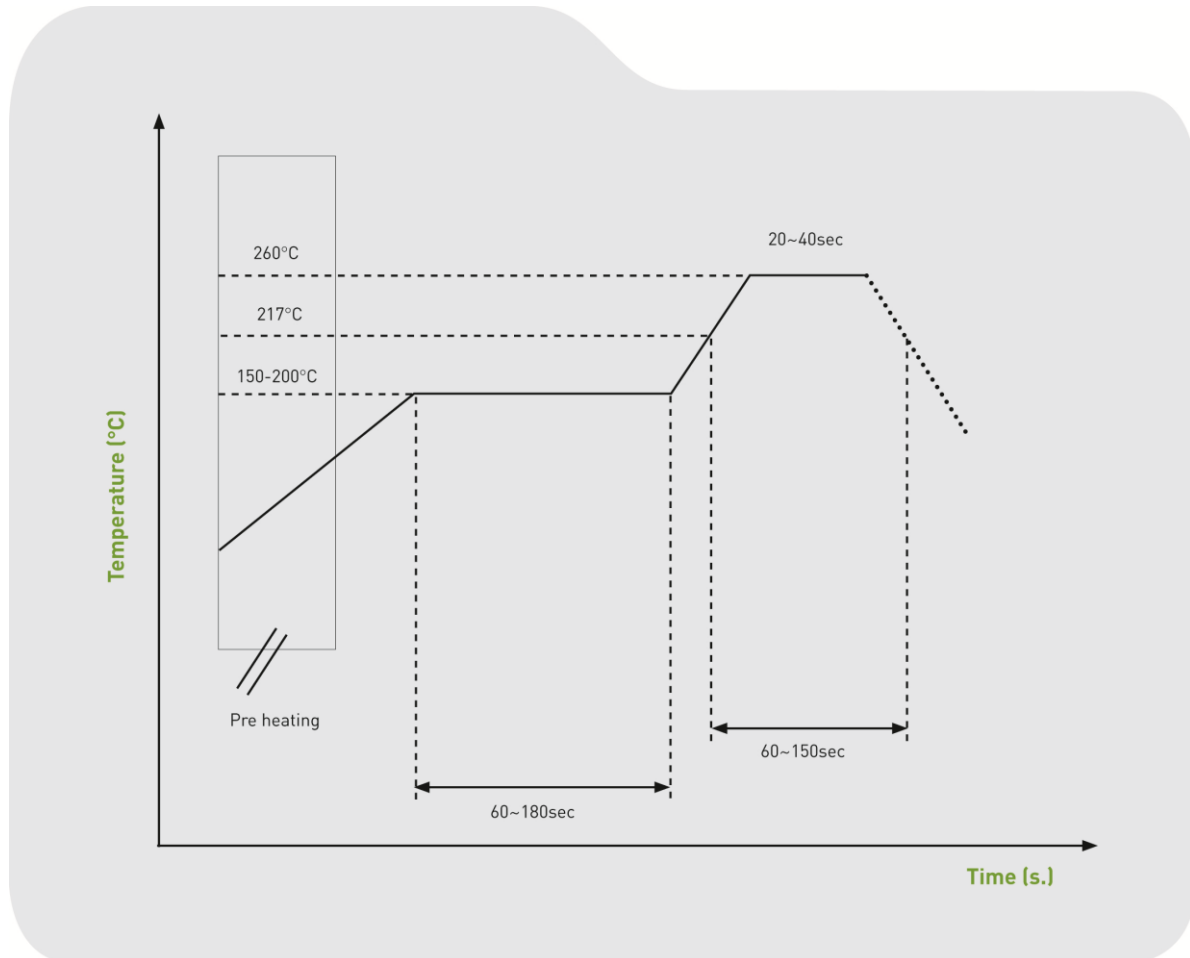

9. Packaging

6000 pcs ILA.02 reel
 Dimensions - 420*380mm
 Weight -1030g

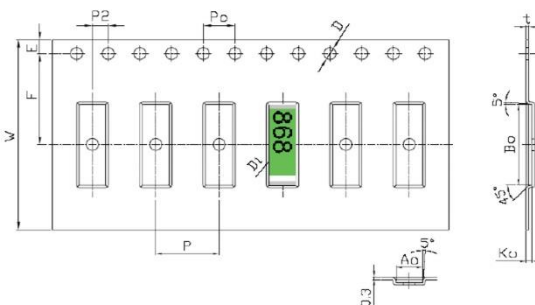
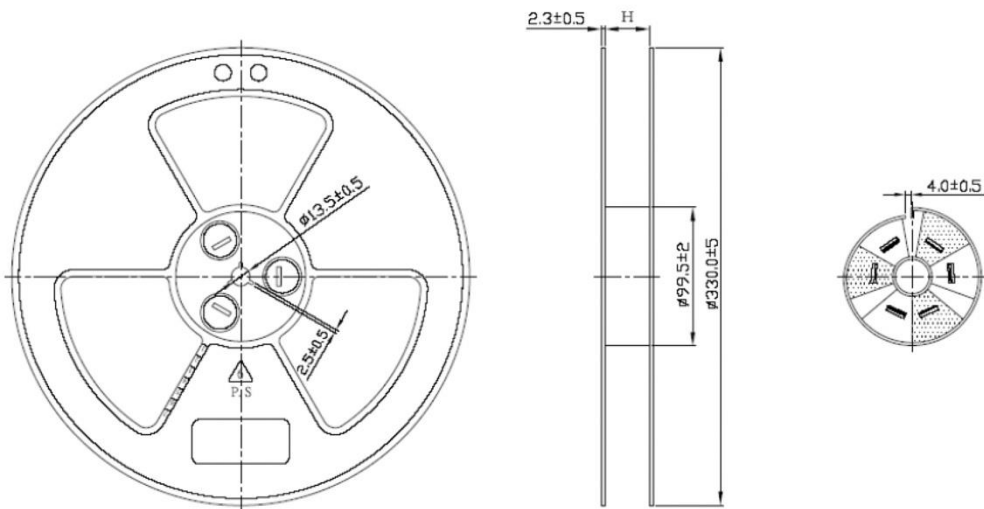

Tape Dimensions(unit: mm)

Feature	Specifications	Tolerances
W	24.00	± 0.30
P	8.00	± 0.10
E	1.75	± 0.10
F	11.50	± 0.10
P2	2.00	± 0.10
D	1.50	+0.10 0.00
D1	1.50	± 0.10
Po	4.00	± 0.10
10Po	40.00	± 0.20

Pocket Dimensions(unit: mm)

Feature	Specifications	Tolerances
Ao	3.40	± 0.10
Bo	10.20	± 0.10
Ko	0.70	± 0.10
t	0.30	± 0.05

6000 pcs ILA.02 reel
Dimensions - 420*380mm
Weight - 1030g

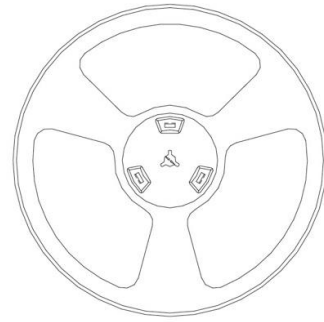

6 reels, 36000pcs
in one carton
Carton Dimensions - 350*350*210mm
Weight - 7Kg

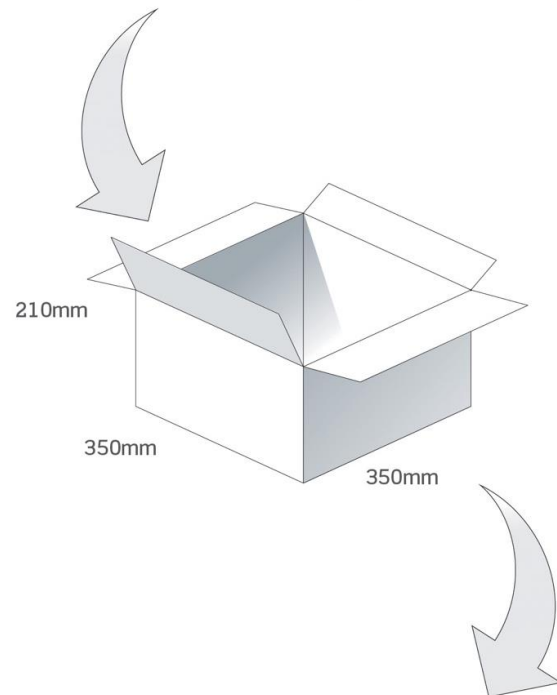

Pallet Dimensions 1200*1000*1460mm
36 Cartons per Pallet
6 Cartons per layer
6 Layers

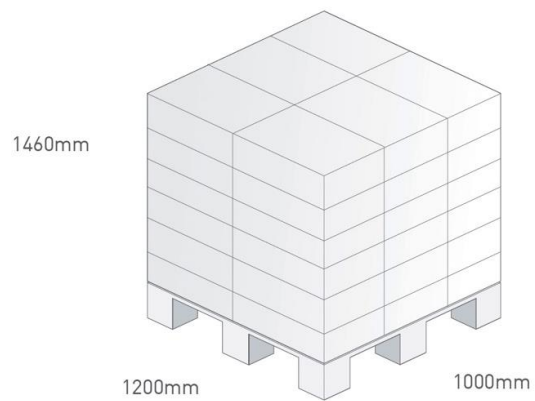

Changelog for the datasheet

SPE-12-8-080– ILA.02

Revision: H (Current Version)

Date:	2022-06-23
Changes:	Updated graphs , radiation patterns and Antenna Installation Guide
Changes Made by:	Evan Murphy

Previous Revisions

Revision: G (Current Version)

Date:	2021-10-28
Changes:	Format Change, MSL
Changes Made by:	Erik Landi

Revision: B

Date:	2012-06-27
Changes:	
Changes Made by:	STAFF

Revision: F

Date:	2017-10-23
Changes:	Packing drawing updated
Changes Made by:	Carol Faughnan

Revision: A (Original First Release)

Date:	2012-05-08
Notes:	Initial Release
Author:	STAFF

Revision: E

Date:	2017-04-21
Changes:	
Changes Made by:	STAFF

Revision: D

Date:	2016-09-12
Changes:	
Changes Made by:	STAFF

Revision: C

Date:	2014-08-19
Changes:	EVB & Footprint
Changes Made by:	AINE DOYLE



TAOGLAS®

www.taoglas.com

