

## How to use the STEVAL-STWINKT1B SensorTile Wireless Industrial Node for condition monitoring and predictive maintenance applications

### Introduction

The STWIN SensorTile wireless industrial node (**STEVAL-STWINKT1B**) is a development kit and reference design that simplifies prototyping and testing of advanced industrial IoT applications such as condition monitoring and predictive maintenance.

It is the updated version of STEVAL-STWINKIT1, now including **STSAFE-A110** populated, **BlueNRG-M2SA** module and **IMP23ABSU** MEMS microphone.

The kit features a core system board with a range of embedded industrial-grade sensors and an ultra-low-power microcontroller for vibration analysis of 9-DoF motion sensing data across a wide range of vibration frequencies, including very high frequency audio and ultrasound spectra, and high precision local temperature and environmental monitoring.

The development kit is complemented with a rich set of software packages and optimized firmware libraries, as well as a cloud dashboard application, all provided to help speed up design cycles for end-to-end solutions.

The kit supports Bluetooth® low energy wireless connectivity through an on-board module, and Wi-Fi connectivity through a special plugin expansion board (**STEVAL-STWINWFV1**). Wired connectivity is also supported via an on-board RS485 transceiver. The core system board also includes an STMod+ connector for compatible, low cost, small form factor daughter boards associated with the STM32 family, such as the LTE Cell pack.

Apart from the core system board, the kit is provided complete with a 480 mAh Li-Po battery, an **STLINK-V3MINI** debugger and a plastic box.

**Figure 1. STEVAL-STWINKT1B SensorTile Wireless Industrial Node**

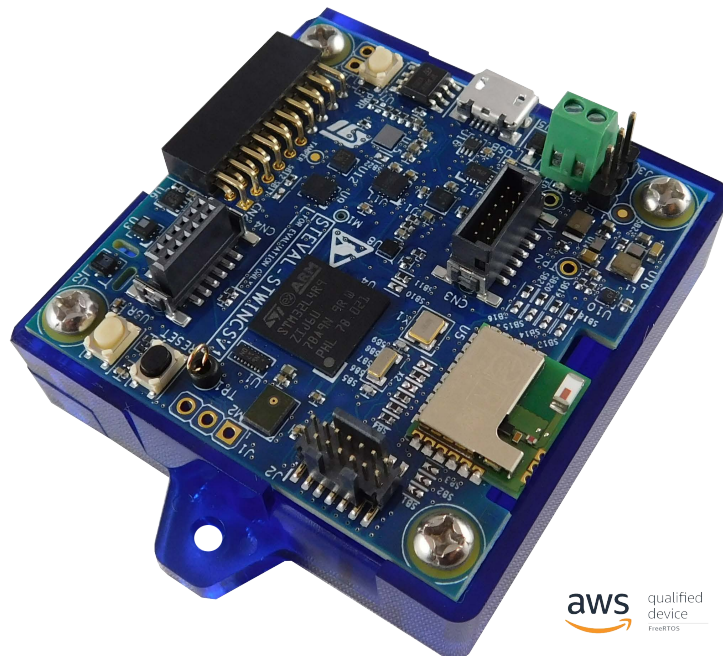

# 1 STWIN kit components

The SensorTile Wireless Industrial Node (STWIN) is packaged with the components shown below.

Figure 2. STWIN Core System board top and bottom

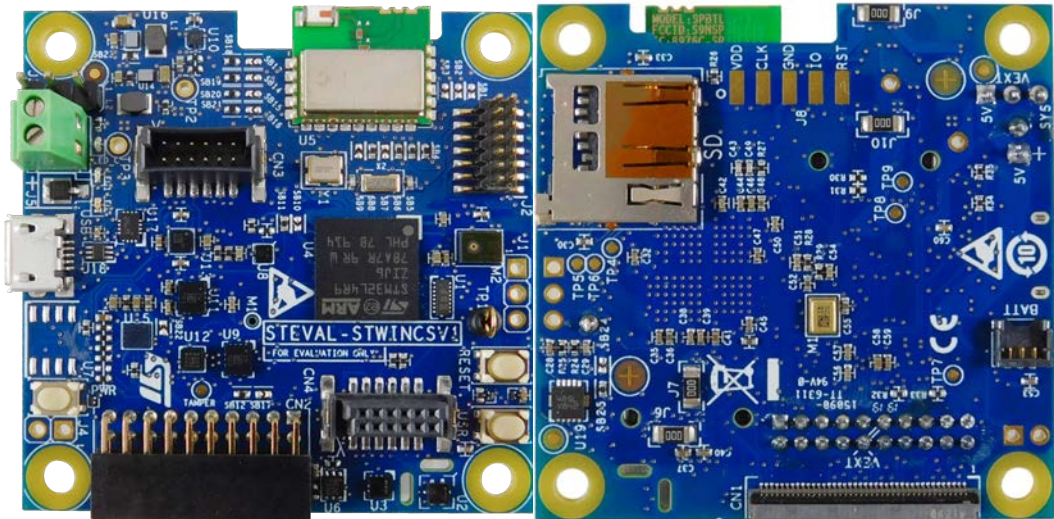

Figure 3. Protective plastic case

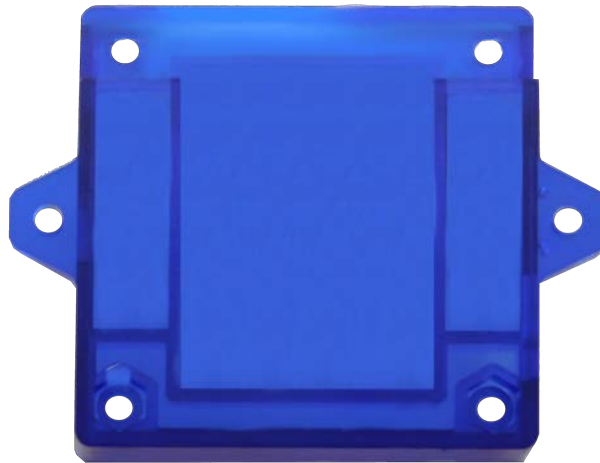

Figure 4. 480mAh 3.7V Li-Po Battery



Figure 5. STLink-V3Mini Debugger/Programmer for STM32

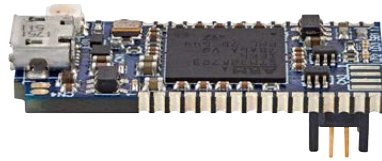
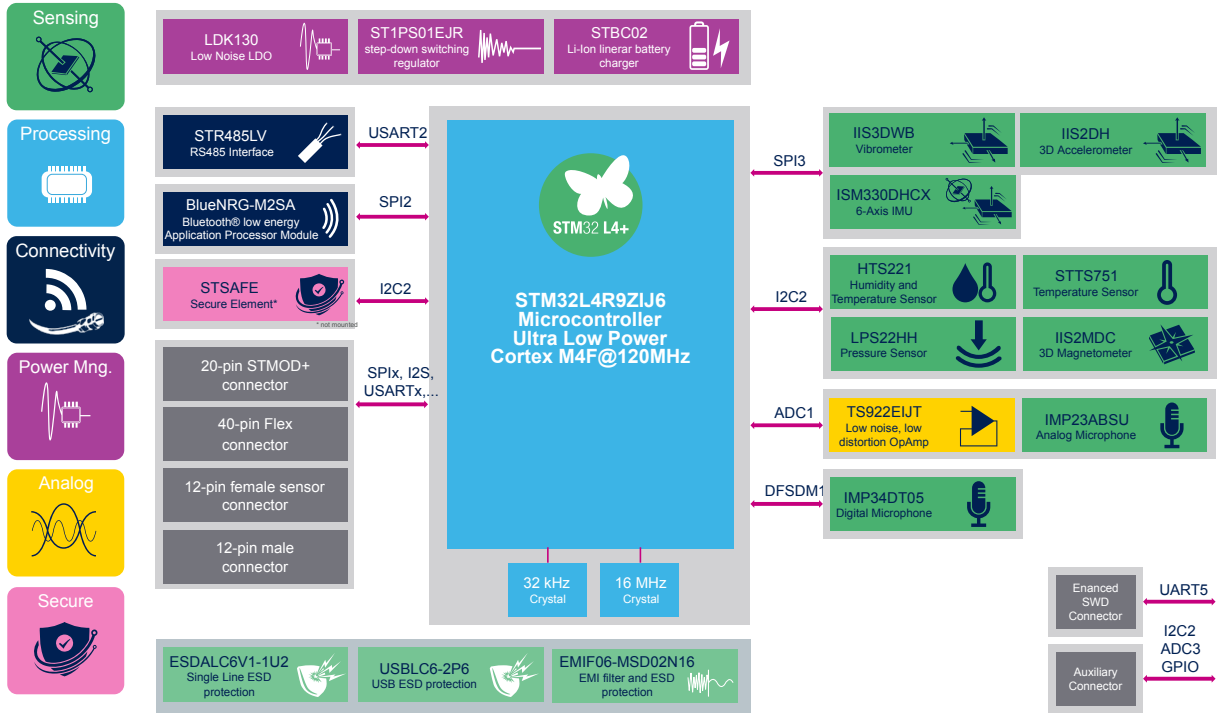

Figure 6. Programming cable



## 2 Functional blocks

Figure 7. STEVAL-STWINKT1B functional block diagram



### 2.1 Sensing

The core system board offers a comprehensive range of sensors specifically designed to support and enable the Industry 4.0 applications.

Figure 8. STEVAL-STWINKT1B functional block diagram of sensing elements and STM32L4R9ZIJ6

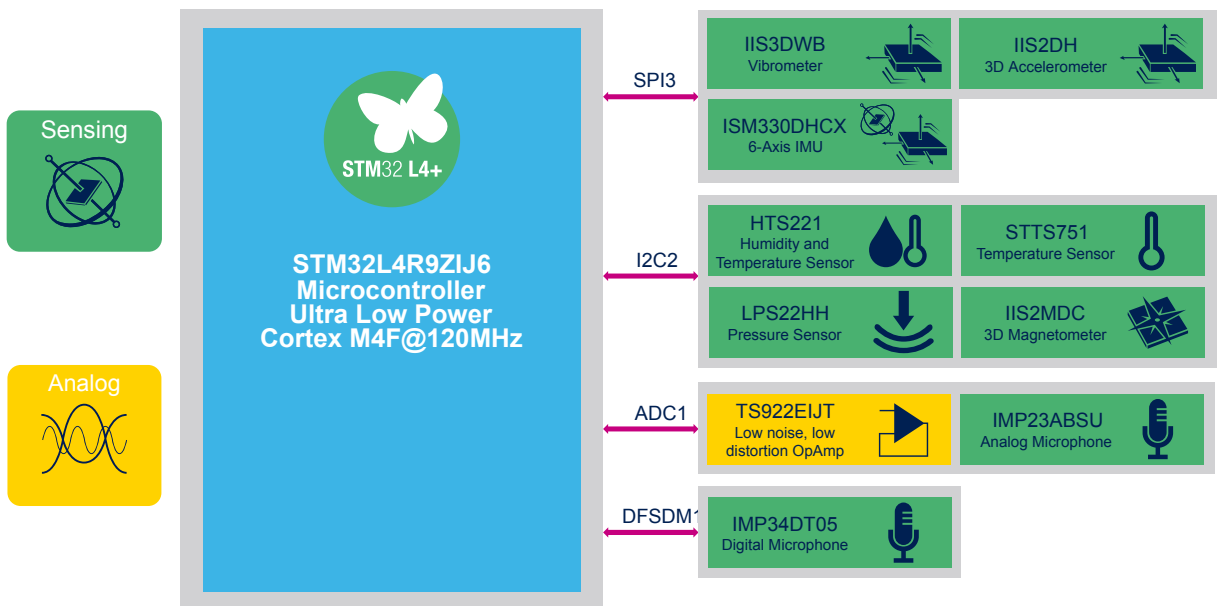

The motion sensors communicate with the [STM32L4R9ZIJ6](#) microcontroller via SPI in order to accommodate the high data rates, while the magnetometer and environmental sensors communicate via I2C.

The suitably filtered signal from the [IMP23ABSU](#) analog microphone is amplified by a [TS922](#) low noise op-amp and then sampled by the internal 12-bit ADC in the MCU, while the signal from digital microphone is directly managed by the digital filter for Sigma-Delta modulators (DFSDM) interface in the MCU.

**Figure 9. Core system board sensor locations**

- U2: [HTS221](#) relative humidity and temperature sensor
- U3: [LPS22HH](#) digital absolute pressure sensor
- U6: [STTS751](#) low-voltage digital local temperature sensor
- U8: [TS922](#) rail-to-rail, high output current, dual operational amplifier
- U9: [ISM330DHCX](#) 3D acc. + 3D gyro iNEMO IMU with machine learning core
- U11: [IIS3DWB](#) ultra-wide bandwidth (up to 6 kHz), low-noise, 3-axis digital vibration sensor
- U12: [IIS2DH](#) ultra-low-power high performance MEMS motion sensor
- U13: [IIS2MDC](#) ultra-low-power 3-axis magnetometer
- M1: [IMP23ABSU](#) analog MEMS microphone
- M2: [IMP34DT05](#) industrial grade digital MEMS microphone

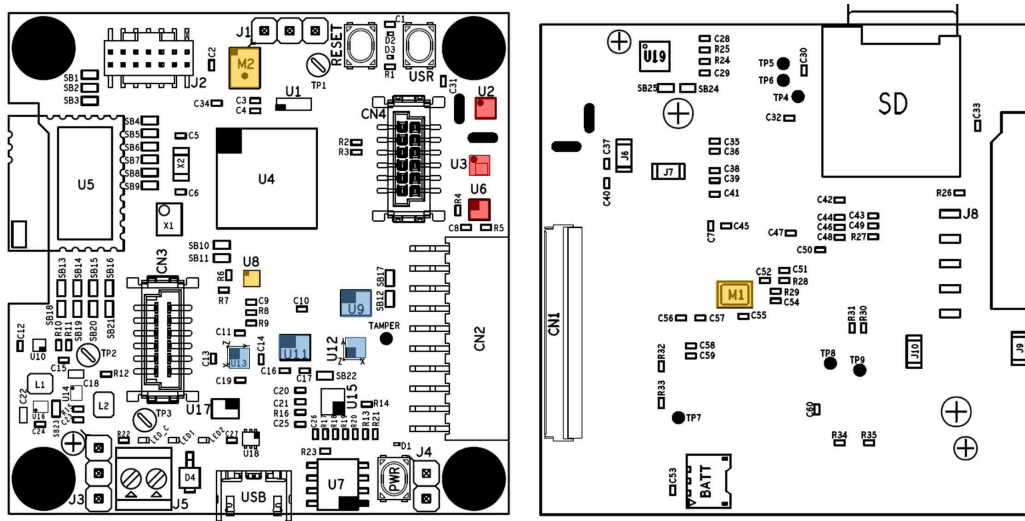

### 2.1.1 HTS221 humidity and temperature sensor

The [HTS221](#) is an ultra-compact relative humidity and temperature sensor with a sensing element and a mixed signal ASIC to provide measurement information through digital serial interfaces.

The sensing element consists of a polymer dielectric planar capacitor structure capable of detecting relative humidity variations and is manufactured using a dedicated ST process.

The [HTS221](#) is available in a small top-holed cap land grid array (HLGA) package guaranteed to operate over a temperature range from  $-40\text{ }^{\circ}\text{C}$  to  $+120\text{ }^{\circ}\text{C}$ .

#### RELATED LINKS

[Visit the product web page for the HTS221 relative humidity and temperature sensor](#)

### 2.1.2 LPS22HH MEMS pressure sensor

The [LPS22HH](#) is an ultra-compact piezoresistive absolute pressure sensor which functions as a digital output barometer. The device consists of a sensing element and an IC interface which communicates through I<sup>2</sup>C, MIPI I3CSM or SPI from the sensing element to the application.

The sensing element, which detects absolute pressure, consists of a suspended membrane manufactured using a dedicated process developed by ST.

The [LPS22HH](#) is available in a full-mold, holed LGA package (HLGA). It is guaranteed to operate over a temperature range extending from  $-40\text{ }^{\circ}\text{C}$  to  $+85\text{ }^{\circ}\text{C}$ .

---

**RELATED LINKS**

---

[Visit the product web page for the LPS22HH MEMS pressure sensor](#)

---

**2.1.3 STTS751 digital temperature sensor**

The **STTS751** is a digital temperature sensor which communicates over a 2-wire SMBus 2.0 compatible bus. The temperature is measured with a user-configurable resolution between 9 and 12 bits. At 9 bits, the smallest step size is 0.5 °C, and at 12 bits, it is 0.0625 °C. At the default resolution (10 bits, 0.25 °C/LSB), the nominal conversion time is 21 milliseconds.

Up to eight devices can share the same 2-wire SMBus without ambiguity, allowing a single application to monitor multiple temperature zones.

---

**RELATED LINKS**

---

[Visit the product web page for the STTS751 digital temperature sensor](#)

---

**2.1.4 TS922 rail-to-rail, high output current, dual operational amplifier**

The **TS922** is a rail-to-rail dual BiCMOS operational amplifier optimized and fully specified for 3 V and 5 V operation. The very low noise, low distortion, low offset, and high output current capability render this device highly suitable for high quality, low voltage, or battery operated audio systems.

---

**RELATED LINKS**

---

[Visit the product web page for the TS922 rail-to-rail, high output current, dual operational amplifier](#)

---

**2.1.5 ISM330DHCX iNEMO IMU 3D Acc + 3D Gyro**

The **ISM330DHCX** is a system-in-package featuring a high-performance 3D digital accelerometer and +3D digital gyroscope tailored for Industry 4.0 applications.

The sensing elements of the accelerometer and of the gyroscope are implemented on the same silicon die, which ensures superior stability and robustness.

Several embedded features such as programmable FSM, FIFO, sensor hub, event decoding and interrupts allow the implementation of smart and complex sensor nodes able to deliver high performance at very low power.

---

**RELATED LINKS**

---

[Visit the product web page for the ISM330DHCX iNEMO IMU 3D Acc + 3D Gyro](#)

---

**2.1.6 IIS3DWB ultra-wide bandwidth (up to 6 kHz), low-noise, 3-axis digital vibration sensor**

The **IIS3DWB** is a system-in-package featuring a 3-axis digital accelerometer with low noise over an ultra-wide and flat frequency range. The wide bandwidth, low noise, very stable and repeatable sensitivity, together with the capability of operating over an extended temperature range (up to +105 °C), render the device particularly suitable for vibration monitoring in industrial applications.

The high performance delivered at low power consumption, together with the digital output and embedded digital features like FIFO and interrupts are of primary importance in battery-operated industrial wireless sensor nodes.

---

**RELATED LINKS**

---

[Visit the product web page for the IIS3DWB ultra-wide bandwidth \(up to 6 kHz\), low-noise, 3-axis digital vibration sensor](#)

---

**2.1.7 IIS2DH ultra-low power 3-axis high-performance accelerometer**

The **IIS2DH** is an ultra-low-power high-performance three-axis linear accelerometer with digital I2C/SPI serial interface standard output.

The device may be configured to generate interrupt signals from two independent inertial wake-up/free-fall events, as well as from the position of the device itself.

---

**RELATED LINKS**

---

[Visit the product web page for the IIS2DH ultra-low power 3-axis high-performance accelerometer](#)

---

**2.1.8 IIS2MDC 3-axis magnetometer**

The IIS2MDC is a high-accuracy, ultra-low-power 3-axis digital magnetic sensor. It has a magnetic field dynamic range up to  $\pm 50$  gauss, and includes an I<sup>2</sup>C serial bus interface that supports 100 kHz, 400 kHz, 1 MHz, and 3.4 MHz rates and an SPI serial standard interface.

The device can be configured to generate an interrupt signal from magnetic field detection.

---

**RELATED LINKS**

---

[Visit the product web page for the IIS2MDC 3-axis magnetometer](#)

---

**2.1.9 IMP23ABSU analog MEMS microphone with extended frequency response up to 80 kHz for ultrasound applications**

The IMP23ABSU is a compact, low-power microphone based on a capacitive sensing element and an IC interface.

The sensing element can detect acoustic waves and is manufactured using a special silicon micro-machining process to produce audio sensors.

The IMP23ABSU has an acoustic overload point of 130 dB SPL with a typical 64 dB signal-to-noise ratio.

The IMP23ABSU sensitivity is  $-38$  dBV  $\pm 1$  dB at 94 dB SPL, 1 kHz.

The IMP23ABSU is available in a package compliant with re-flow soldering and is guaranteed to operate over an extended temperature range ( $-40$  to  $+85$  °C).

---

**RELATED LINKS**

---

[Visit the product web page for the IMP23ABSU analog MEMS microphone](#)

---

**2.1.10 IMP34DT05 digital MEMS microphone**

The IMP34DT05 is an ultra-compact, low-power, omnidirectional, digital MEMS microphone built with a capacitive sensing element and an IC interface; the device features 64 dB signal-to-noise ratio and  $-26$  dBFS  $\pm 3$  dB sensitivity.

The IC interface includes a dedicated circuit able to provide a digital signal externally in PDM format.

---

**RELATED LINKS**

---

[Visit the product web page for the IMP34DT05 digital MEMS microphone](#)

---

**2.2 Processing and connectivity**

The STWIN core system board features several wired and wireless connectivity options and the STM32L4R9ZI ultra-low-power microcontroller, which is part of the STM32L4+ series MCUs based on the high-performance Arm Cortex-M4 32-bit RISC core, operating at up to 120 MHz and equipped with 640 Kb SRAM and 2 MB Flash memory.

Figure 10. Main connectivity components and the STM32L4R9ZI processing unit

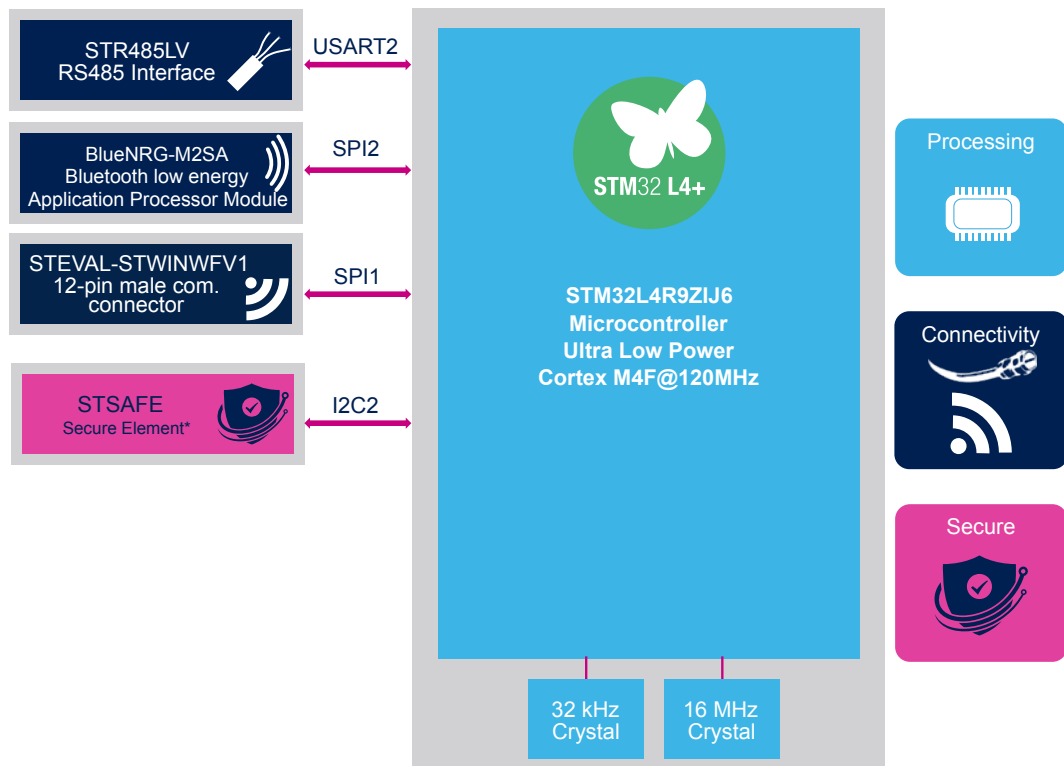

Each connectivity component is connected to an independent bus on the STM32L4R9ZI MCU, so they can all be configured individually.



Figure 11. MCU and connectivity element locations

- U4: STM32L4R9ZI Cortex-M4F 120MHz 640Kb RAM
- U5: BlueNRG-M2SA Very low power application processor module for Bluetooth® low energy v5.0
- U7: STSAFE-A110 authentication and brand protection secure solution
- U17: STG3692 high bandwidth quad SPDT switch
- U19: STR485 3.3V RS485 up to 20Mbps
- USB: Micro-USB connector (power supply + data)
- X1: 16MHz crystal oscillator
- X2: 32.768 kHz crystal oscillator
- J2: STDC14 programming connector for STLINK-V3
- J1: RS485 interface header connector
- CN3: Connectivity expansion connector (for STEVAL-STWINWFV1)
- CN4: Audio/sensor expansion connector
- SD: microSD card socket

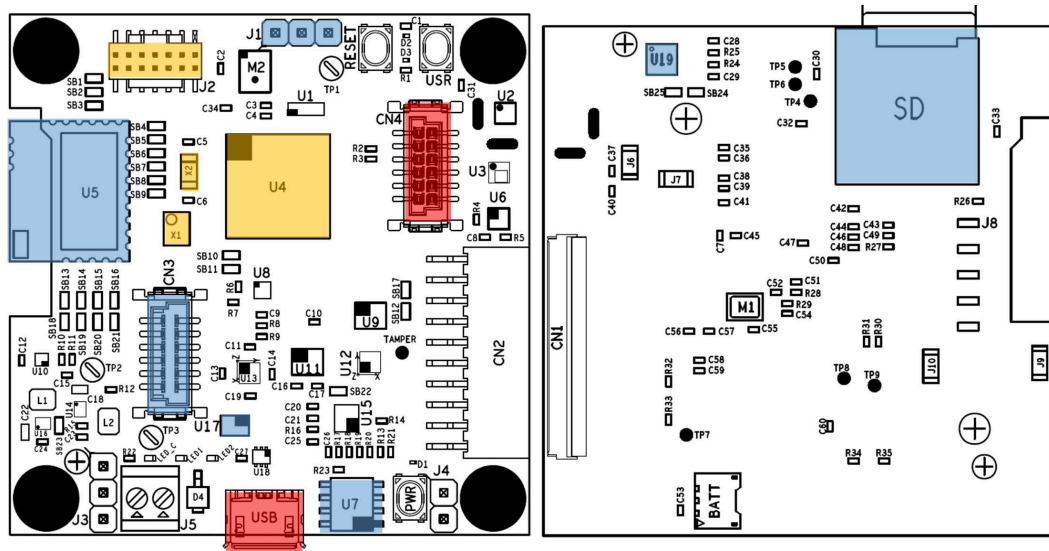

## 2.2.1

### STM32L4R9ZI Cortex-M4F 120MHz 640Kb RAM

The STM32L4R9ZI device is an ultra-low-power microcontroller (STM32L4+ Series MCU) based on the high-performance Arm Cortex-M4 32-bit RISC core, which operates at a frequency of up to 120 MHz.

The Cortex-M4 core features a single-precision floating-point unit (FPU), which supports all the Arm single-precision data-processing instructions and all the data types. The Cortex-M4 core also implements a full set of DSP (digital signal processing) instructions and a memory protection unit (MPU) which enhances application security.

These devices embed high-speed memories (2 Mbytes of Flash memory and 640 Kbytes of SRAM), a flexible external memory controller (FSMC) for static memories (for devices with packages of 100 pins and more), two OctoSPI Flash memory interfaces and an extensive range of enhanced I/Os and peripherals connected to two APB buses, two AHB buses and a 32-bit multi-AHB bus matrix.

The MCU embeds several protection mechanisms for embedded Flash memory and SRAM: readout protection, write protection, proprietary code readout protection and a firewall.

These devices offer a fast 12-bit ADC (5 Msps), two comparators, two operational amplifiers, two DAC channels, an internal voltage reference buffer, a low-power RTC, two general-purpose 32-bit timers, two 16-bit PWM timers for motor control, seven general-purpose 16-bit timers, and two 16-bit low-power timers. The devices support four digital filters for external sigma delta modulators (DFSDM). In addition, up to 24 capacitive sensing channels are available.

They also feature standard and advanced communication interfaces such as:

- Four I2Cs
- Three SPIs
- Three USARTs, two UARTs and one low-power UART
- Two SAls
- One SDMMC

- One CAN
- One USB OTG full-speed
- Camera interface
- DMA2D controller

The device operates in the -40 to +85 °C (+105 °C junction) and -40 to +125 °C (+130 °C junction) temperature ranges from a 1.71 to 3.6 V for  $V_{DD}$  power supply when using internal LDO regulator and a 1.05 to 1.32 V  $V_{DD12}$  power supply when using external SMPS supply. A comprehensive set of power-saving modes allows the design of low-power applications.

Some independent power supplies are supported, such as an analog independent supply input for ADC, DAC, OPAMPs and comparators, a 3.3 V dedicated supply input for USB and up to 14 I/Os, which can be supplied independently down to 1.08 V. A VBAT input allows backup of the RTC and the registers. Dedicated  $V_{DD12}$  power supplies can be used to bypass the internal LDO regulator when connected to an external SMPS.

---

**RELATED LINKS**

---

*[Visit the product web page for the STM32L4R9ZI microcontroller](#)*

---

**2.2.2 BlueNRG-M2 very low power application processor module for Bluetooth® low energy v5.0**

The BlueNRG-M2 is a Bluetooth® low energy system-on-chip application processor certified module compliant with BT specifications v5.0 and BQE qualified. The module simultaneously supports multiple roles and can act at the same time as Bluetooth master and slave device.

The BlueNRG-M2 is based on the BlueNRG-2 system-on-chip and provides a complete RF platform in a tiny form factor, integrating radio, embedded antenna and high frequency oscillators to offer a certified solution that optimizes the final application time-to-market.

The BlueNRG-M2 can be directly powered by a pair of AAA batteries or any power source from 1.7 to 3.6 V.

---

**RELATED LINKS**

---

*[Visit the product web page for the BlueNRG-M2SA application module for Bluetooth® low energy v5.0 wireless technology](#)*

---

**2.2.3 STEVAL-STWINWV1 Wi-Fi expansion (not included in the kit) for the SensorTile wireless industrial node (STWIN) kit**

The STEVAL-STWINWV1 expansion board (sold separately) adds 2.4 GHz Wi-Fi connectivity to the SensorTile Wireless Industrial Node (STWIN) kit.

Through the CN3 connectivity expansion connector, the STEVAL-STWINWV1 can be plugged into the STWIN core system board.

It is based on the ISM43362-M3G-L44-E Wi-Fi module and its main features are:

- 802.11 b/g/n compatible
- based on Broadcom MAC/Baseband/Radio device
- fully contained TCP/IP stack
- host interface: SPI up to 25 MHz

The RF power emitted is +9 dBm (limited by firmware).

The module operating band is 2400 MHz ~ 2483.5 MHz (2.4 GHz ISM Band).

---

**RELATED LINKS**

---

*[Visit the product web page for further details on the STEVAL-STWINWV1](#)*

---

**2.2.4 STR485LV 3.3V RS485 up to 20Mbps**

The STR485 is a low power differential line transceiver for RS485 data transmission standard applications in half-duplex mode. Data and enable signals are compatible with 1.8 V or 3.3 V supplies.

Two speeds are selectable via the SLR pin: fast data rate up to 20 Mbps or slow data rate up to 250 kbps for extended cables.

Excessive power dissipation caused by bus contention or faults is prevented by a thermal shutdown circuit that forces the driver outputs into a high impedance state. The receiver has a fail-safe feature that guarantees a high output state when the inputs are left open, shorted or idle.

---

#### RELATED LINKS

---

[Visit the product web page for the STR485LV 3.3V RS485 up to 20Mbps](#)

---

### 2.2.5 USB connector

The Micro-USB connector on the board can be used for both power supply and data transfer (USB Device only). Different examples of USB class implementation can be found in STSW-STWINKT01 software package.

### 2.2.6 STSAFE-A110 authentication, state-of-the-art security for peripherals and IoT devices

The [STSAFE-A110](#) is a highly secure solution that acts as a secure element providing authentication and secure data management services to a local or remote host. It consists of a full turnkey solution with a secure operating system running on the latest generation of secure microcontrollers.

The [STSAFE-A110](#) can be integrated in IoT devices, smart-home, smart-city and industrial applications, consumer electronics devices, consumables and accessories.

---

#### RELATED LINKS

---

[Visit the product web page for the STSAFE-A110 authentication, state-of-the-art security for peripherals and IoT devices](#)

---

### 2.2.7 microSD card socket

On the bottom side of the STWIN core system board is a microSD Card socket that is accessible even when the board is mounted in the plastic box. The card is accessed through a 4-bit wide SDIO port for maximum performance.

A couple of firmware examples involving high speed data logging on the SD card are available in the [STSW-STWINKT01](#) software package.

### 2.2.8 Clock sources

There are two external clock sources on the STWIN core system board:

- X1: 16 MHz high speed external (HSE) oscillator for the MCU.
- X2: 32.768 kHz low speed external (LSE) oscillator for the RTC embedded in the MCU.

## 2.3 Power management

The STWIN core system board includes a range of power management features that enable very low power consumption in final applications.

The main supply is through a lithium ion polymer battery (3.7 V, 480 mAh) and the integrated battery charger ([STBC02](#)) with  $V_{in}$  [4.8 -5.5 V].

Figure 12. Power and protection components

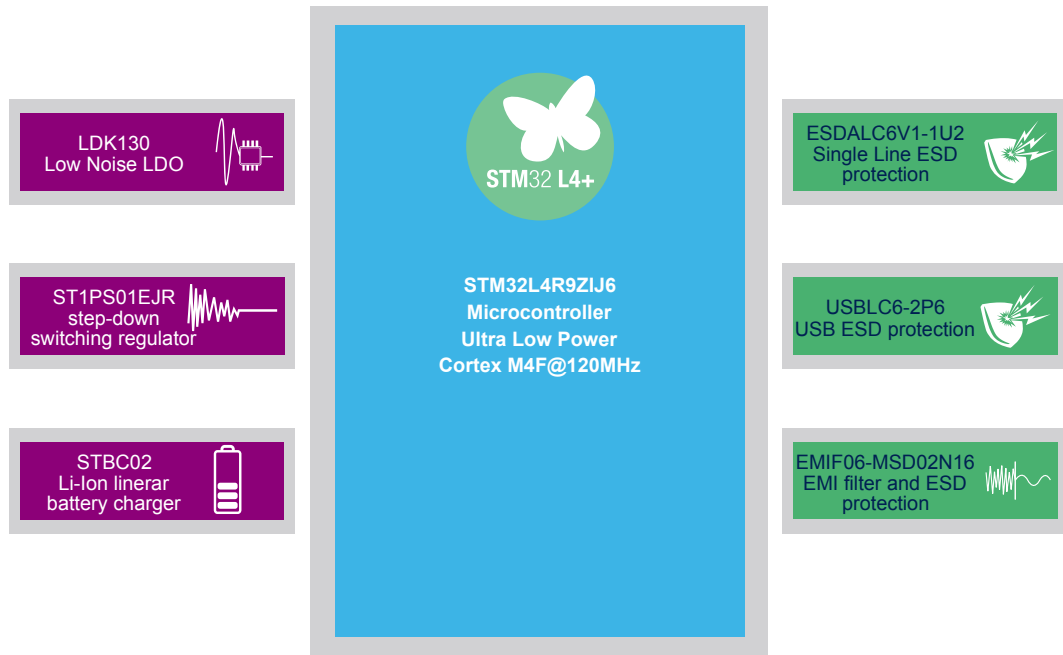
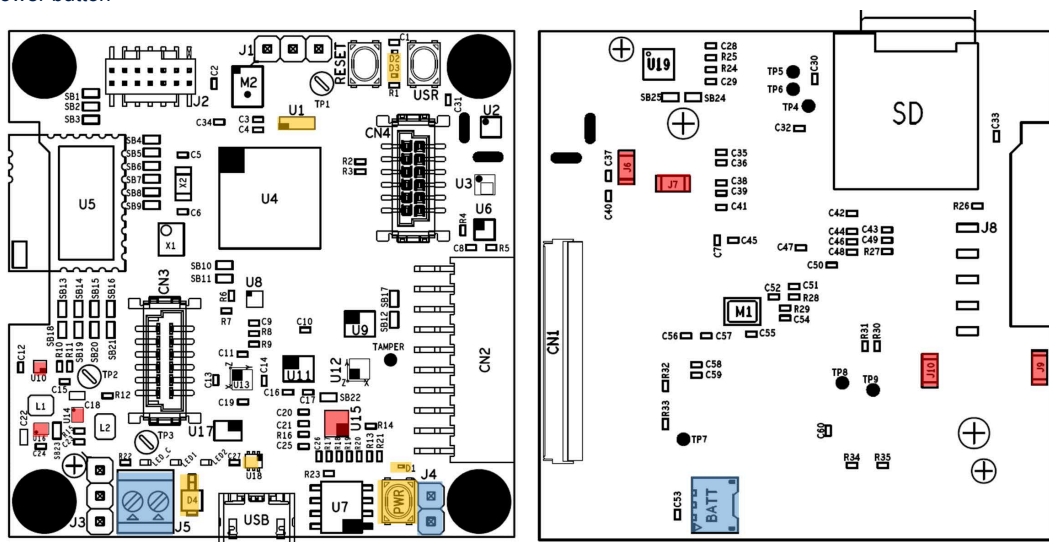

Figure 13. Power and protection component locations

- U1: EMIF06-MSD02N16 6-line EMI filter and ESD protection for T-Flash and microSD card interfaces
- U10: LDK130 300 mA very low noise LDO
- U14, U16: ST1PS01 400 mA Synchronous step-down converter
- U15: STBC02 Li-Ion linear battery charger
- U18: USBLC6-2 low capacitance ESD protection for USB
- D1, D2, D3: Single-line low capacitance Transil for ESD protection
- D4: Power Schottky rectifier (1A)
- BATT: Battery connector
- J4: Battery pins
- J5: 5V Ext power supply connector
- J6, J7, J9, J10: Current monitoring SMD jumper
- PWR: Power button



### 2.3.1 Battery connectors

The battery supply voltage (VBAT) may be provided by connecting the 480 mA LiPo battery included in the STWIN kit to the dedicated battery connector, or by supplying an external voltage through the J4 connector.

Figure 14. Battery and J4 connectors for VBAT supply

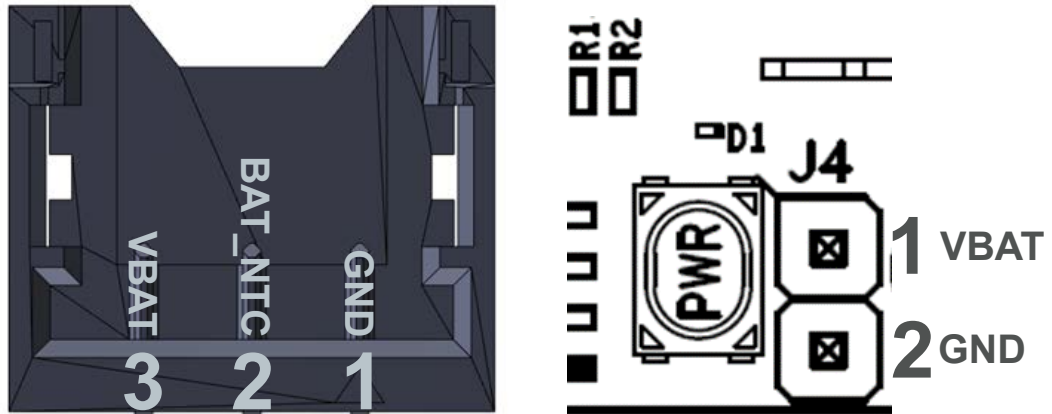

### 2.3.2 Power supply

The STWIN core system board can receive power from different sources:

- V\_USB: through micro USB connector [5 V]
- V<sub>in</sub>: through J5 connector [4.8-5.5 V]. The current on this port needs to be limited to 2 A
- VBAT: lithium ion polymer battery (3.7 V, 480 mAh), STBC02 battery charger integrated in the board

The battery is always optional. The STBC02 battery charger automatically checks the available power inputs and selects one to power the system. When the battery is connected as well as one of the other sources, the STBC02 automatically charges the battery.

When battery-powered, the equipment is intended to work properly with an operating temperature of 35°C.

Without the battery, the equipment is intended to work properly with an operating temperature of 45°C.

Figure 15. Power circuits

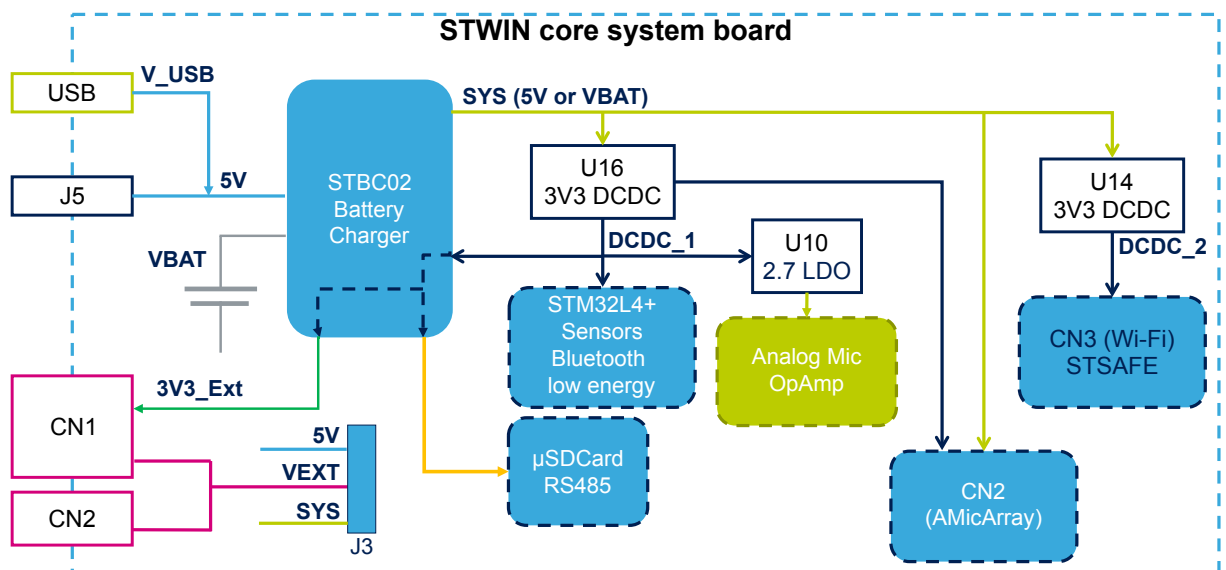

### 2.3.3 Power ON/OFF procedure

If the STWIN core system board is not powered via battery, then the board will turn on and off when you connect and disconnect an external supply, respectively.

Follow the steps below to power the board on and off when it is powered by a LiPo battery.

- Step 1.** Push the PWR button for about a second to power the board on.  
Power on is managed by the **STBC02** battery charger WAKE-UP hardware feature.
- Step 2.** Push the PWR button again to turn the board off.  
In the application code examples provided with the software, the microcontroller detects the push action and activates the battery charger SHUTDOWN command to switch the power supply off.

### 2.3.4 Power consumption evaluation

There are several test points and jumpers on the STWIN core system board available to monitor the electrical performance of running applications. In particular, there are four jumpers for monitoring the current consumption in each of the four main power supply domains on the board.

The best way to evaluate general power consumption is to remove both the battery and the USB cable and provide 5 V directly on the J5 connector.

Figure 16. Power monitoring points

- J6: Sensor current monitoring
- J4: Battery supply
- J7: STM32 digital power supply current monitoring
- J9: BlueNRG-M2SA Bluetooth® low energy module current monitoring
- J10: STEVAL-STWINWFV1 (Wi-Fi expansion) and STSAFE-A110 current monitoring
- TP1, TP2: GND
- TP3: DCDC\_1 (3.3V)

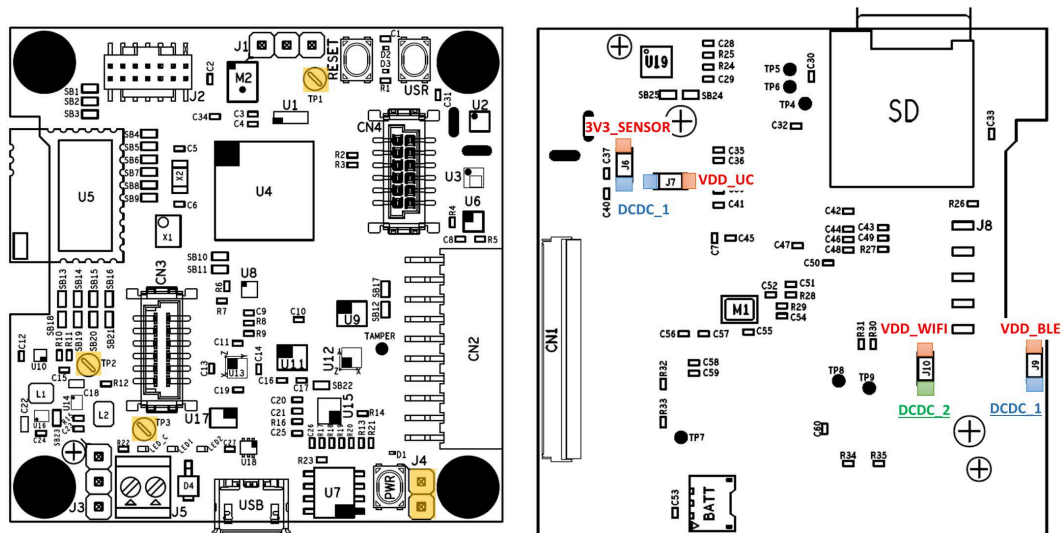

## 2.4 Buttons, LEDs and connectors

**Figure 17. Buttons, LEDs and connectors**

USR: User button

PWR: connected to the **STBC02** for integrated WAKE-UP function and the **STM32L4R9ZI** MCU as generic USR button

RESET: connected to STM32 MCU reset pin (BLACK)

LED\_C: Red LED connected to **STBC02** and used for battery status feedback

LED1: Green LED connected to STM32

LED2: Orange LED connected to STM32

CN1: 40-pin flex general purpose expansion

CN2: STMod+ connector

CN3: 12-pin male connectivity expansion connector, suitable for the **STEVAL-STWINWV1** expansion board

CN4: 12-pin female sensor expansion connector, suitable for the **STEVAL-STWINMAV1** analog microphone array expansion board

Batt

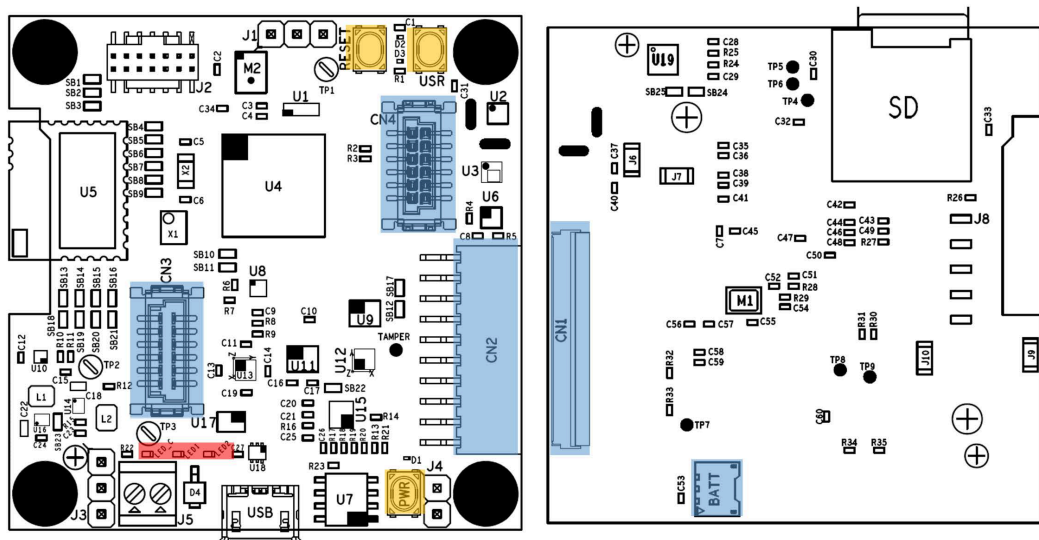

Pin No.	Description	STM32 pin	Default Signal	
7	I2C4_SCL	PD12	-	
8	SPI2_MOSI_p2	PB15	-	
9	SPI2_MISO_p2	PC2	-	
10	I2C4_SDA	PD13	-	
11	PC5/WKUP5	PC5	WKUP5	
12	EX_RESET	PD11	-	
13	EX_ADC	PA5	-	
14	EX_PWM	PA15	-	
15	VEXT	-	-	
16	GND	-	-	
17	PG12	PG12	EX_CN (ex tint)	SAI2
18	PG10	PG10	TIM	
19	PG9	PG9	TIM	
20	PB14	PB14	TIM, DSFDMD2	
21	PA9	PA9	-	
22	PA10	PA10	-	
23	PB11	PB11	DSI_TE, TIM, LPUART_TX	
24	PC13	PC13	TAMP, WKUP	
25	PB9	PB9	CAN, TIM, DSFDMD, I2C1	
26	PB8	PB8		
27	PE9	PE9	TIM, DSFDMDCLK	
28	3V3_Ext	-	-	
29	DSI_D1_N	-	STM32 Display Serial Interface (DSI) Host	
30	DSI_D1_P	-		
31	GND	-	-	
32	DSI_D0_N	-	STM32 Display Serial Interface (DSI) Host	
33	DSI_D0_P	-		
34	SYS	-	-	
35	DSI_CLK_N	-	STM32 Display Serial Interface (DSI) Host	
36	DSI_CLK_P	-		
37	3V3_Ext	-	-	
38	PA0	PA0	ADC_IN5	
39	PA1	PA1	ADC_IN6	
40	SYS	-	-	

### RELATED LINKS

[View the vendor documentation on handling FH34SRJ series connectors](#)



## 2.4.2 STMod+ connector

Figure 19. STMod+ connector top views

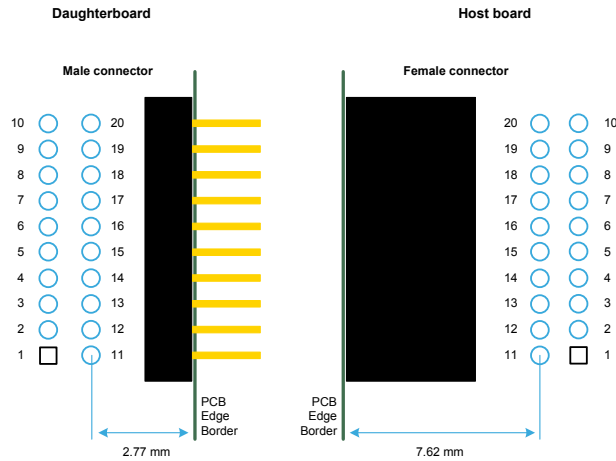

Table 2. STMod+ connector pin assignments and descriptions

STMod+ Pin number	Function <sup>(1)</sup> of the primary host mapped	Description
1	SPIx_NSS <sup>(2)</sup> / UARTy_CTS	Output / Input
2	SPIx_MOSIp <sup>(3)</sup> / UARTy_TX Output / Output	Output / Output
3	SPIx_MISOp <sup>(4)</sup> / UARTy_RX Input / Input	Input / Input
4	SPIx_SCK / UARTy_RTS Output / Output	Output / Output
5	GND Ground Reference	Ground reference
6	+5 V Power Supply <sup>(5)</sup>	Power supply
7	I2Cz_SCL Input / Output	Input / Output
8	SPIx_MOSIs <sup>(3)</sup> Output	Output
9	SPIx_MISOs <sup>(4)</sup> Input / Output	Input / Output
10	I2Cz_SDA Input / Output	Input / Output
11	INT <sup>(6)</sup> Input	Input
12	RESET Output	Output
13	ADC Input	Input
14	PWM Output	Output
15	+5 V Power Supply <sup>(5)</sup>	Power supply
16	GND Ground Reference	Ground reference
17	GPIO <sup>(7)</sup>	Output / Input
18	GPIO <sup>(7)</sup>	Output / Input
19	GPIO <sup>(7)</sup>	Output / Input
20	GPIO <sup>(7)</sup>	Output / Input

1. If two functions are provided on a STMod+ connector pin, you can connect two different I/O ports from STM32: the firmware manages the conflicts that may arise. MOSIs means used in Serial Daisy Chained-SPI mode and MOSIp means used in Parallel SPI mode. More alternate functions may be available from STM32, refer to the User manual of the host board and the corresponding STM32 datasheet available on [www.st.com](http://www.st.com).

2. Instead of SPIx\_NSS, a GPIO can be used as SPI Chip Select.

3. Pins 2 and 8 are the same SPIx\_MOSI signals, but they must come from two different I/O ports.

4. Pins 3 and 9 are the same SPIx\_MISO signals, but they must come from two different I/O ports.
5. Power Supply is Output or Input, depending on host / daughterboard configuration.
6. INT is an interrupt line.
7. GPIO ports with many alternate functions (like UART, I<sup>2</sup>C, SPI and analog inputs/outputs) are privileged to offer optimum flexibility.

---

**RELATED LINKS**



---

[Read TN1238: STMod+ interface specification available on the ST website for more information](#)

---

### 2.4.3 Connectivity expansion connector

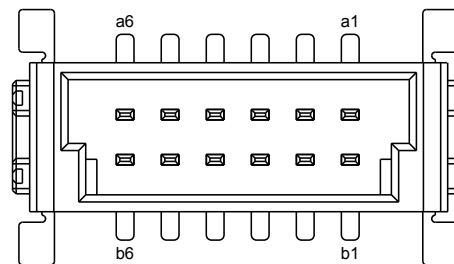
**Figure 20. CN3 connectivity connector top view**



This connector is suitable for the [STEVAL-STWINWFV1](#) Wi-Fi expansion board.

**Table 3. CN3 pin descriptions**

Pin	Description	STM32 pin	Pin	Default Signal	STM32 pin
a1	GND	-	b1	WIFI_DRDY	PE11
a2	CS/USART3_CTS	PB13	b2	WIFI_WAKEUP	PD7
a3	SPI1_CLK/USART3_RTS	PB1	b3	WIFI_BOOT0	PF12
a4	SPI1_MISO/USART3_RX	PD9	b4	WIFI_RST	PC6
a5	SPI1_MOSI/USART3_TX	PD8	b5	I2C3_SDA	PG8
a6	3V3 Output (VDD_WIFI)	-	b6	I2C3_SCL	PG9

### 2.4.4 Sensor expansion connector

**Figure 21. CN4 sensor connector top view**

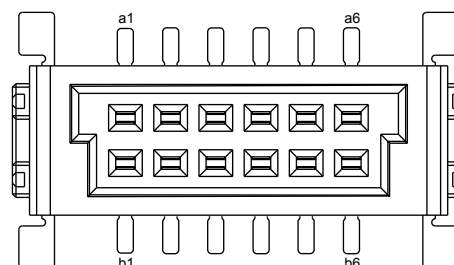

This connector is suitable for the [STEVAL-STWINMAV1](#) analog microphone expansion board.

Table 4. CN4 pin descriptions

Pin	Description	STM32 pin	Pin	Default Signal	STM32 pin
a1	5V/Batt Output	-	b1	DFSDM1_D7	PB10
a2	3V3 Output	-	b2	DFSDM1_CKOUT	PE9
a3	SAI1_FS_A - DFSDM_D3	PE4	b3	I2C2_SCL	PF1
a4	GND	-	b4	I2C2_SDA	PF0
a5	SAI1_SD_A/ SAI1_SD_B/DFSDM_D2	PE6	b5	SAI1_SCK_A	PE5
a6	GND	-	b6	SAI1_MCLK_A/DFSDM_D5	PE2

## 2.5 Protective plastic box

The plastic case is designed to protect and hold the STWIN core system board and the LiPo battery together. The case can also house two magnets (not included in the [STEVAL-STWINKT1B](#) kit), allowing you to stick the wireless industrial node on appropriate metallic areas in the monitored equipment.

### RELATED LINKS

*The system was tested with the following 25x8x3mm magnets*

## 2.6 STLINK-V3MINI debugger and programmer for STM32

The [STLINK-V3MINI](#) is a standalone debugging and programming mini probe for STM32 microcontrollers, with JTAG/SWD interfaces for communication with any STM32 microcontroller located on an application board. It provides a Virtual COM port interface for host PCs to communication with target MCUs via UART. The STLINK-V3MINI is supplied with an STDC14 to STDC14 flat cable.

Figure 22. STLINK-V3MINI and STDC14 cable

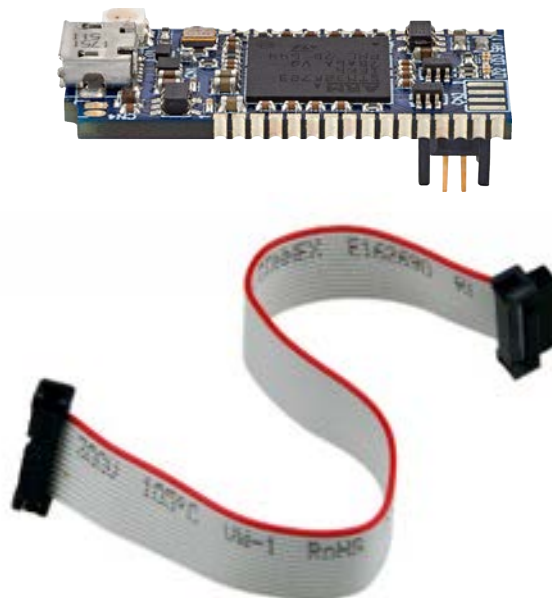

## 3 How to program the board

### 3.1 How to program STWIN with STLINK-V3MINI

Follow the procedure below to program the STWIN core system board.

- Step 1.** Connect the STWIN core system board to the [STLINK-V3MINI](#) programmer using the 14-pin flat cable. The programmer and the cable are included in the [STEVAL-STWINKT1B](#) hardware kit.
- Step 2.** Connect both the boards to a PC using micro USB cables.

**Figure 23. STLINK-V3MINI connected to STWIN core system board**

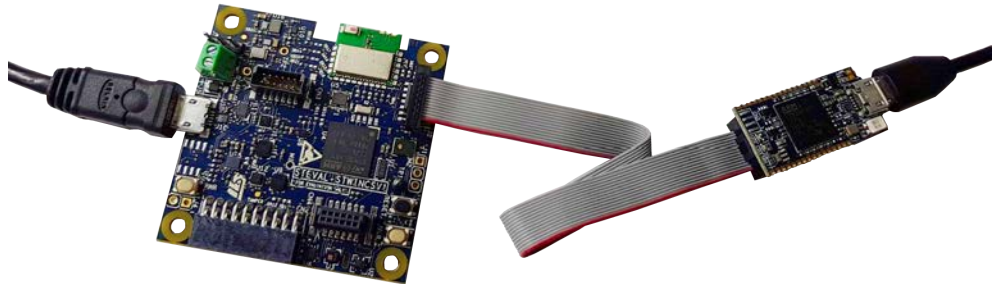

- Step 3.** Download the firmware onto the core system board; you can either:
  - download one of the sample application binaries provided using [STM32CubeProgrammer](#) or [ST-LINK Utility](#)
  - recompile one of the projects with your preferred IDE (EWARM, Keil, [STM32CubeIDE](#))

### 3.2 How to program STWIN without STLINK-V3MINI using STM32CubeProgrammer "USB mode"

The [STEVAL-STWINKT1B](#) can also be reprogrammed via USB using the [STM32CubeProgrammer](#) "USB mode". To enter "Firmware upgrade" mode you must follow the procedure below:

- Step 1.** Unplug the STWIN core system board.
- Step 2.** Press the USR button.
- Step 3.** While keeping the button pressed, connect the USB cable to the PC. Now the board is in DFU mode.

**Step 4.** You can upgrade the firmware by following the steps below:

**Step 4a.** Open STM32CubeProgrammer.

**Step 4b.** Select [USB] on the top-right corner.

**Figure 24. STM32CubeProgrammer - USB mode selection**

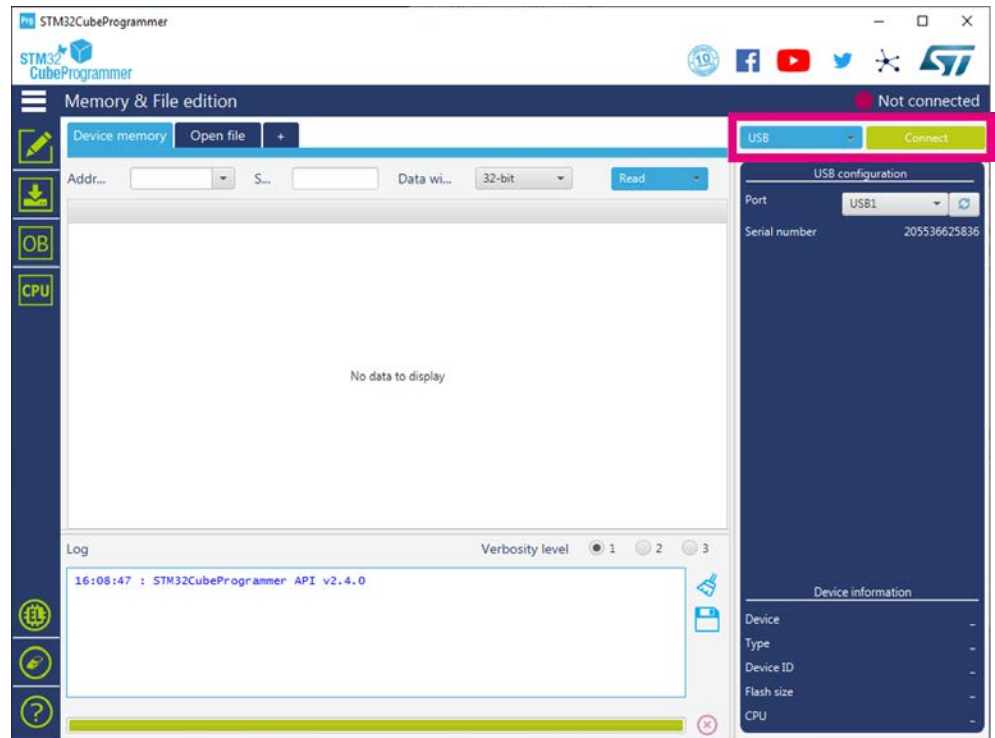

**Step 4c.** Click on [Connect].

Figure 25. STM32CubeProgrammer - connection

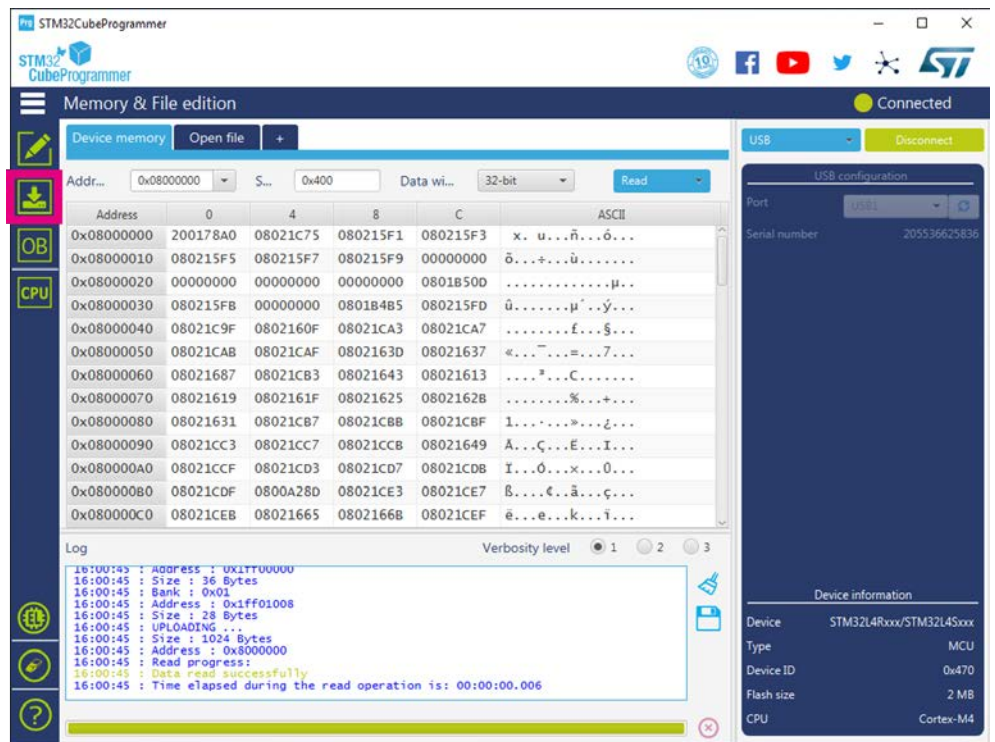

Step 4d. Go to the [Erasing & Programming] tab.

Step 4e. Search for the new .bin or .hex binary file to be flashed into the board.

Step 4f. Click on [Start Programming].

Figure 26. STM32CubeProgrammer - programming

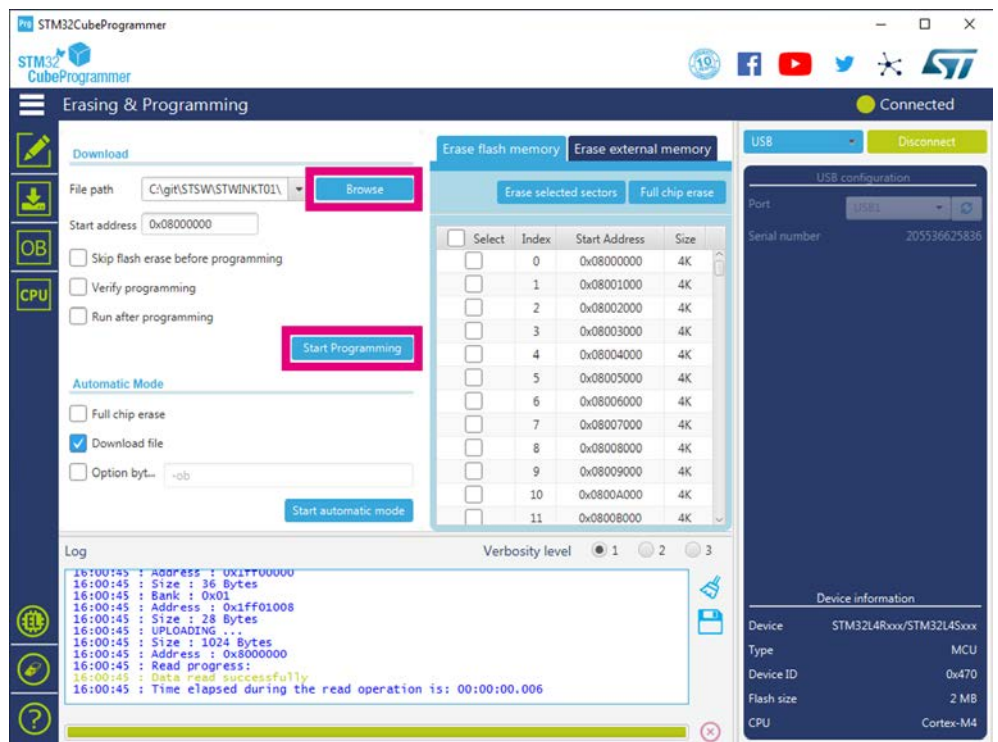

## 4 STWIN assembly steps

To assemble your SensorTile Wireless Industrial Node, you need the following components:

- STWIN core system board
- 4x M3 bolts and nuts
- Plastic box (2 parts)
- Battery
- 2x Magnets (optional - not included in the kit):
  - RS Stock No. 177-4040 Brand Eclipse Mfr Part No.N859

**Figure 27. Exploded cad drawing of STWIN node components**

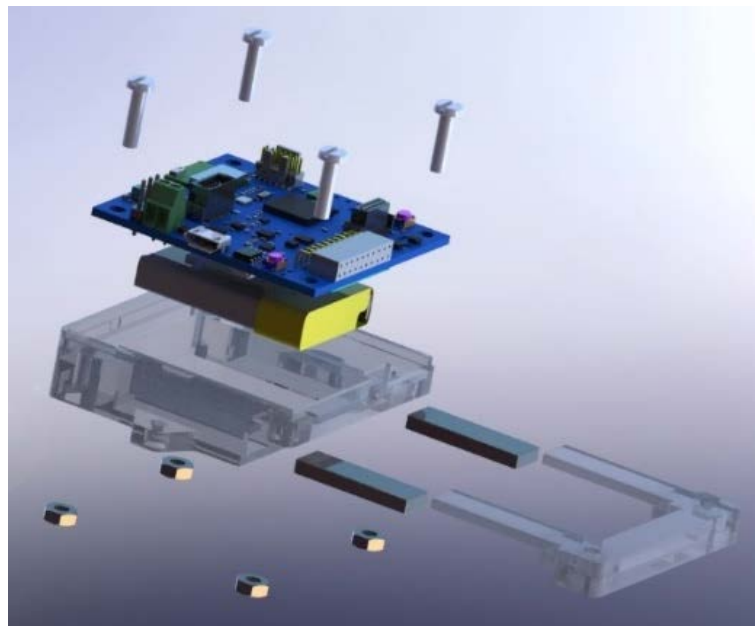

- Step 1.** (Optional) Insert the magnets in the rectangular recesses in the bottom of the main case.

**Figure 28. Optional magnets inserted in main case**

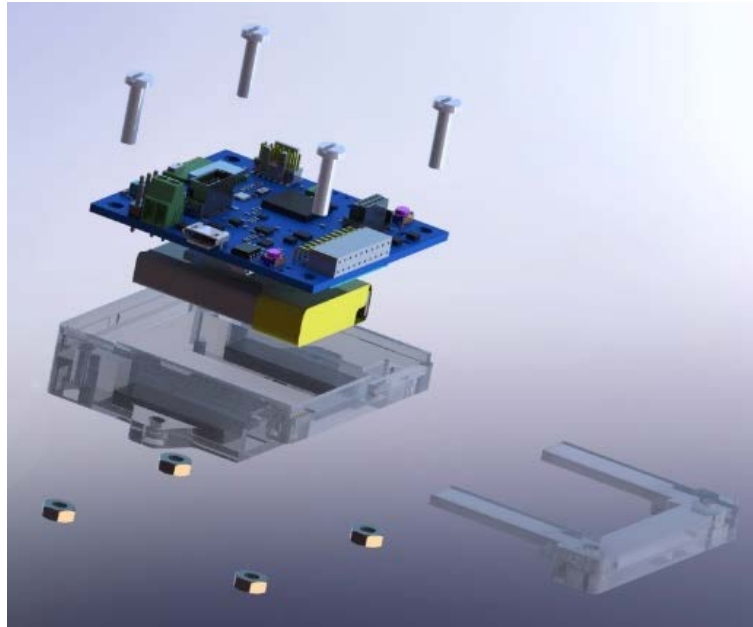

- Step 2.** Slide the U-shaped bracket into the main case. This will secure the magnets if they are present.
- Step 3.** Insert the STWIN core system board with the correct orientation.

**Figure 29. Core system board inserted in main case**

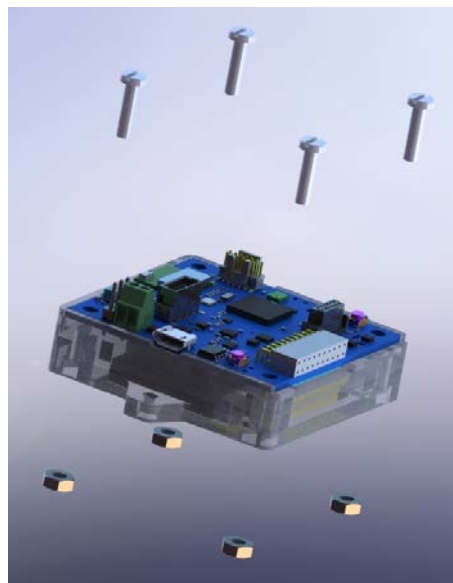



- Step 4.** Fasten the core system board to the case using the nuts and bolts provided with the kit.

**Figure 30.** Core system board fastened with bolts



## 5 How to run the HSDatalog application

The HSDatalog (High-Speed Datalog) application is part of the [FP-SNS-DATALOG1 STM320DE](#) function pack. It allows you to save data from any combination of sensors and microphones configured up to their maximum sampling rate. Sensor data are stored on a micro SD Card, SDHC (Secure Digital High Capacity) formatted with the FAT32 file system, or can be streamed to a PC via USB.

At startup, the application tries to load the device configuration from the SD card (if any) and then goes to Idle state, waiting for the start command either via USB, push button or Bluetooth® low energy.

**Figure 31. HSDatalog data flow**

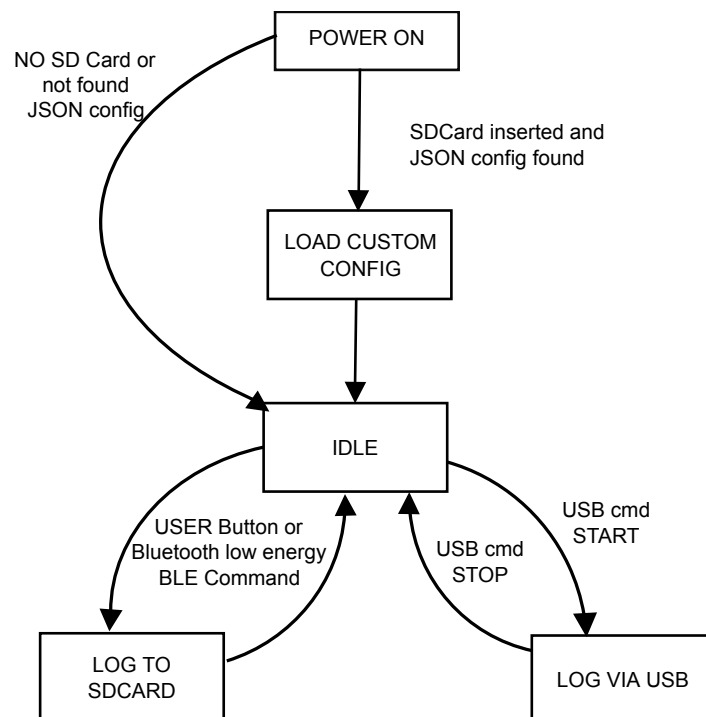

Together with HSDatalog application, inside the Utilities folder, MATLAB and Python scripts are available to automatically read and plot the data saved by the application.

The script has been successfully tested with MATLAB v2019a and Python 3.7.

The 'ReadSensorDataApp.mlapp' MATLAB app is also available, developed and tested using the App Designer tool available in MATLAB v2019a.

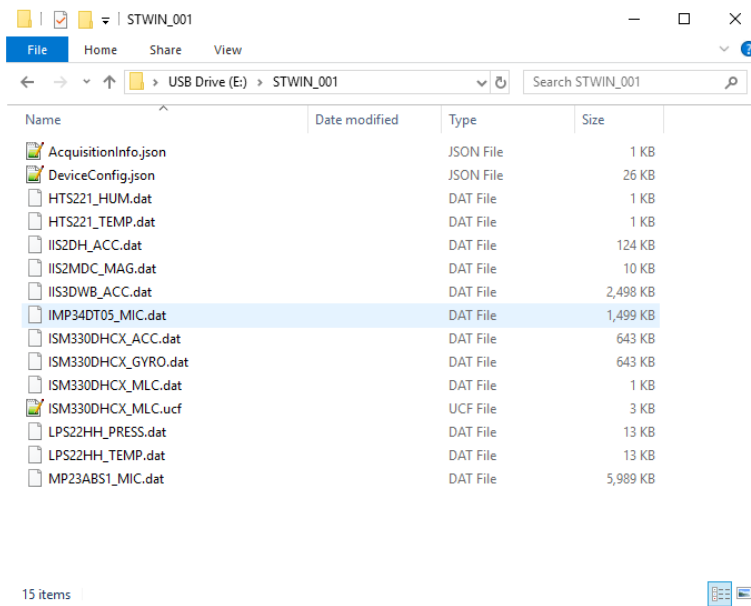
**Figure 32. Folder structure in the SD card**

The script performs the following actions:

- Reads and decodes the JSON file
- Reads the raw data and uses the information from the JSON to translate them into readable data (data + timestamp)
- Plots the data

*Note:* The handling of JSON scripts requires MATLAB v2019a or above.



Figure 34. STEVAL-STWINKT1B schematic (2 of 7)

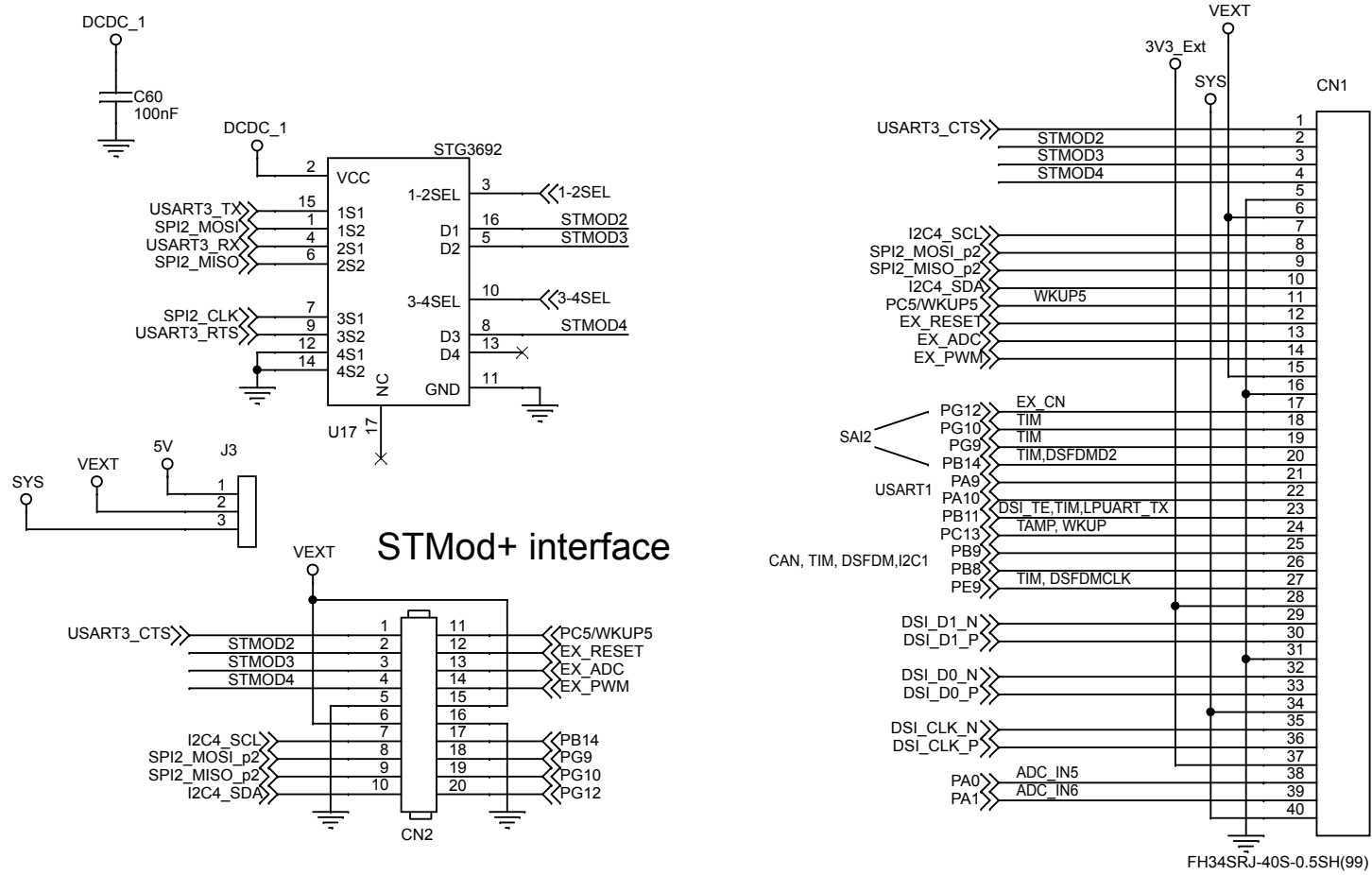

Figure 35. STEVAL-STWINK1B schematic (3 of 7)

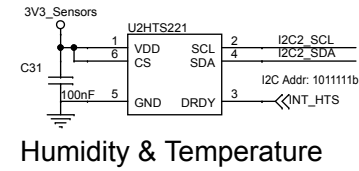
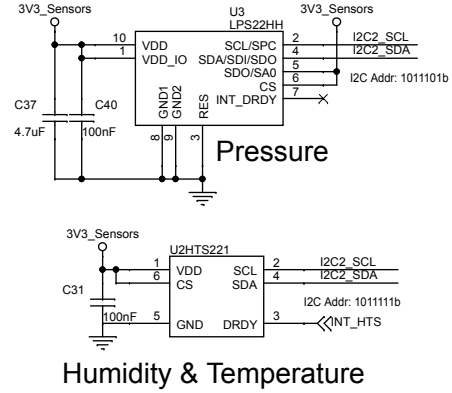
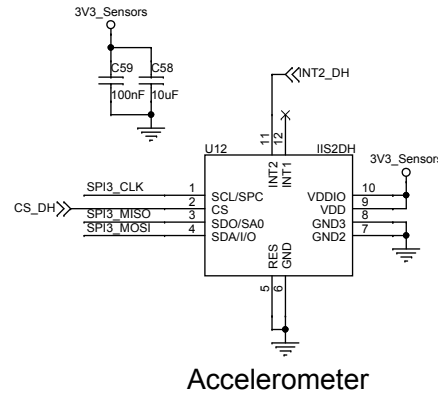
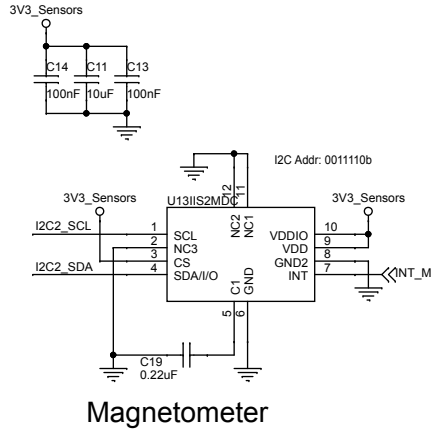
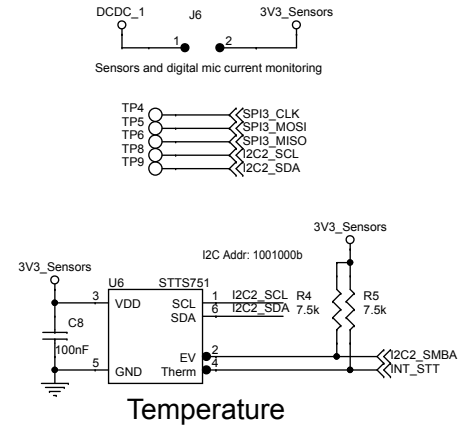
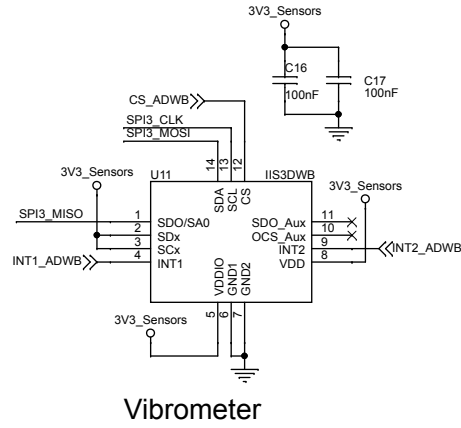
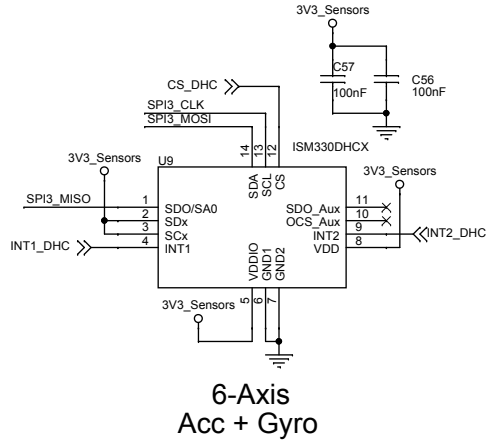

Figure 36. STEVAL-STWINKT1B schematic (4 of 7)

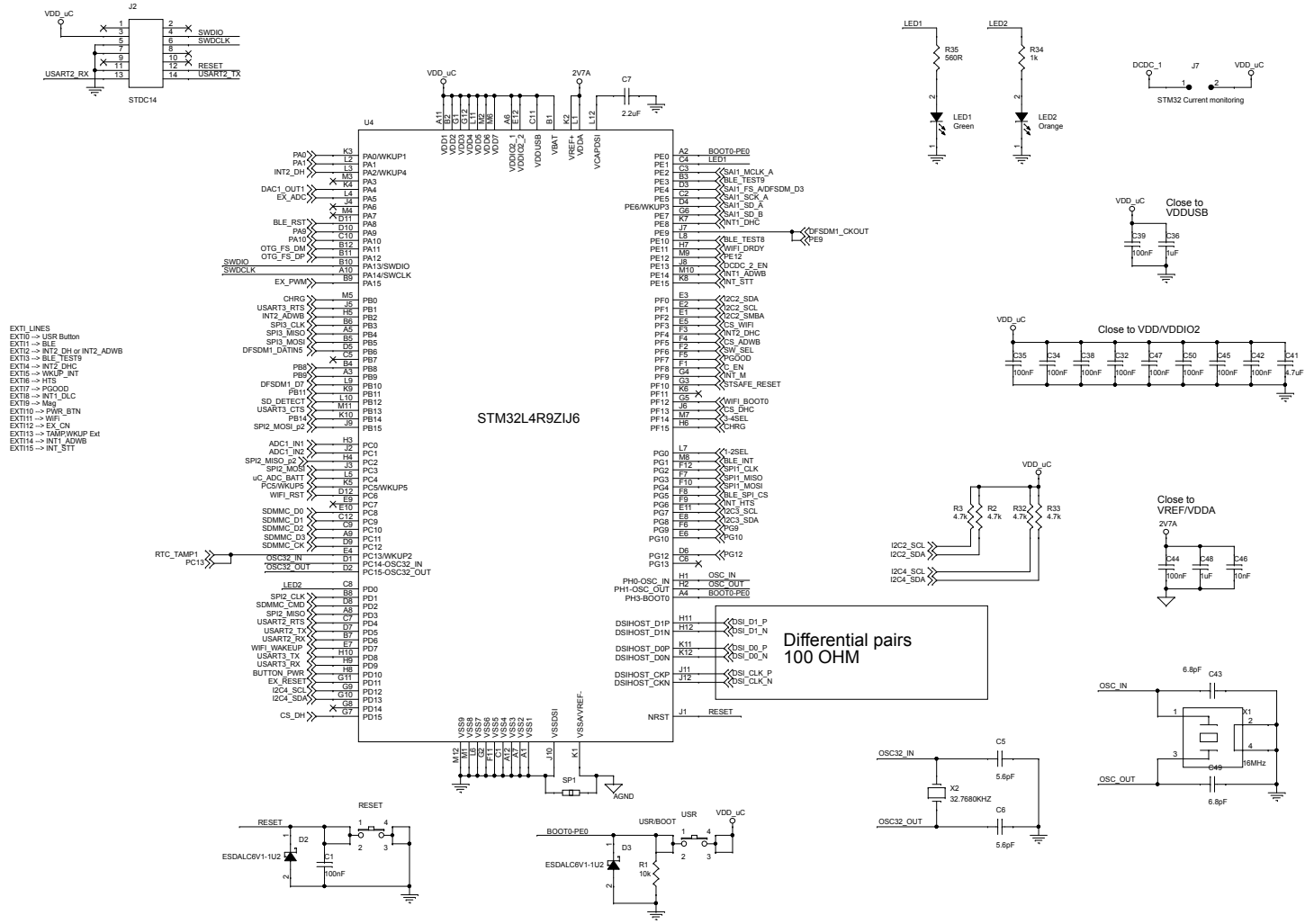

Figure 37. STEVAL-STWINKT1B schematic (5 of 7)

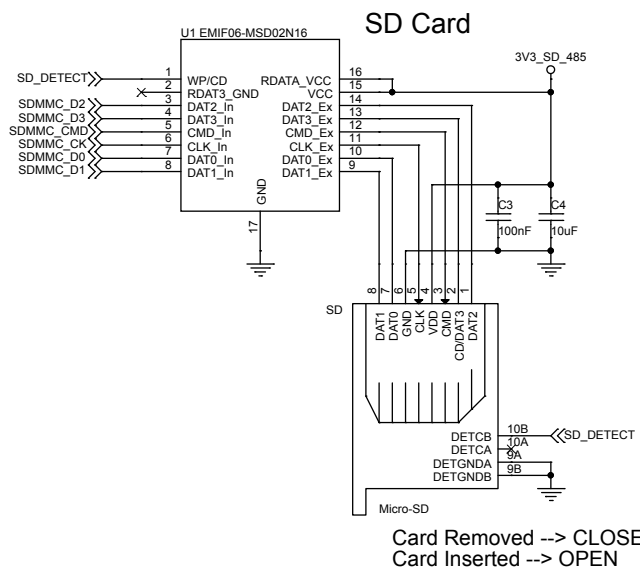
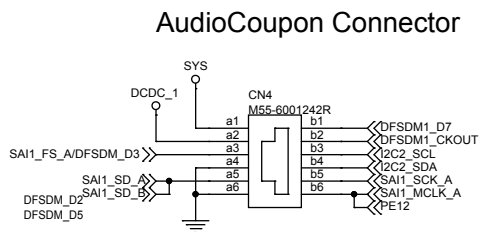
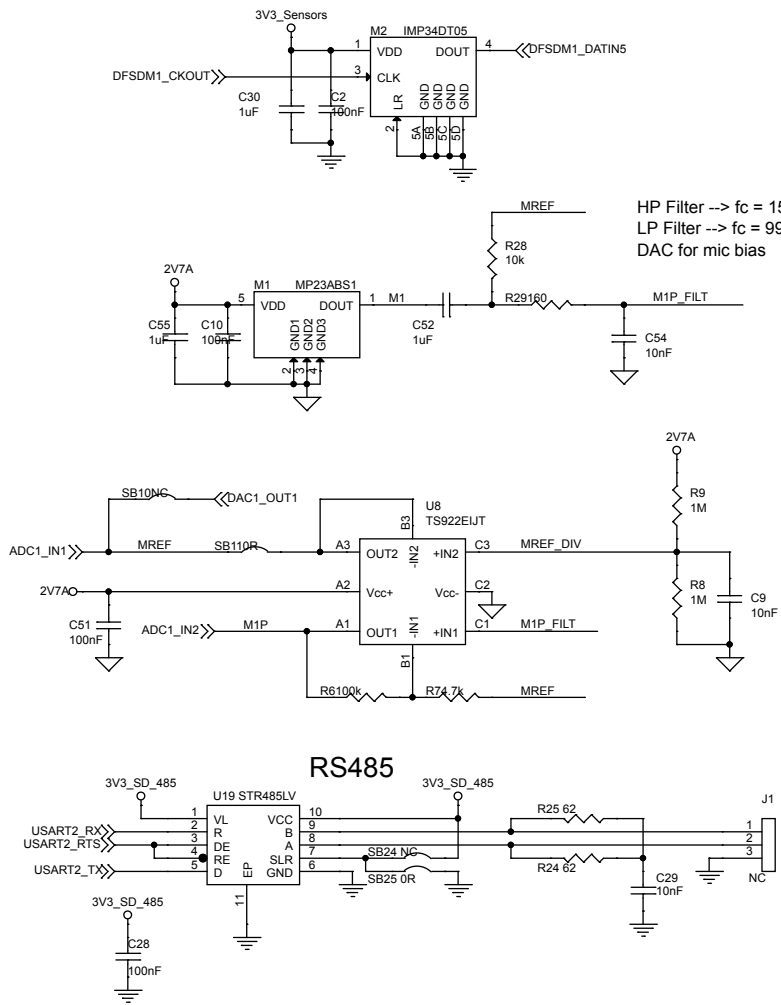



Figure 38. STEVAL-STWINKT1B schematic (6 of 7)

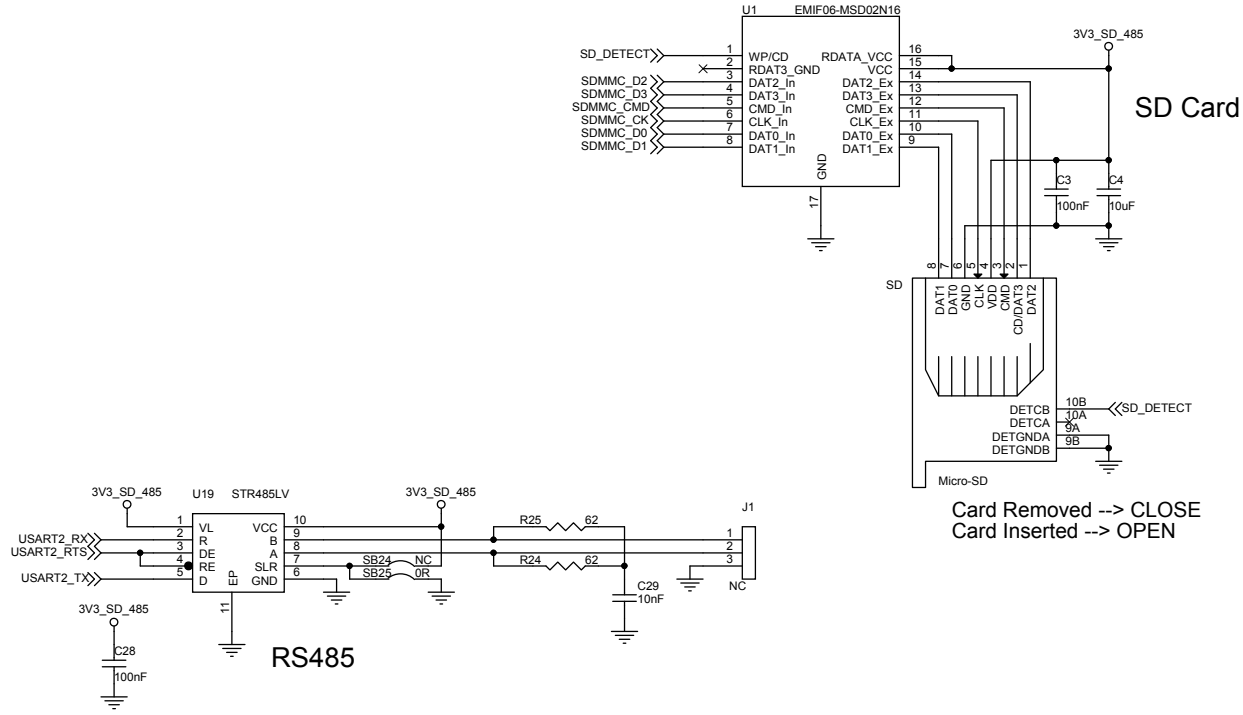
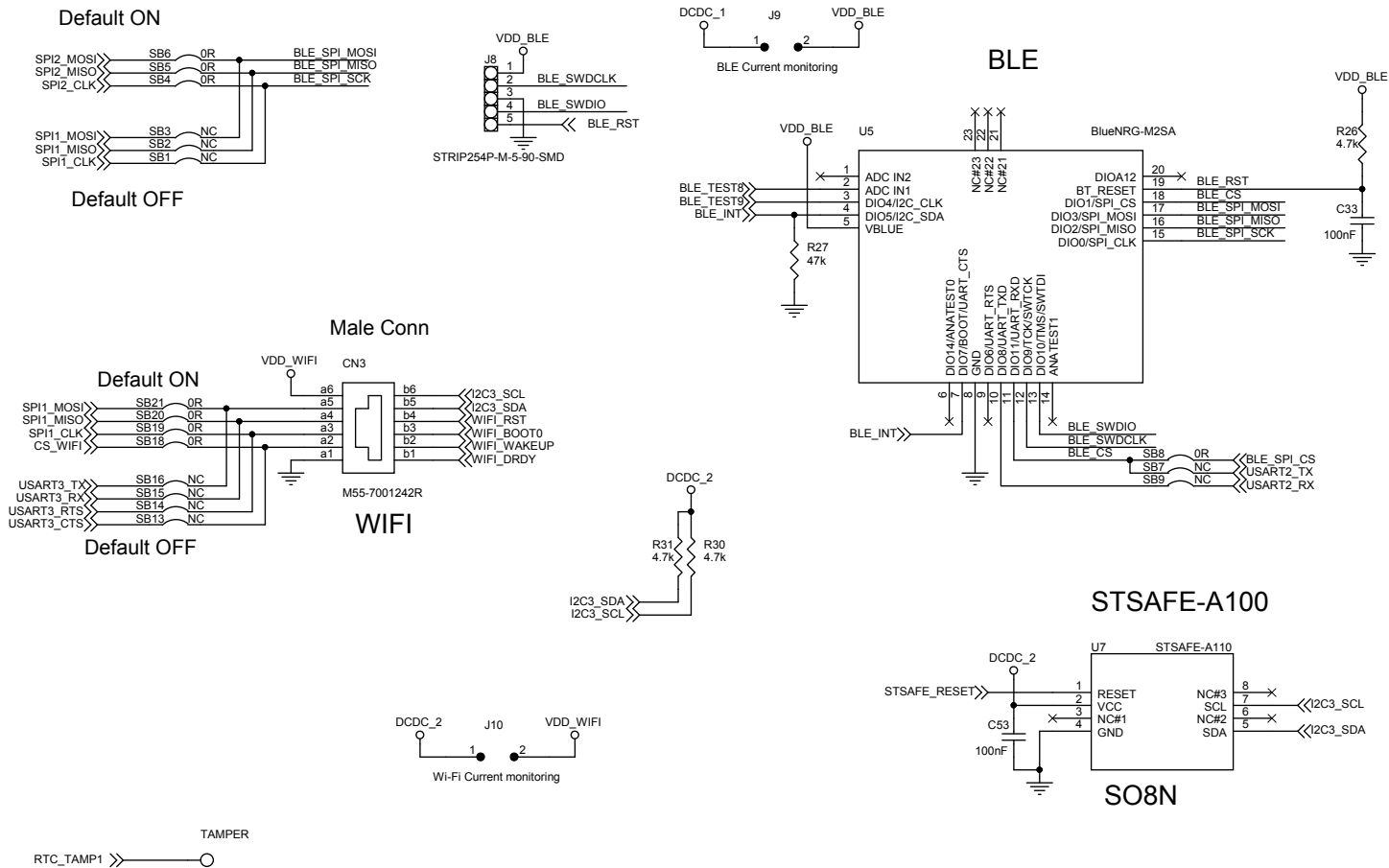

Figure 39. STEVAL-STWINK1B schematic (7 of 7)



## 7 Bill of materials

**Table 5. Bill of materials**

Item	Q.ty	Ref.	Part / Value	Description	Manufacturer	Order code
1	1	BATT		Battery Connector Amass	Molex	78171-0003
2	1	CN1			Hirose	FH34SRJ-40S-0.5SH(99)
3	1	CN2	HEADER 10		Samtec	SQT-110-01-F-D-RA
4	1	CN3		M55 series 12 pin connector, 1.27pitch	Harwin	M55-7001242R
5	1	CN4		M55 series 12 pin connector - Female, 1.27pitch	Harwin	M55-6001242R
6	30	C1, C2, C3, C8, C10, C13, C14, C16, C17, C27, C28, C31, C32, C33, C34, C35, C38, C39, C40, C42, C44, C45, C47, C50, C51, C53, C56, C57, C59, C60	100nF, 16V, ±10%	CAP CER X7R 0402, 0402 (1005 Metric)	Murata Electronics North America	GRM155R71C104KA88J
7	7	C4, C11, C21, C23, C24, C25, C58	10µF, 10V, ±20%	CAP CER X5R 0402, 0402 (1005 Metric)	Samsung Electro-Mechanics America, Inc.	CL05A106MP8NUB8
8	2	C5, C6	5.6pF, 10V, ±1%	CAP CER C0G/NP0 0402, 0402 (1005 Metric)	Yageo	CC0402BRNPO9BN5R6
9	1	C7	2.2µF, 10V, ±20%	CAP CER X5R 0402, 0402 (1005 Metric)	Wurth Electronics Inc.	Wurth-885012105013
10	4	C9, C29, C46, C54	10nF, 25V, ±10%	CAP CER X7R 0402, 0402 (1005 Metric)	AVX Corporation	04023C103KAT2A
11	8	C12, C15, C20, C30, C36, C48, C52, C55	1µF, 10V, ±10%	CAP CER X5R 0402, 0402 (1005 Metric)	Taiyo Yuden	JMK105BJ105KV-F
12	2	C18, C22	22µF, 10V, ±20%	CAP CER X5R 0603, 0603 (1608 Metric)	Taiyo Yuden	LMK107BBJ226MA-T
13	1	C19	0.22µF, 16V, ±10%	CAP CER X7R 0402, 0402 (1005 Metric)	Murata Electronics North America	GRM155R71C224KA12D
14	3	C26, C37, C41	4.7µF, 10V, ±20%	CAP CER X5R 0402, 0402 (1005 Metric)	Murata Electronics North America	GRM155R61A475MEAAD
15	2	C43, C49	6.8pF, 10V, ±5%	CAP CER C0G/NP0 0402, 0402 (1005 Metric)	Murata Electronics North America	GRM0225C1E6R8CA03L
16	3	D1, D2, D3		Single-line low capacitance Transil™ for ESD protection, ST0201	ST	ESDALC6V1-1U2
17	1	D4	1A	Power Schottky rectifier, STmite	ST	STPS120M

Item	Q.ty	Ref.	Part / Value	Description	Manufacturer	Order code
18	1	J1	N.M.	Stripline for RS485 (not mounted)	-	-
19	1	J2	STDC14	STDC14 - ARM MIPI10 compatible	Samtec	FTSH-107-01-L-DV-K
20	1	J3	CON5_1	V_EXT selector	-	-
21	1	J4		STRIP254P-M-2	-	-
22	1	J5	CON2	Morsettiera a 2 vie, passo 2.54mm	-	-
23	1	J6	0 OHM 1206 or 2.54 Jumper	Sensors and digital mic current monitoring: RES SMD	Yageo	AF1206JR-070RL
24	1	J7	0 OHM 1206 or 2.54 Jumper	STM32 Current monitoring: RES SMD	Yageo	AF1206JR-070RL
25	1	J8	N.M.	STRIP254P-M-5-90-SMD (not mounted)	-	-
26	1	J9	0 OHM 1206 or 2.54 Jumper	Bluetooth® low energy current monitoring: RES SMD	Yageo	AF1206JR-070RL
27	1	J10	0 OHM 1206 or 2.54 Jumper	Wi-Fi Current monitoring: RES SMD	Yageo	AF1206JR-070RL
28	1	LED_C	Red	LED, LED_0402	Vishay Semiconductor Opto Division	VLMS1500-GS08
29	1	LED1	Green	LED, LED_0402	Panasonic Electronic Components	LNJ347W83RA
30	1	LED2	Orange	LED, LED_0402	Panasonic Electronic Components	LNJ847W86RA
31	2	L1, L2	2.2uH, ±20%	Inductor, 2520	Würth	Würth-74438323022
32	1	M1	1.3A	MEMS audio sensor	ST	<a href="#">IMP23ABSU</a>
33	1	M2		MEMS audio sensor	ST	<a href="#">IMP34DT05</a>
34	2	USR, PWR	4.2x3.2x2.5mm, white	SW PUSHBUTTON-SPST-2	ALPS	SKRPABE010
35	1	RESET	4.2x3.2x2.5mm, black	SW PUSHBUTTON-SPST-2	ALPS	SKRPAD010
36	1	R1	10k, 100ppm/C, 1/16W, ±1%	RES SMD 0402, 0402 (1005 Metric)	Yageo	RC0402FR-0710KL
37	8	R2, R3, R7, R26, R30, R31, R32, R33	4.7k, 100ppm/C, 1/16W, ±1%	RES SMD 0402, 0402 (1005 Metric)	TE Connectivity Passive Product	CRG0402F4K7
38	2	R4, R5	7.5k, 100ppm/C, 1/16W, ±5%	RES SMD 0402, 0402 (1005 Metric)	Yageo	RC0402JR-077K5L
39	4	R6, R12, R14, R20	100k, 100ppm/C, 1/16W, ±1%	RES SMD 0402, 0402 (1005 Metric)	TE Connectivity Passive Product	CRG0402F100K
40	3	R8, R9, R15	1M, 100ppm/C, ±1%	RES SMD 0402, 0402 (1005 Metric)	TE CONNECTIVITY	CRG0402F1M0
41	1	R10	47.5K, 100ppm/C, 1/16W, ±1%	RES SMD 0402, 0402 (1005 Metric)	Yageo	RC0402FR-0747K5L
42	2	R11, R16	20K, 100ppm/C, 1/16W, ±1%	RES SMD 0402, 0402 (1005 Metric)	Yageo	RC0402FR-0720KL

Item	Q.ty	Ref.	Part / Value	Description	Manufacturer	Order code
43	1	R13	10k N.M., ±1%	RES, SMD, 0402 (not mounted), 0402 (1005 Metric)	TE CONNECTIVITY	CRG0402F10K
44	2	R17, R22	2k, 100ppm/C, ±1%	RES SMD 0402, 0402 (1005 Metric)	Yageo	RT0402FRE072KL
45	1	R18	56K, 100ppm/C, ±1%	RES SMD 0402, 0402 (1005 Metric)	Yageo	RC0402FR-0756KL
46	2	R19, R21	0R	RES SMD 0402, 0402 (1005 Metric)	Vishay Dale	CRCW04020000Z0ED
47	1	R23	100K, 100ppm/C, ±1%	RES SMD 0402, 0402 (1005 Metric)	Yageo	RC0402FR-07100KL
48	2	R24, R25	62, 100ppm/C, 1/16W, ±1%	RES SMD 0402, 0402 (1005 Metric)	Yageo	RC0402FR-0762RL
49	1	R27	47k, 100ppm/C, 1/16W, ±1%	RES SMD 0402, 0402 (1005 Metric)	Samsung Electro-Mechanics America, Inc.	RC1005F473CS
50	1	R28	10k, 100ppm/C, 1/16W, ±1%	RES SMD 0402, 0402 (1005 Metric)	Yageo	RC0402FR-0710KL
51	1	R29	160, 100ppm/C, 1/16W, ±1%	RES SMD 0402, 0402 (1005 Metric)	TE Connectivity Passive Product	CRG0402F160R
52	1	R34	1k, 100ppm/C, 1/16W, ±1%	RES SMD 0402, 0402 (1005 Metric)	Yageo	RC0402FR-071KL
53	1	R35	560R, 100ppm/C, 1/16W, ±1%	RES SMD 0402, 0402 (1005 Metric)	Yageo	RC0402FR-07560RL
54	13	SB1, SB2, SB3, SB7, SB9, SB10, SB13, SB14, SB15, SB16, SB17, SB22, SB24	0 OHM N.M.	RES SMD 0402 (not mounted), 0402 (1005 Metric)	Vishay Dale	CRCW04020000Z0ED
55	12	SB4, SB5, SB6, SB8, SB11, SB12, SB18, SB19, SB20, SB21, SB23, SB25	0R	RES SMD 0402, 0402 (1005 Metric)	Vishay Dale	CRCW04020000Z0ED
56	1	SD		Micro-SD	Wurth Electronics	693071010811
57	1	SP1	N.M.	(not mounted)	-	-
58	7	TP4, TP5, TP6, TP7, TP8, TP9, TAMPER	1mm N.M.	TEST POINT 1MM SMD PADSTASCK (not mounted)	-	-
59	1	TP1		Test Point Through Hole	Keystone Electronics	5001
60	2	TP2, TP3	N.M.	Test Point Through Hole (not mounted)	-	-
61	1	USB		USB Micro-B, USB-Micro-B	GCT	USB3075-30-A
62	1	U1		6-line IPAD™, EMI filter and ESD protection	ST	EMIF06-MSD02N16
63	1	U2		Humidity, Temperature, HLGA-6L(2 x 2 x 0.9 mm)	ST	HTS221TR

Item	Q.ty	Ref.	Part / Value	Description	Manufacturer	Order code
64	1	U3		MEMS NANO PRESSURE SENSOR: 260-1, (2 x 2 x 0.73 mm)	ST	LPS22HHTR
65	1	U4		STM32L496, UFBGA144	ST	STM32L4R9ZIJ6
66	1	U5		Very low power application processor module for Bluetooth® low energy v5.0	ST	BlueNRG-M2SA
67	1	U6		Digital temperature sensor, UDFN-6L	ST	STTS751-0DP3F
68	1	U7		Secure element, SO8N	ST	STSAFE-A110
69	1	U8		OpAmp - excellent audio performance / low distortion (0.005%)	ST	TS922EIJT
70	1	U9		3D accelerometer and 3D gyroscope, LGA-14L (2.5 x 3 x 0.83 mm)	ST	ISM330DHCX
71	1	U10		300 mA Very low noise LDO, DFN6	ST	LDK130PU-R
72	1	U11		Accelerometer Ultra Wide Bandwidth, LGA-14L (2.5 x 3 x 0.83 mm)	ST	IIS3DWB
73	1	U12		Accelerometer Ultra-low-power, LGA-12 (2.0x2.0x1 mm)	ST	IIS2DHTR
74	1	U13		MEMS Magnetometer, (2.0x2.0x0.7)	ST	IIS2MDCTR
75	2	U14, U16		400mA step-down switching regulator, Flip-chip	ST	ST1PS01EJR
76	1	U15		Li-Ion Linear Battery Charger with LDO 3.3V, Flip Chip30 (2.59x2.25 mm)	ST	STBC02AJR
77	1	U17		Low voltage high bandwidth quad SPDT switch	ST	STG3692
78	1	U18		USB Protection	ST	USBLC6-2P6
79	1	U19		Low power transceiver for RS-485, DFN10	ST	STR485LV
80	1	X1	16MHz	16.00MHz Crystal 8pF	NDK	NX3225GA-16MHZ-STD-CRG-1
81	1	X2	32.7680KHZ	CRYSTAL 32.7680KHz 6PF SMD	NDK	NX3215SA-32.768K-STD-MUA-14
82	1			STLINK-V3MINI	ST	STLINK-V3MINI
83	1			Programming Cable (Included in ST-LINK)	-	-
84	1			Plastic Box	-	-
85	1		480mAh	Battery LiPo	Himax	LiPo-752535

Item	Q.ty	Ref.	Part / Value	Description	Manufacturer	Order code
86	4		12mm M3	Pan head phillips - steel	-	-
87	4		M3	HEX Nut - steel	-	-

## Revision history

**Table 6. Document revision history**

Date	Version	Changes
17-Nov-2020	1	Initial release.
11-Jan-2021	2	Updated Introduction. Minor text changes.
10-Jun-2021	3	Updated Section 2.1 Sensing, Section 2.2 Processing and connectivity, Section 2.3 Power management, Section 2.3.4 Power consumption evaluation and Section 2.4 Buttons, LEDs and connectors.



## Contents

<b>1</b>	<b>STWIN kit components</b>	<b>2</b>
<b>2</b>	<b>Functional blocks</b>	<b>4</b>
<b>2.1</b>	<b>Sensing</b>	<b>4</b>
<b>2.1.1</b>	HTS221 humidity and temperature sensor	5
<b>2.1.2</b>	LPS22HH MEMS pressure sensor	5
<b>2.1.3</b>	STTS751 digital temperature sensor	6
<b>2.1.4</b>	TS922 rail-to-rail, high output current, dual operational amplifier	6
<b>2.1.5</b>	ISM330DHCX iNEMO IMU 3D Acc + 3D Gyro	6
<b>2.1.6</b>	IIS3DWB ultra-wide bandwidth (up to 6 kHz), low-noise, 3-axis digital vibration sensor	6
<b>2.1.7</b>	IIS2DH ultra-low power 3-axis high-performance accelerometer	6
<b>2.1.8</b>	IIS2MDC 3-axis magnetometer	7
<b>2.1.9</b>	IMP23ABSU analog MEMS microphone with extended frequency response up to 80 kHz for ultrasound applications	7
<b>2.1.10</b>	IMP34DT05 digital MEMS microphone	7
<b>2.2</b>	<b>Processing and connectivity</b>	<b>7</b>
<b>2.2.1</b>	STM32L4R9ZI Cortex-M4F 120MHz 640Kb RAM	9
<b>2.2.2</b>	BlueNRG-M2 very low power application processor module for Bluetooth® low energy v5.0	10
<b>2.2.3</b>	STEVAL-STWINWV1 Wi-Fi expansion (not included in the kit) for the SensorTile wireless industrial node (STWIN) kit	10
<b>2.2.4</b>	STR485LV 3.3V RS485 up to 20Mbps	10
<b>2.2.5</b>	USB connector	11
<b>2.2.6</b>	STSAFE-A110 authentication, state-of-the-art security for peripherals and IoT devices	11
<b>2.2.7</b>	microSD card socket	11
<b>2.2.8</b>	Clock sources	11
<b>2.3</b>	<b>Power management</b>	<b>11</b>
<b>2.3.1</b>	Battery connectors	13
<b>2.3.2</b>	Power supply	13
<b>2.3.3</b>	Power ON/OFF procedure	14
<b>2.3.4</b>	Power consumption evaluation	14
<b>2.4</b>	<b>Buttons, LEDs and connectors</b>	<b>15</b>
<b>2.4.1</b>	Flex expansion connector	15

---

2.4.2	STMod+ connector .....	17
2.4.3	Connectivity expansion connector .....	18
2.4.4	Sensor expansion connector .....	18
2.5	Protective plastic box .....	19
2.6	STLINK-V3MINI debugger and programmer for STM32 .....	19
<b>3</b>	<b>How to program the board .....</b>	<b>20</b>
3.1	How to program STWIN with STLINK-V3MINI .....	20
3.2	How to program STWIN without STLINK-V3MINI using STM32CubeProgrammer "USB mode" .....	20
<b>4</b>	<b>STWIN assembly steps .....</b>	<b>23</b>
<b>5</b>	<b>How to run the HSDatalog application .....</b>	<b>26</b>
<b>6</b>	<b>Schematic diagrams .....</b>	<b>28</b>
<b>7</b>	<b>Bill of materials .....</b>	<b>35</b>
	<b>Revision history .....</b>	<b>40</b>

## List of figures

<b>Figure 1.</b>	STEVAL-STWINKT1B SensorTile Wireless Industrial Node . . . . .	1
<b>Figure 2.</b>	STWIN Core System board top and bottom . . . . .	2
<b>Figure 3.</b>	Protective plastic case . . . . .	2
<b>Figure 4.</b>	480mAh 3.7V Li-Po Battery . . . . .	2
<b>Figure 5.</b>	STLink-V3Mini Debugger/Programmer for STM32. . . . .	3
<b>Figure 6.</b>	Programming cable . . . . .	3
<b>Figure 7.</b>	STEVAL-STWINKT1B functional block diagram . . . . .	4
<b>Figure 8.</b>	STEVAL-STWINKT1B functional block diagram of sensing elements and STM32L4R9ZI6 . . . . .	4
<b>Figure 9.</b>	Core system board sensor locations . . . . .	5
<b>Figure 10.</b>	Main connectivity components and the STM32L4R9ZI processing unit. . . . .	8
<b>Figure 11.</b>	MCU and connectivity element locations . . . . .	9
<b>Figure 12.</b>	Power and protection components . . . . .	12
<b>Figure 13.</b>	Power and protection component locations . . . . .	12
<b>Figure 14.</b>	Battery and J4 connectors for VBAT supply . . . . .	13
<b>Figure 15.</b>	Power circuits. . . . .	13
<b>Figure 16.</b>	Power monitoring points . . . . .	14
<b>Figure 17.</b>	Buttons, LEDs and connectors . . . . .	15
<b>Figure 18.</b>	CN1 Flex connector top view . . . . .	15
<b>Figure 19.</b>	STMod+ connector top views . . . . .	17
<b>Figure 20.</b>	CN3 connectivity connector top view . . . . .	18
<b>Figure 21.</b>	CN4 sensor connector top view . . . . .	18
<b>Figure 22.</b>	STLINK-V3MINI and STDC14 cable . . . . .	19
<b>Figure 23.</b>	STLINK-V3MINI connected to STWIN core system board. . . . .	20
<b>Figure 24.</b>	STM32CubeProgrammer - USB mode selection . . . . .	21
<b>Figure 25.</b>	STM32CubeProgrammer - connection. . . . .	22
<b>Figure 26.</b>	STM32CubeProgrammer - programming . . . . .	22
<b>Figure 27.</b>	Exploded cad drawing of STWIN node components . . . . .	23
<b>Figure 28.</b>	Optional magnets inserted in main case. . . . .	24
<b>Figure 29.</b>	Core system board inserted in main case. . . . .	24
<b>Figure 30.</b>	Core system board fastened with bolts . . . . .	25
<b>Figure 31.</b>	HSDatalog data flow . . . . .	26
<b>Figure 32.</b>	Folder structure in the SD card . . . . .	27
<b>Figure 33.</b>	STEVAL-STWINKT1B schematic (1 of 7) . . . . .	28
<b>Figure 34.</b>	STEVAL-STWINKT1B schematic (2 of 7) . . . . .	29
<b>Figure 35.</b>	STEVAL-STWINKT1B schematic (3 of 7) . . . . .	30
<b>Figure 36.</b>	STEVAL-STWINKT1B schematic (4 of 7) . . . . .	31
<b>Figure 37.</b>	STEVAL-STWINKT1B schematic (5 of 7) . . . . .	32
<b>Figure 38.</b>	STEVAL-STWINKT1B schematic (6 of 7) . . . . .	33
<b>Figure 39.</b>	STEVAL-STWINKT1B schematic (7 of 7) . . . . .	34

## List of tables

<b>Table 1.</b>	CN1 pin descriptions . . . . .	15
<b>Table 2.</b>	STMod+ connector pin assignments and descriptions. . . . .	17
<b>Table 3.</b>	CN3 pin descriptions . . . . .	18
<b>Table 4.</b>	CN4 pin descriptions . . . . .	19
<b>Table 5.</b>	Bill of materials . . . . .	35
<b>Table 6.</b>	Document revision history . . . . .	40

**IMPORTANT NOTICE – PLEASE READ CAREFULLY**

STMicroelectronics NV and its subsidiaries (“ST”) reserve the right to make changes, corrections, enhancements, modifications, and improvements to ST products and/or to this document at any time without notice. Purchasers should obtain the latest relevant information on ST products before placing orders. ST products are sold pursuant to ST’s terms and conditions of sale in place at the time of order acknowledgement.

Purchasers are solely responsible for the choice, selection, and use of ST products and ST assumes no liability for application assistance or the design of Purchasers’ products.

No license, express or implied, to any intellectual property right is granted by ST herein.

Resale of ST products with provisions different from the information set forth herein shall void any warranty granted by ST for such product.

ST and the ST logo are trademarks of ST. For additional information about ST trademarks, please refer to [www.st.com/trademarks](http://www.st.com/trademarks). All other product or service names are the property of their respective owners.

Information in this document supersedes and replaces information previously supplied in any prior versions of this document.

© 2021 STMicroelectronics – All rights reserved