

# TB62D901FNG

## AC/DC Step-Down Conversion Type LED Lighting Driver

### 1. General

The TB62D901FNG is a constant current driver IC ideal for use in the step-down AC/DC conversion type LED lighting applications.

The TB62D901FNG features architecture with automatic Off time adjustment control that can be used to achieve minimum LED current variations by the effect of fluctuated input voltage or change of LED forward voltage.

The device allows linear dimming or PWM dimming. It has extensive detection functions that are thermal shutdown, over-current detection, over-voltage detection, under-voltage lockout, and current sensing input terminal (ISEN1) open detection.

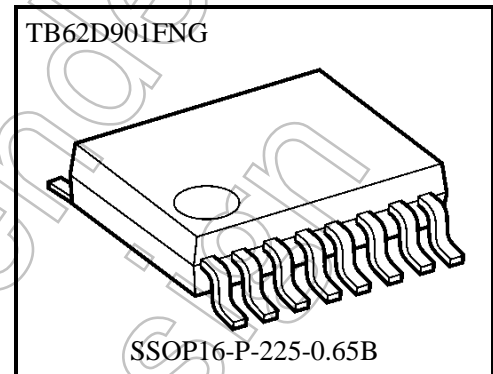

Weight: 0.07 g (typ.)

### 2. Application

LED lighting

### 3. Features

- Operating supply voltage : 12V to 30V
- Dimming function : Linear dimming (by adjustment of LED peak current)  
PWM dimming
- Switching frequency : Adjustable of up to 500kHz (MAX)
- Operation mode : Current continuous conduction mode  
(Automatic OFF time control mode, Fixed off time mode)  
Critical conduction mode
- Efficiency : 90% or more with recommended components
- Detection function : Thermal shutdown (TSD)  
: Over-current detection (OCP)  
: Over-voltage detection (OVP)  
: Under-voltage lockout (UVLO)  
: ISEN terminal open detection (IOP)
- IC standby function : EN signal allows standby mode with 0.8mA (MAX) consumption current
- Operating temperature :  $T_{opr} = -40\text{ }^{\circ}\text{C}$  to  $105\text{ }^{\circ}\text{C}$
- Package : SSOP16-P-225-0.65B

**4. Block Diagram**

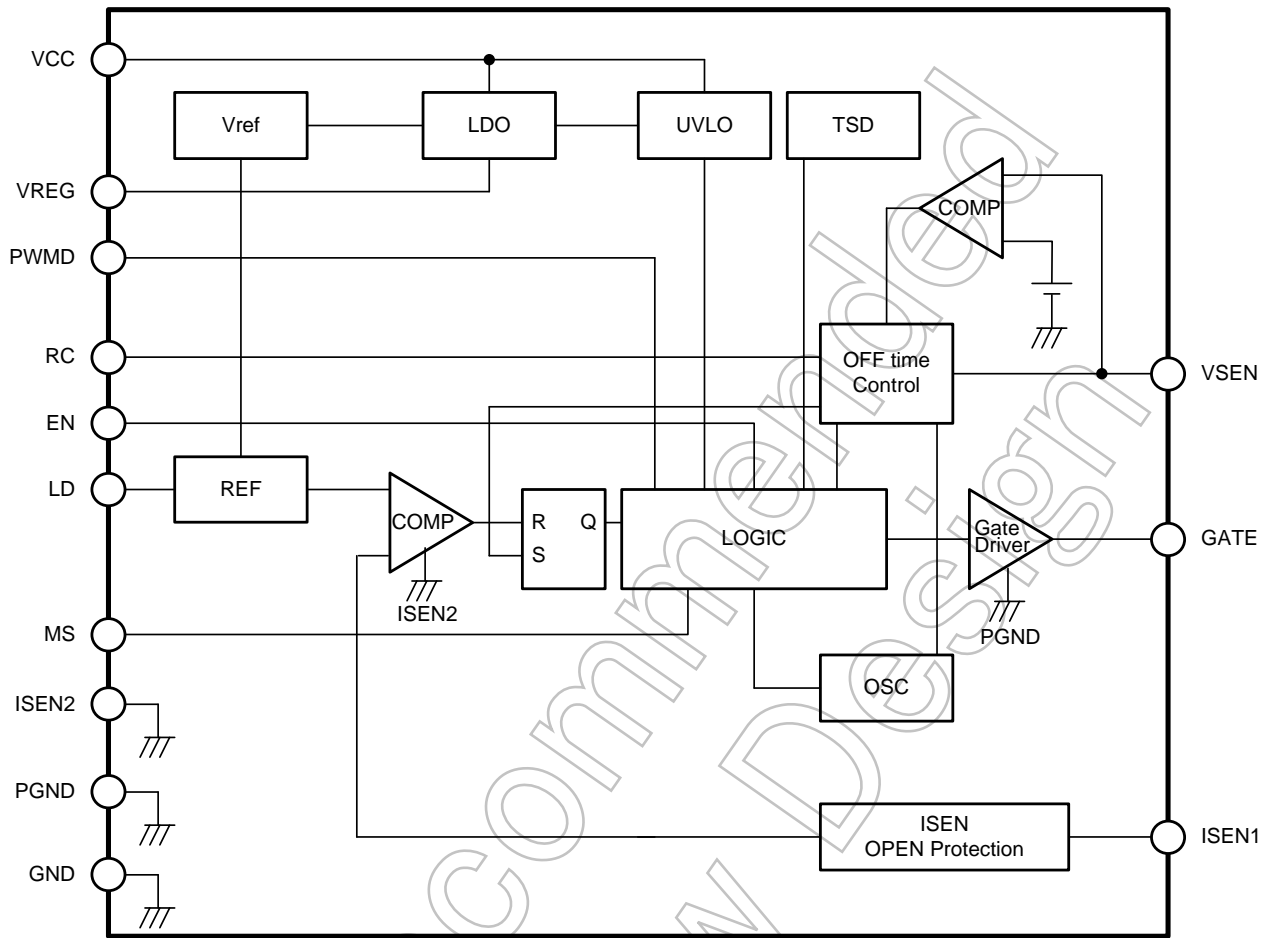

Not Recommended for New

**5. Pin Assignment (top view)**

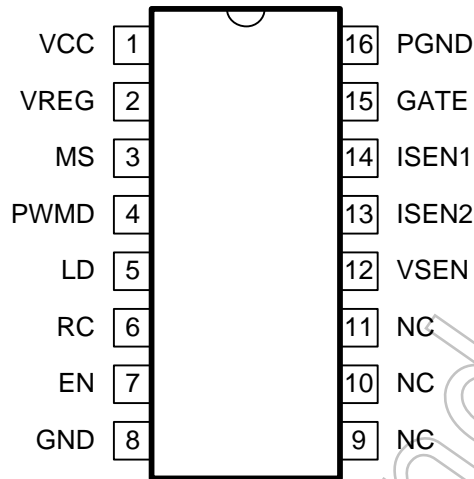

**6. Pin Description**

Pin No	Pin Name	I/O	Function
1	VCC	P	Power supply input.
2	VREG	O	Output of the internal regulator.
3	MS	I	Input to set switching operation mode. GND short-circuit: Continuous mode VREG terminal short-circuit: Critical mode
4	PWMD	I	PWM signal input for the PWM dimming. "H" level voltage input: LED lighting current on "L" level voltage input: LED lighting current off
5	LD	I	Analogue input voltage to set the peak value of the LED current.
6	RC	I	Analog input to set the ripple range of the LED current.
7	EN	I	IC enable signal input. "H" level voltage input: Operation mode "L" level voltage input: Standby mode. In standby mode, circuits other than the regulator circuit, the standard voltage circuit, and the UVLO circuit stop operation.
8	GND	P	Ground.
9	NC	-	No Connect. Connect to GND
10	NC	-	No Connect. Connect to GND
11	NC	-	No Connect. Connect to GND
12	VSEN	I	Input for feedback voltage. This input voltage of VSEN determines the OFF time of the control output GATE for external power MOSFET of the step-down driver.
13	ISEN2	I	Detection terminal for LED current. Connect to the GND side of the current sensing resistor between ISEN1 and GND.
14	ISEN1	I	Detection terminal for LED current. The peak value of LED current is determined by the resistance connected between ISEN1 terminal and GND.
15	GATE	O	Output for controlling the Gate of the Power MOSFET
16	PGND	P	Power ground for GATE diver.

\*I/O symbol I: Input, O: Output, P: Power supply

**7. I/O Equivalent Circuits**

Pin No	Pin Name	Equivalent circuit	Pin No	Pin Name	Equivalent circuit
1	VCC		8	GND	
2	VREG		13	PGND	
3	MS		16	ISEN2	
5	LD		12	VSEN	
6	RC		14	ISEN1	
4	PWMD		15	GATE	
7	EN				

8. Absolute Maximum Ratings ( $T_a = 25^\circ\text{C}$ )

Characteristics	Symbol	Rating Note1	Unit
Supply voltage	$V_{CC}$	-0.3 to 40	V
Input pin voltage (PWMD, LD, RC, EN, and MS)	$V_{IN}$	-0.3 to 6.0	V
VREG pin voltage	$V_{REG}$	-0.3 to 6.0	V
Feedback pin voltage (ISEN1 and VSEN)	$V_{FB}$	-0.3 to 6.0	V
GATE pin voltage	$V_{GATE}$	-0.3 to $V_{CC}$	V
Operating temperature	$T_{opr}$	-40 to 105	$^\circ\text{C}$
Storage temperature	$T_{stg}$	-55 to 150	$^\circ\text{C}$
Thermal resistance	$R_{th(j-a)}$	87.3* Note 2	$^\circ\text{C}/\text{W}$
Power dissipation	$P_D$	1.43* Note2,3	W

Note1: Voltage is PGND/GND/ISEN2 referenced.

Note2: PCB condition is 76.2×114.3×1.6mm (JEDEC 4 layer substrate)

Note3: When ambient temperature is 25 $^\circ\text{C}$  or more. Every time ambient temperature exceeded 1 $^\circ\text{C}$ , please decrease 1/ $R_{th(j-a)}$ .

9. Operating Condition (Unless otherwise noted,  $T_a = -40$  to 105  $^\circ\text{C}$ )

Characteristics	Symbol	Test Conditions	Min	Typ.	Max	Unit
Operating supply voltage	$V_{CC}$		12	—	30	V
Switching frequency	$f_{SW}$		—	—	500	kHz
LD pin input voltage	$V_{LD1}$	When LED peak current adjustment function is used	0.2	—	3.8	V
	$V_{LD2}$	When LED peak current adjustment function is not used	4.5	—	$V_{REG}$	
RC pin input voltage	$V_{RC1}$	When LED peak current adjustment function is used	1	—	4.0	V
	$V_{RC2}$	When LED peak current adjustment function is not used	0	—	0.5	
VSEN pin input voltage	$V_{VSEN1}$	When using it in automatic OFF time control mode	0.5	—	3	V
	$V_{VSEN2}$	When using it in Fixed OFF time mode	4.5	—	$V_{REG}$	

GATE pin output voltage which is the same level as  $V_{CC}$ . Please set up  $V_{CC}$  in consideration of the Absolute Maximum Ratings of the external power MOSFET

**10. Electrical Characteristics (Unless otherwise noted, T<sub>a</sub> = 25 °C, V<sub>CC</sub>=12V)**

Characteristics	Symbol	Test Conditions	Min	Typ.	Max	Unit
<b>&lt;Consumption current&gt;</b>						
Operating consumption current	I <sub>CC(ON)</sub>	EN=H, PWMD=H, MS=L V <sub>VSEN</sub> =V <sub>REG</sub> , V <sub>LD</sub> =V <sub>REG</sub> , V <sub>RC</sub> =0V V <sub>ISEN1</sub> =0V	—	2.0	2.5	mA
Standby consumption current	I <sub>CC(OFF)</sub>	EN=L	—	0.5	0.8	
<b>&lt;Regulator part&gt;</b>						
VREG output voltage	V <sub>REG</sub>	I <sub>REG</sub> =0mA	4.9	5	5.1	V
VREG maximum output current	I <sub>REG</sub>		—	—	2	mA
<b>&lt;UVLO part&gt;</b>						
UVLO release voltage	V <sub>UVLO(UP)</sub>	V <sub>CC</sub> rising	10.5	11	11.5	V
UVLO operation voltage	V <sub>UVLO(DOWN)</sub>	V <sub>CC</sub> falling	8.0	8.5	9.0	V
<b>&lt;GATE Driver part&gt;</b>						
GATE pin source resistance	R <sub>GATEH</sub>	I <sub>GATE</sub> =-100mA	—	5	10	Ω
GATE pin sink resistance	R <sub>GATEL</sub>	I <sub>GATE</sub> =100mA	—	2.5	5	Ω
GATE pin rising time	t <sub>rGATE</sub>	C <sub>L</sub> =1nF	—	15	30	ns
GATE pin falling time	t <sub>fGATE</sub>	C <sub>L</sub> =1nF	—	15	30	ns
MOSFET OFF time	t <sub>OFF</sub>	EN=H, PWMD=H, MS=L V <sub>VSEN</sub> =V <sub>REG</sub> , V <sub>LD</sub> =V <sub>REG</sub> , V <sub>RC</sub> =0V	3.87	4	4.13	μs
<b>&lt;Detection circuit part&gt;</b>						
OVP operation voltage	V <sub>OVP</sub>	V <sub>CC</sub> pin	32	35	38	V
OCP operation voltage	V <sub>OCP1</sub>	ISEN pin, V <sub>LD</sub> =V <sub>REG</sub>	1.4	1.6	1.8	V
	V <sub>OCP2</sub>	ISEN pin, V <sub>LD</sub> =0.2V	V <sub>LD</sub> +0.1	V <sub>LD</sub> +0.4	V <sub>LD</sub> +0.7	
	V <sub>OCP3</sub>	ISEN pin, V <sub>LD</sub> =3.8V	V <sub>LD</sub> -0.0	V <sub>LD</sub> +0.2	V <sub>LD</sub> +0.4	
TSD operation temperature	T <sub>TSD</sub>	Temperature rising	130	140	150	°C
TSD hysteresis temperature	T <sub>TSD(HYS)</sub>	Temperature falling	10	20	30	°C
<b>&lt;Input pin part&gt;</b>						
Input pin high level input voltage (PWMD, EN, and MS)	V <sub>INH</sub>		1.5	—	V <sub>REG</sub>	V
Input pin Low level input voltage (PWMD, EN, and MS)	V <sub>INL</sub>		0	—	0.4	V
Input pin input current	I <sub>INH</sub>	Measurement pin is PWMD, EN, LD, and RC. V <sub>IN</sub> =V <sub>REG</sub> , V <sub>ISEN1</sub> =0V	—	—	1	μA
	I <sub>INL</sub>	Measurement pin is PWMD, EN, MS, LD, and RC. V <sub>IN</sub> =0V, V <sub>ISEN1</sub> =0V	-1	—	—	μA
MS pin pull down resistance	R <sub>LUP</sub>		240	300	360	kΩ
<b>&lt;Detection pin part&gt;</b>						
ISEN pin peak voltage	V <sub>PEAK1</sub>	V <sub>LD</sub> =V <sub>REG</sub>	0.95	1.0	1.05	V
	V <sub>PEAK2</sub>	V <sub>LD</sub> =0.2V to 3.8V	V <sub>LD</sub> /1.5-0.1	V <sub>LD</sub> /1.5	V <sub>LD</sub> /1.5+0.1	
Detection blanking time	t <sub>BLK</sub>		250	400	550	ns

**11. Description of Operation**

11.1 Standard connection diagram

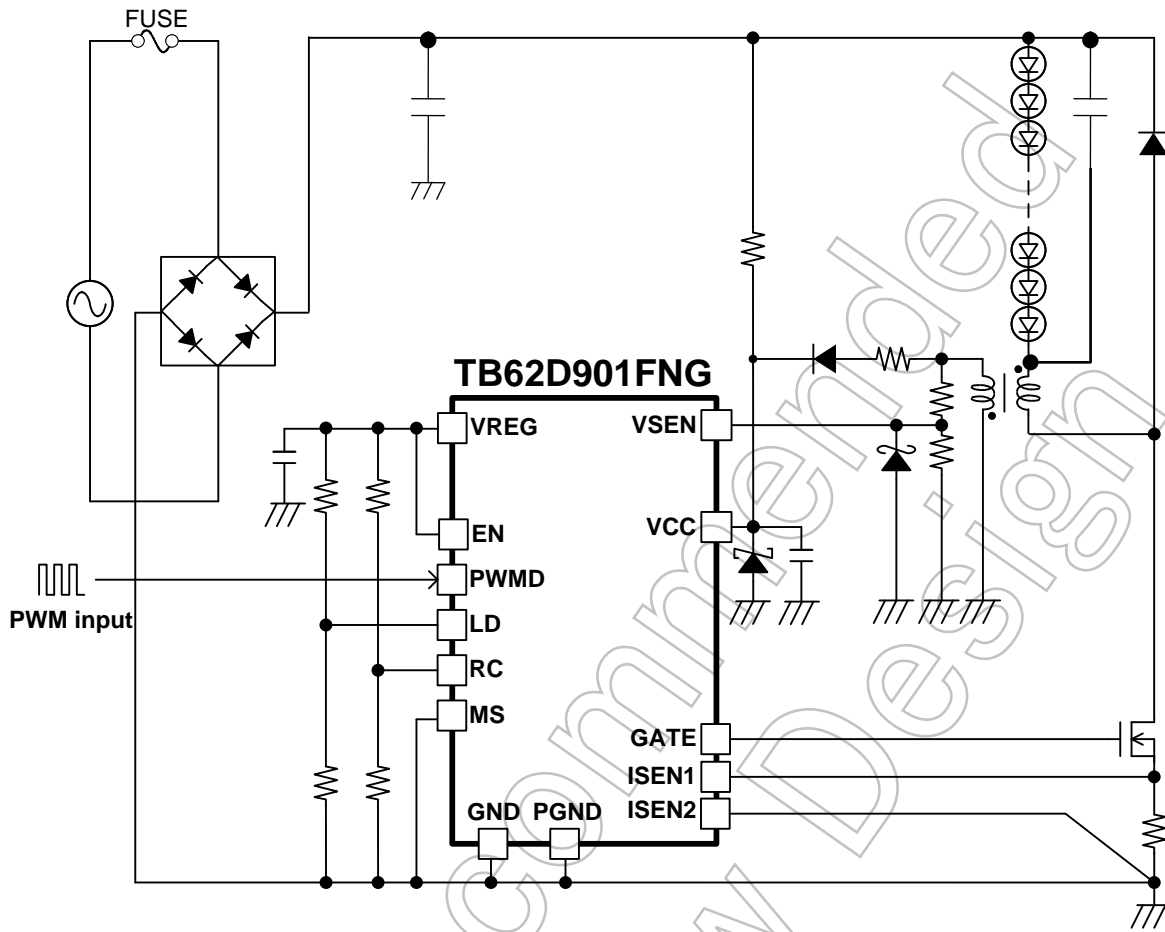

Not Recommended for New

11.2 Operation modes

There are three operation modes, and the modes are set by pins MS and VSEN. Each mode has the different control method resulting in the different GATE output to the external power MOSFET.

Table 1 Operation Mode Comparison

Operation mode		Pin Settings		Output of GATE to Control the Power MOS (M1)	
		MS 1	VSEN	OFF time	On time
1	Fixed OFF time mode	GND	VREG	It is fixed at 4μs (TYP). (when V <sub>RC</sub> =0V)	It is determined by voltage detection in ISEN1 pin
2	Automatic OFF time control mode	GND	Connected to the secondary side of the transformer	It is determined by voltage detection in VSEN pin	It is determined by voltage detection in ISEN1 pin
3	Critical mode	VREG	Connected to the secondary side of the transformer	It is determined by detecting 0 mA of LED current in VSEN pin	It is determined by voltage detection in ISEN1 pin

11.2.1 Fixed Off time mode

LED current  $I_{LED}$  in path A is detected as the voltage on the current-sense resistor RSET on the ISEN1 input. When  $I_{LED}$  rises to the set peak current  $I_{LEDP}$ , M1 is turned off. And M1 is turned on again after turned off a period of time, for example, 4 μs (Typ.) when  $V_{RC}$  is 0 V. The peak current can be set with the input voltage to LD pin. (Please refer to 12.2, Figure for details). The off period can be set by an applied voltage to the RC pin. (Please refer to 12.3, Figure for details).

$V_{IN}$  of the LEDs is referred to the unregulated diode bridge rectified DC voltage that can fluctuate considerably. The influence of the input voltage ( $V_{IN}$ ) change on the LED current can be reduced to the minimum by this control system. This mode can be implemented with fewer components.

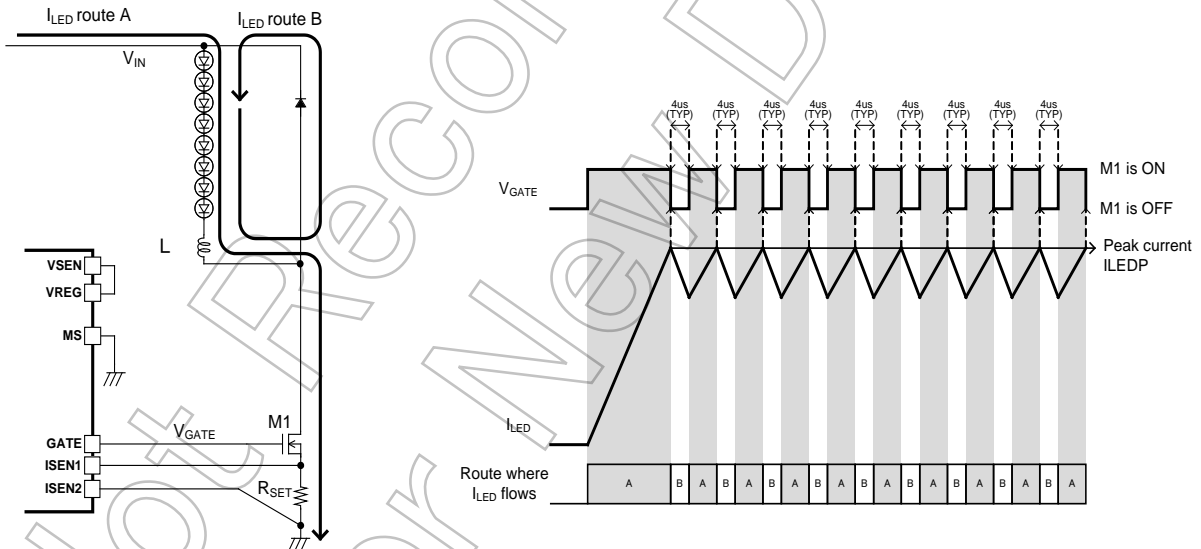

Figure 1. Fixed Off-Time Control



11.2.2 Automatic OFF Time Control Mode

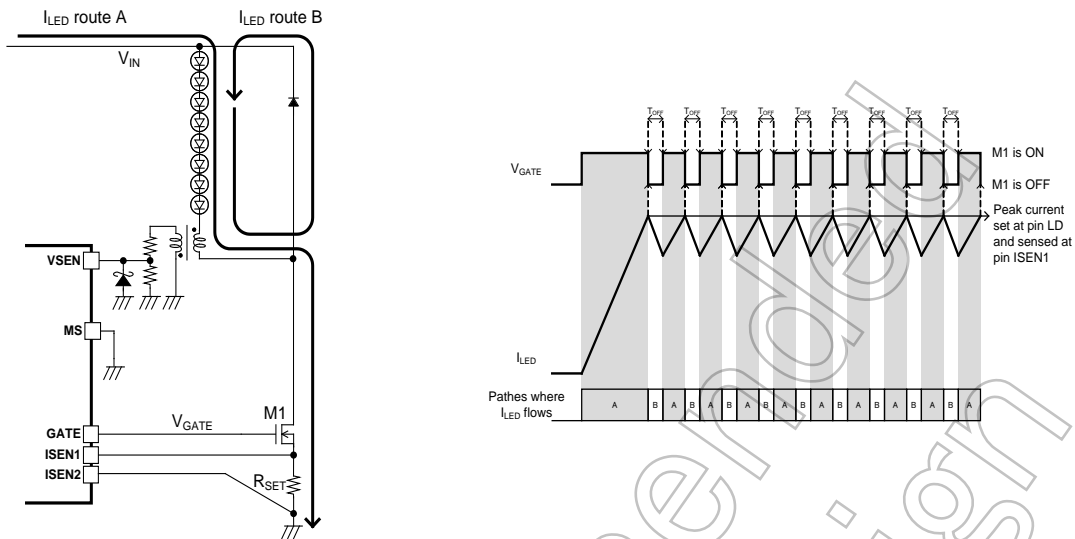

Figure 2 Automatic Off-Time Control

When LED current  $I_{LED}$  in path A, which is detected at the ISEN1 pin, rises to the set peak current, M1 is turned off. And M1 is turned on again after the OFF period of M1 ( $t_{OFF}$ ) (refer to Figure 2).

The peak current is set by an applied voltage to the LD pin. (Please refer to 12.2 for details).

$t_{OFF}$  is determined by the voltage on inputs VSEN and RC. (Please refer to 12.3, Figure 3 and 8 for details.). In the example of Figure 2, the voltage at VSEN pin is generated by the secondary side of the transformer and the input voltage of RC pin.

Secondary side voltage is stabilized by total  $V_f$  of LED.

It is recommended that the voltage generated on the secondary side is divided by resistors and to keep the voltage applied to VSEN pin at around 1V. The Off time of M1 is adjusted automatically when  $V_f$  of the LED and the free wheeling diode are changed due to the temperature characteristics and the change of the voltage applied to VSEN pin (compared to 1 V) is detected.

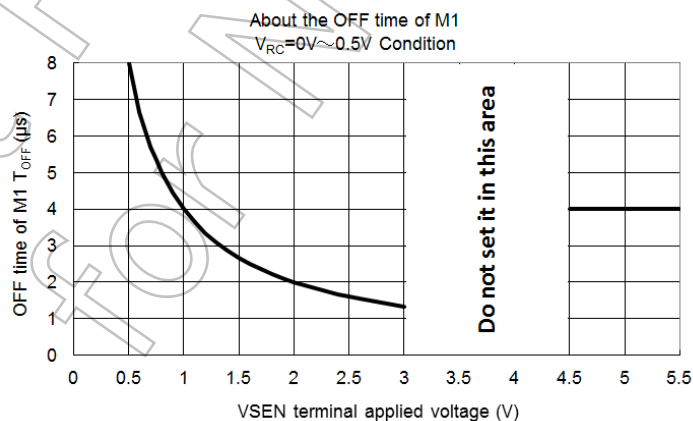

Figure 3. OFF time vs. VSEN when  $V_{RC} < 0.5V$

Please use the IC by inputting a voltage to the VSEN pin in the range of 0.5V to 3.0V or 4.5V to  $V_{REG}$ . In this mode, the dependence of the LED current on the input voltage  $V_{IN}$  and  $V_f$  are reduced.

11.2.3 Critical mode

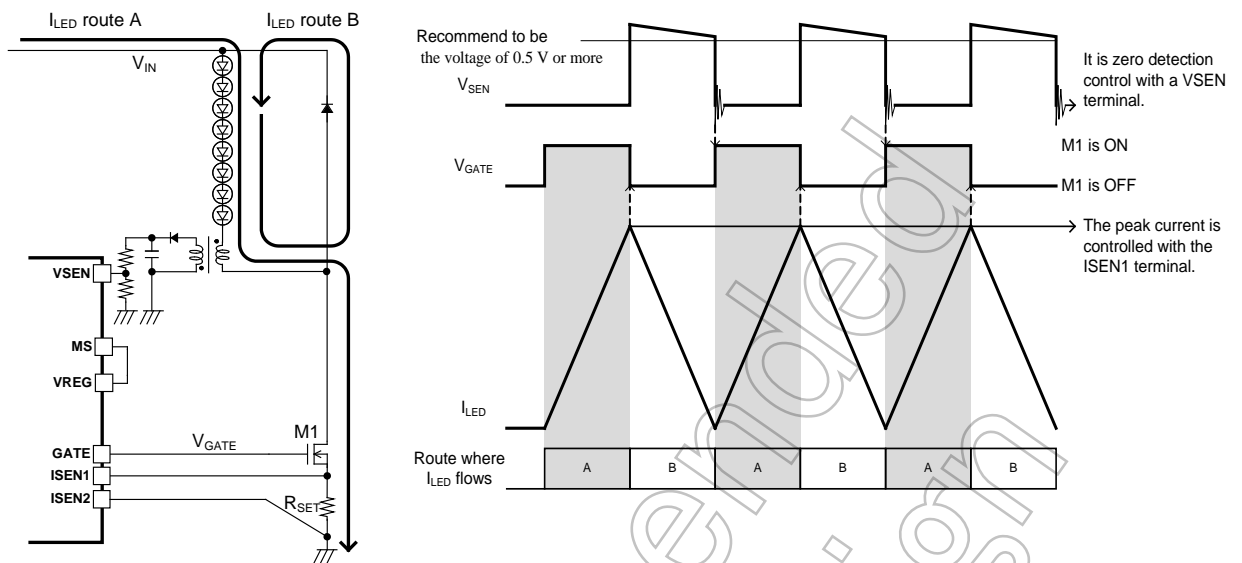

Figure 4 Critical Conduction Mode

When  $I_{LED}$  in path A detected with the ISEN1 pin rises to the set peak current, M1 is turned off. And M1 is turned on again when VSEN pin, connected to the secondary side of the transformer, detects that  $I_{LED}$  in path B becomes 0 mA approximately. The peak current is set by an applied voltage to LD pin.

The influence of input voltage ( $V_{IN}$ ) change and  $V_f$  of LED change on the LED current ( $I_{LED}$ ) can be reduced to the minimum by this control system. In comparing to other modes, the efficiency can be increased and the noise can be reduced in this mode because M1 switching frequency decreases.

While the current flows in the  $I_{LED}$  path B, it is recommended that the voltage of 0.5 V or more is applied on the VSEN pin.

Not Recommended for New Design

12. Dimming function

This TB62D901FNG incorporates three kinds of dimming function.

Table 1 2 Dimming Control Mode Comparison

Operation mode		Control Methods		Dimming Results		
		Input Pin	Signal Type	LED current	Peak current	Ripple current value
1	PWM Dimming	PWMD	Digital signals	PWMD=H: ON PWMD=L: OFF	Fixed	Fixed
2	Linear Dimming	LD	Analogue voltage	ON	Change	Fixed
3	Ripple Dimming	RC	Analog voltage	ON	Fixed	Changed

12.1 PWM dimming

The LED current is turned on and off according to the PWM signal input to the PWMD input pin. When this function is not used, please connect PWMD to the VREG pin.

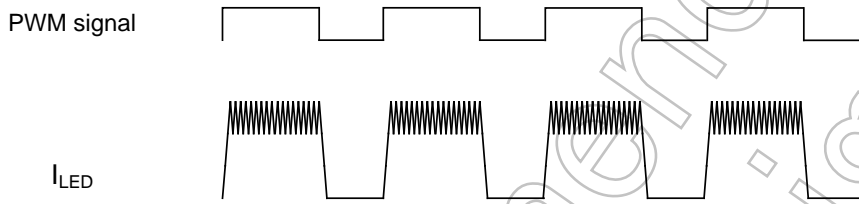

Figure 5 PWM Dimming

12.2 Linear Dimming

This is a linear dimming by controlling the peak current of LED.

The peak current of LED is controlled by  $V_{LD}$  the analog voltage applied to the LD pin from which an internal voltage  $V_{PEAK}$  is derived to the input of an internal comparator. The comparator to compare  $V_{PEAK}$  and the voltage from input ISEN1 of the current sensing resistor  $R_{SET}$ .  $V_{PEAK}$  is determined by method of applied voltage to LD pin.

Table 3  $V_{PEAK}$  setting

Input voltage to LD pin $V_{LD}$	$V_{PEAK}$
The LD and the VREG pins are shorten together. (When not using linear dimming by LD input)	1.0V(TYP.)
The analog voltage is applied to LD pin.	$V_{LD}/1.5$ (TYP.) ( $V_{LD}$ needs to be in the range of 0.2V to 3.8V)

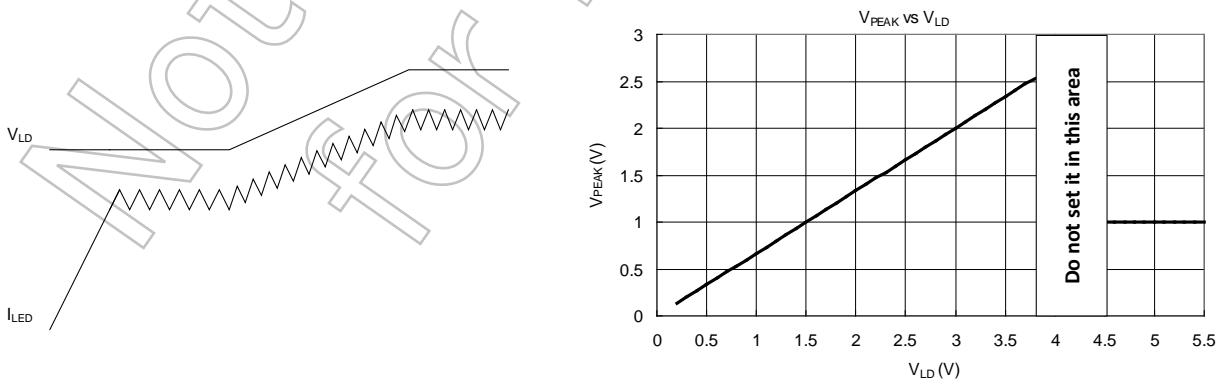

(a) Waveform of LED current vs control voltage  $V_{LD}$  (b) The relation between  $V_{PEAK}$  and  $V_{LD}$

Figure 6 Linear Dimming

12.3 Ripple Dimming

This is a linear dimming by controlling the ripple value of LED current.  
 $T_{OFF}$  of M1 is controlled by the analog voltage input to the RC pin.  
 The ripple value of LED current is adjusted by changing  $T_{OFF}$  of M1.

Table 4 Setting  $T_{OFF}$  of M1

Input to RC pin	$T_{OFF}$
RC pin is connected with the GND. (In case linear dimming by a RC pin isn't applied.)	4 $\mu$ s (TYP.) under the condition that $V_{SEN}$ is 1V.
The analog voltage is input to RC pin.	Please refer to the following graph. Please set the input voltage to a RC pin ( $V_{RC}$ ) in the range of 1.0V to 4.0V.

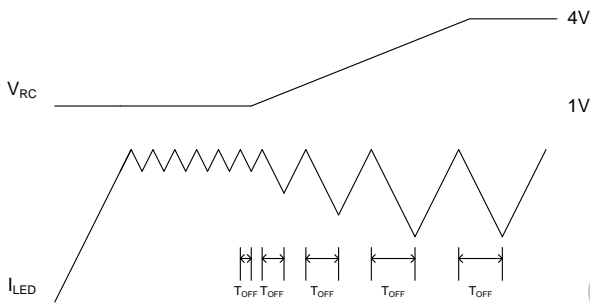

(a) Waveform of operation in adjusting the ripple value by RC pin

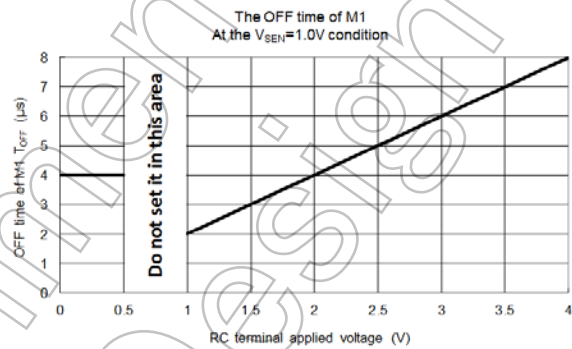

(b) GATE turn OFF time vs  $V_{RC}$

Figure 7 Ripple Dimming

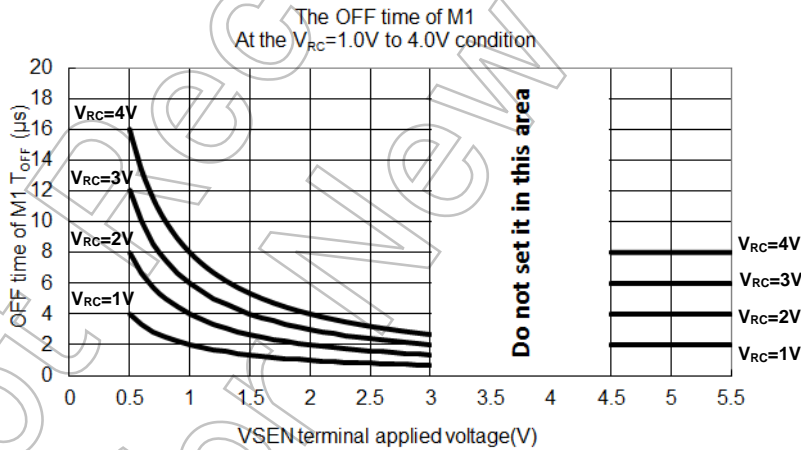

Figure 8 Off time Vs  $V_{RC}$   $V_{SEN}$

Please use the IC by inputting the voltage to the  $V_{SEN}$  pin in the range of 0.5V to 3.0V or 4.5V to  $V_{REG}$ .

### 13. Detection functions

There are several built in detection functions, which are summarized in Table 5

Table 5 Detection Modes

Detection function	Effect	Detection point	detection level	Operation in detection	Reset condition
Thermal shutdown (TSD)	Prevention of overheating	Internal temperature of IC	$T_{TSD}$	It stops switching	Temperature falls by 20°C(TYP.) or more from the detection level
Over-current detection (OCP)	Prevention of over current caused by short-circuit	ISEN1 pin voltage	$V_{OCP}$ When it is detected four consecutive times, the OCP operates	It stops switching	Recycle Power supply or toggle EN
Under-voltage lockout (UVLO)	Prevention of malfunction caused by IC supply voltage abnormality	VCC pin voltage	$V_{UVLO}$	It changes to standby mode.	Vcc rises by 2.5V(TYP.) or more from the detection level
Over-voltage detection (OVP)	Prevention of malfunction caused by IC supply voltage abnormality.	VCC pin voltage	$V_{OVP}$	It stops switching	Recycle Power supply or toggle EN
ISEN1 pin open detection (IOP)	Prevention of over-current caused by detecting pin open.	ISEN1 pin voltage	$V_{PEAK}$ When it is detected that GATE pin voltage is 0V for an extended period, the IOP operates	It stops switching.	Recycle Power supply or toggle EN

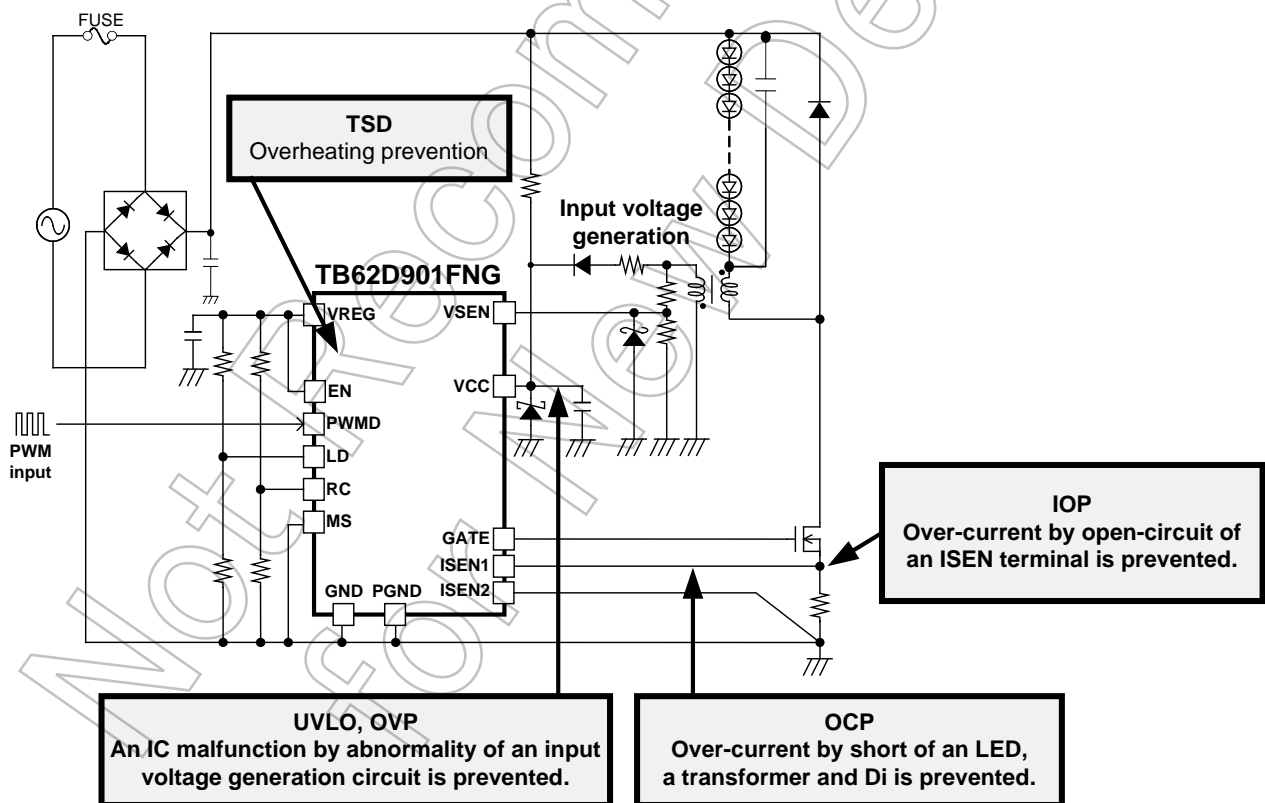

Figure 9 Detection Overview

**13.1 Thermal shutdown function (TSD)**

This function prevents overheating of IC. When the IC internal temperature reaches 140°C (TYP.) or more, the TSD operates.

During TSD, output voltage of the GATE pin becomes 0V. And switching control of power MOSFET is stopped. When the IC temperature falls by 20°C (TYP.) or more from TSD temperature, the normal operation resumes.

**13.2 Over-current detection function (OCP)**

Though LED current is usually controlled to keep the voltage of the ISEN pin ( $V_{PEAK}$ ) or less, the LED current becomes out-of-control and increases suddenly when the LED, the transformer, and the Diode are short-circuited. OCP prevents this sudden increase. OCP operates when the voltage of the ISEN1 pin becomes  $V_{OCP}$  or more for four cycles continuously (It counts from switching of the 2nd shot after power on.).

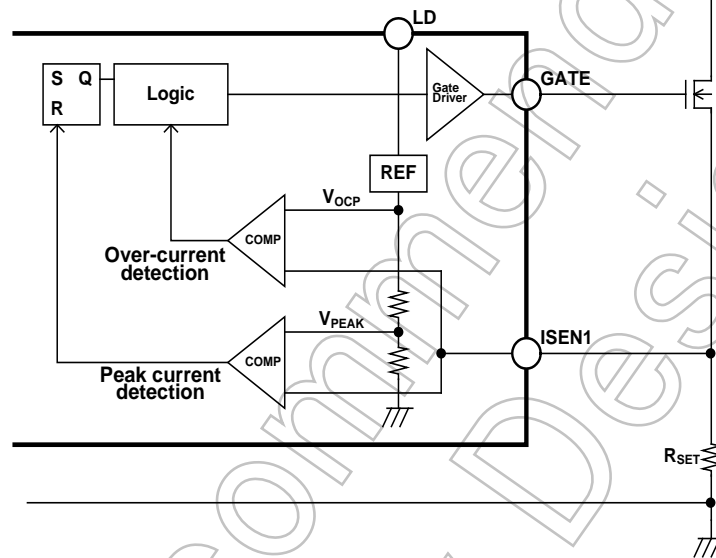

Figure 10 OCP Block Diagram

When OCP operates, output voltage of the GATE pin becomes 0V. And it moves to the switching stop mode. By recycling power supply or toggling EN (EN=H→L→H), it returns to normal operation mode.

Table 6 Setup of  $V_{OCP}$  and  $V_{PEAK}$

Input to the LD pin	$V_{OCP}$	$V_{PEAK}$
LD pin is connected with the pin $V_{REG}$ . (When linear dimming by a LD pin isn't used)	1.6V (TYP.)	1.0V (TYP.)
The analog voltage is input to LD pin.	$V_{LD} + 0.2$ (TYP.) @ $V_{LD} = 3.8V$	$V_{LD} / 1.5$ (TYP.)

**13.3 Under-voltage lockout function (UVLO)**

This function prevents a malfunction in IC supply voltage abnormality caused by trouble of an input voltage generation circuit. When input voltage of the VCC pin becomes 8.5V (TYP.) or less which corresponds to UVLO operation voltage, UVLO operates.

When UVLO operates, output voltage of the GATE pin becomes 0V. And it moves to standby mode. When If input voltage of the VCC pin rises by 2.5V (TYP.) or more from UVLO operation voltage, normal operation resumes.

**13.4 Over-voltage detection function (OVP)**

This function prevents a malfunction in IC supply voltage abnormality caused by trouble of an input voltage generation circuit. This function becomes effective from switching of the 2nd shot after power supplies. When input voltage of the VCC pin becomes 35V (TYP.) or more which corresponds to OVP operation voltage, OVP operates.

When OVP operates, output voltage of the GATE pin becomes 0V. And it moves to switching stop mode. By recycling power supply or toggling EN (EN=H→L→H), normal operation resumes.

**13.5 ISEN1 input open detection function (IOP)**

When the ISEN1 pin, which controls on time, is open, the peak current of LED becomes out-of-control. This function prevents an over-current flowing to an LED.

The path, in which the detection current of 2μA (TYP.) flows, disappears when the ISEN1 pin is open. And the voltage of ISEN1 pin rises. When the voltage of the ISEN1 pin rises to  $V_{PEAK}$  under the condition the t GATE pin voltage is 0V, the IOP operates and it moves to the switching stop mode. By recycling power supply or toggling EN (EN=H→L→H), normal operation resumes.

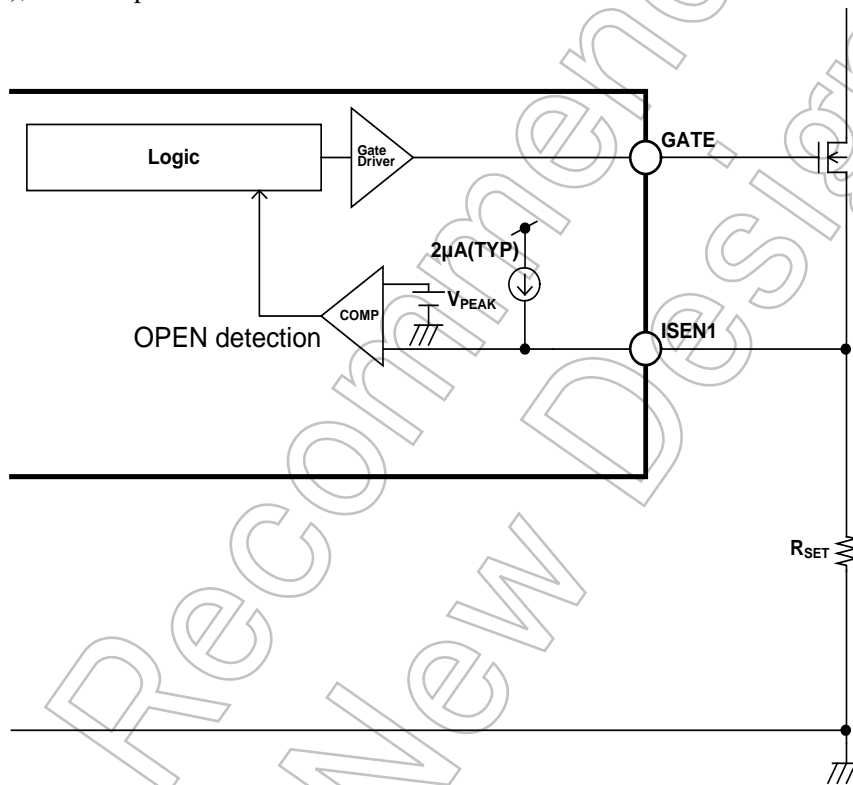

Figure 11 ISEN1 open Detection Block Diagram

14. IC power supply

In normal operation, the current is supplied from the transformer auxiliary winding. And in starting, the current is supplied from the AC line, and it charges  $C_{STA}$  through startup resistance ( $R_{STA}$ ). When the voltage of VCC pin rises above 11V (TYP.) or more, the UVLO is released, and IC starts operation. When the voltage generates in the auxiliary winding of a transformer by switching of power MOSFET, VCC supply from auxiliary winding starts.

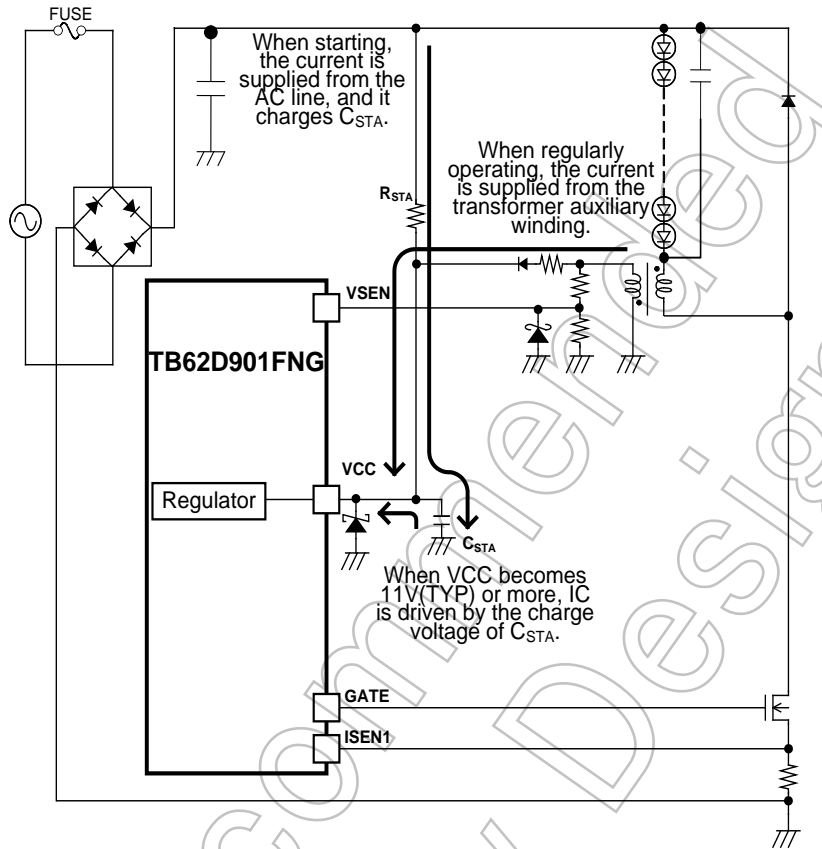

Figure 12 The diagram of power supply

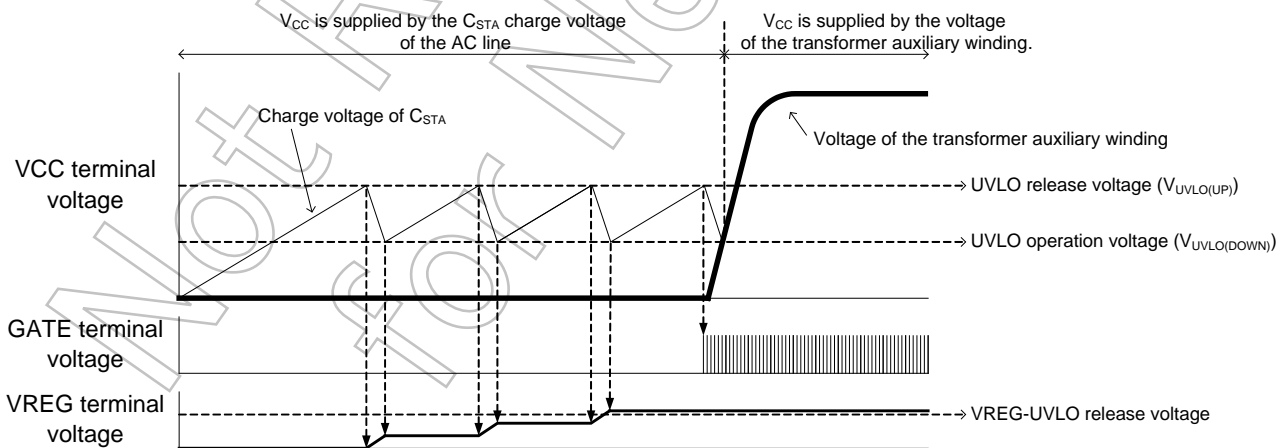

Figure 13 The timing chart of power supply



15. Transition state

15.1 Detection function

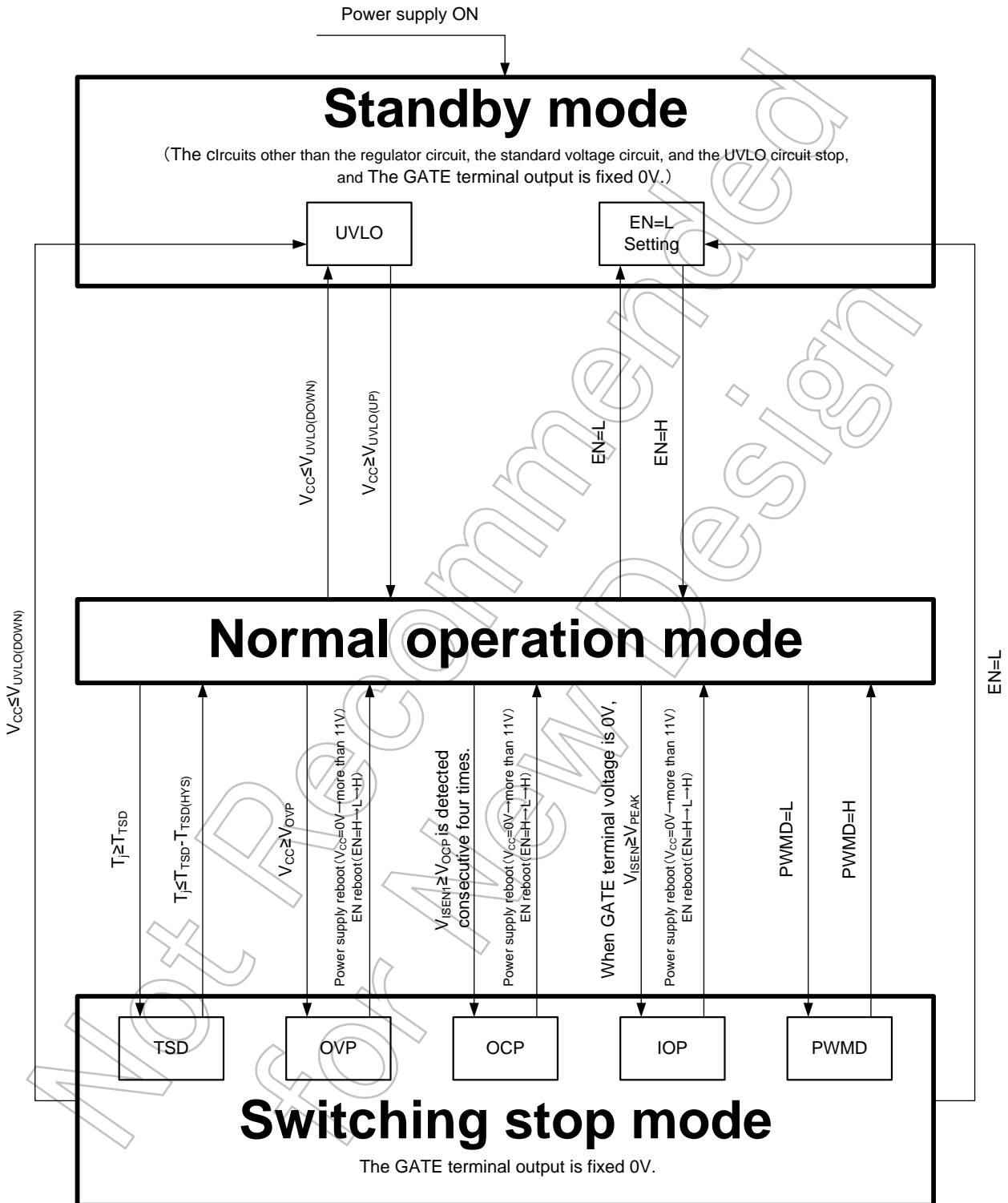

Figure 14 Detection States Transition

When two or more fault conditions occur, the IC will not switch unless the each reset condition is completed.

15.2 GATE control

1. OFF time fixed mode

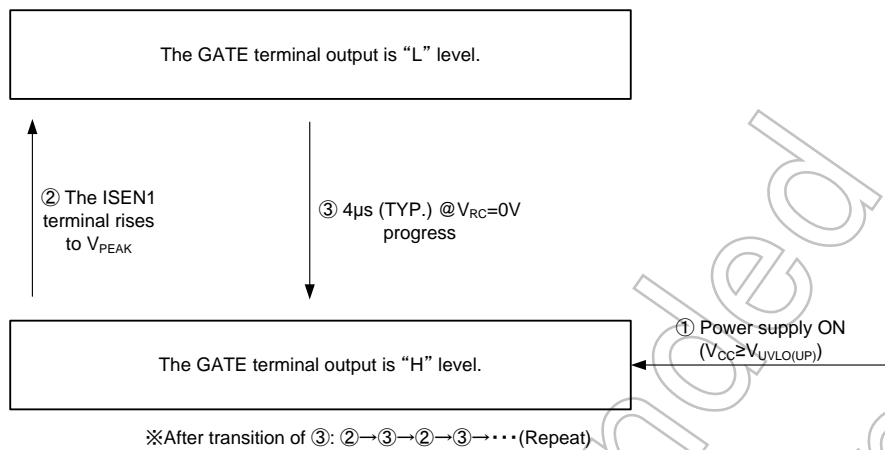

Figure 15 States Transition in Fixed Off time Mode

2. OFF time automatic adjustment mode

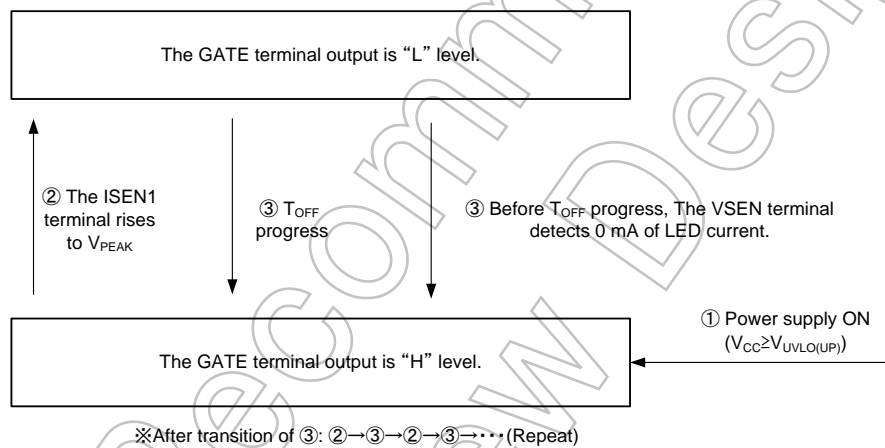

Figure 16 States Transition in Adaptive Off time Mode

3. Critical mode

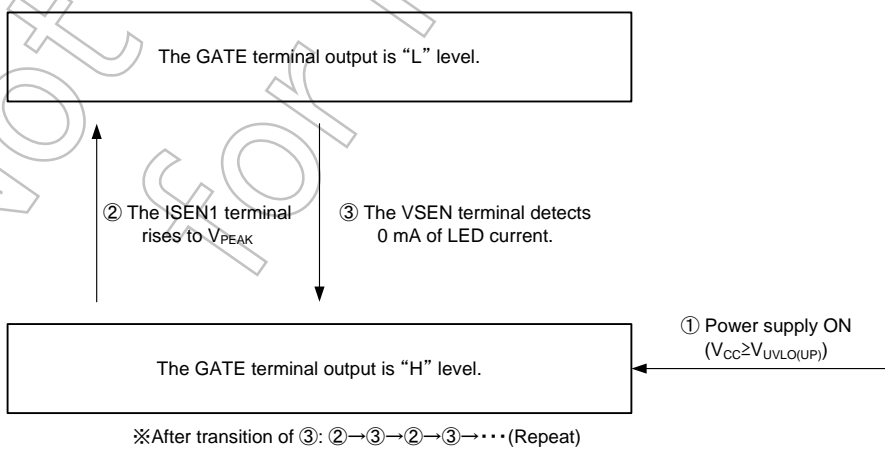
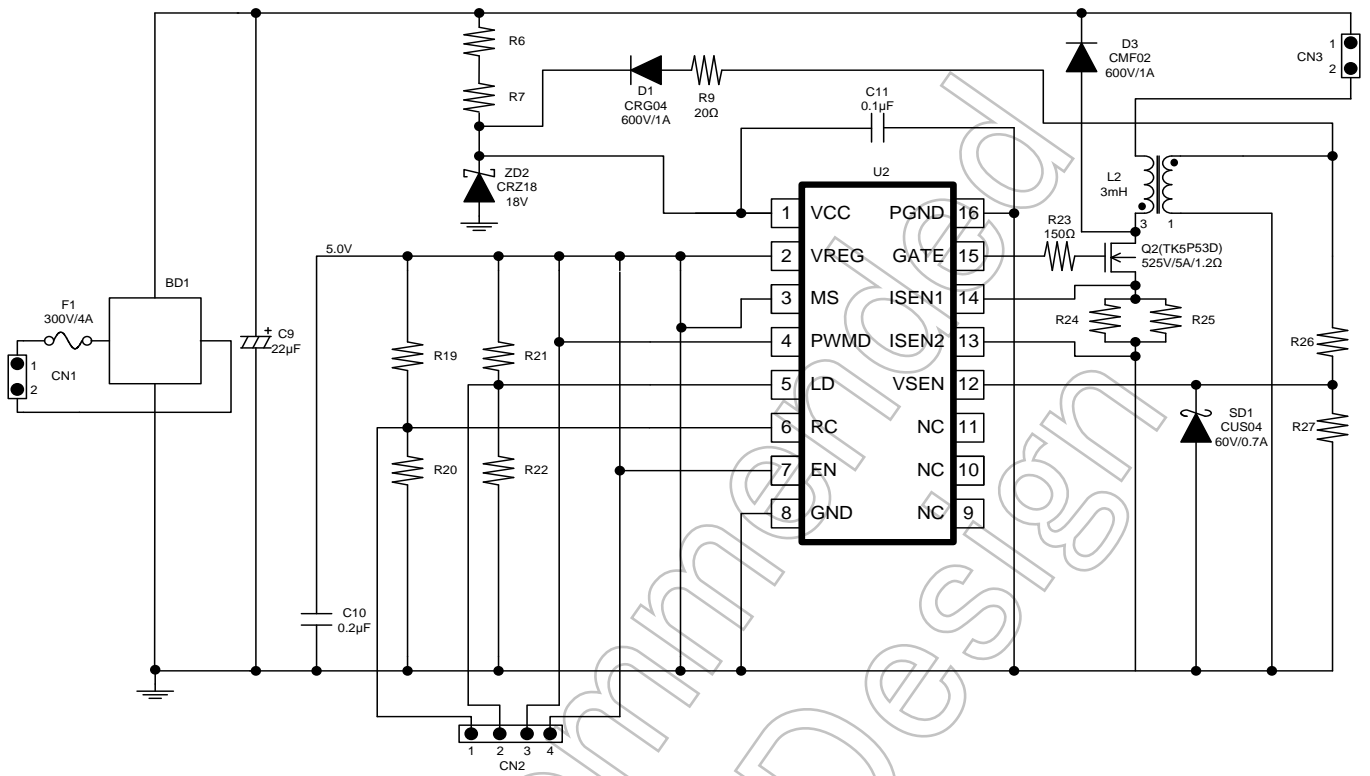

Figure 17 States Transition in Critical Mode

**16. Application diagram**



Not Recommended for New Design

17. Package dimension

Unit: mm

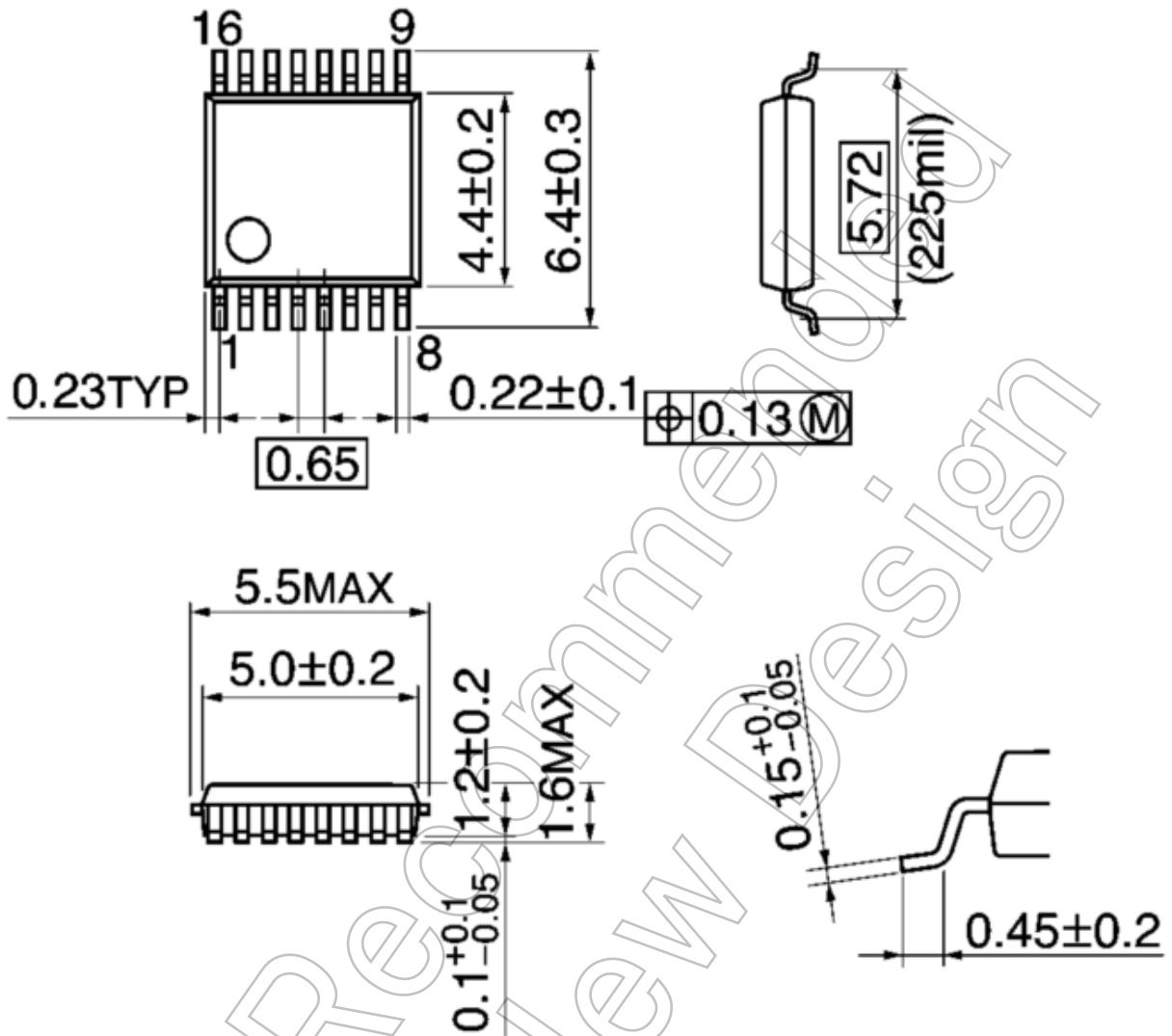

Weight: 0.07 g (typ.)

Not Recommended for New Design

## Notes on Contents

### 1. Block Diagrams

Some of the functional blocks, circuits, or constants in the block diagram may be omitted or simplified for explanatory purposes.

### 2. Equivalent Circuits

The equivalent circuit diagrams may be simplified or some parts of them may be omitted for explanatory purposes.

### 3. Timing Charts

Timing charts may be simplified for explanatory purposes.

### 4. Application Circuits

The application circuits shown in this document are provided for reference purposes only. Thorough evaluation is required, especially at the mass production design stage.

Toshiba does not grant any license to any industrial property rights by providing these examples of application circuits.

### 5. Test Circuits

Components in the test circuits are used only to obtain and confirm the device characteristics. These components and circuits are not guaranteed to prevent malfunction or failure from occurring in the application equipment.

## IC Usage Considerations

### Notes on handling of ICs

- [1] The absolute maximum ratings of a semiconductor device are a set of ratings that must not be exceeded, even for a moment. Do not exceed any of these ratings.  
Exceeding the rating(s) may cause the device breakdown, damage or deterioration, and may result injury by explosion or combustion.
- [2] Use an appropriate power supply fuse to ensure that a large current does not continuously flow in case of over current and/or IC failure. The IC will fully break down when used under conditions that exceed its absolute maximum ratings, when the wiring is routed improperly or when an abnormal pulse noise occurs from the wiring or load, causing a large current to continuously flow and the breakdown can lead smoke or ignition. To minimize the effects of the flow of a large current in case of breakdown, appropriate settings, such as fuse capacity, fusing time and insertion circuit location, are required.
- [3] If your design includes an inductive load such as a motor coil, incorporate a protection circuit into the design to prevent device malfunction or breakdown caused by the current resulting from the inrush current at power ON or the negative current resulting from the back electromotive force at power OFF. IC breakdown may cause injury, smoke or ignition.  
Use a stable power supply with ICs with built-in protection functions. If the power supply is unstable, the protection function may not operate, causing IC breakdown. IC breakdown may cause injury, smoke or ignition.
- [4] Do not insert devices in the wrong orientation or incorrectly.  
Make sure that the positive and negative terminals of power supplies are connected properly.  
Otherwise, the current or power consumption may exceed the absolute maximum rating, and exceeding the rating(s) may cause the device breakdown, damage or deterioration, and may result injury by explosion or combustion.  
In addition, do not use any device that is applied the current with inserting in the wrong orientation or incorrectly even just one time.

[5] Carefully select external components (such as inputs and negative feedback capacitors) and load components (such as speakers), for example, power amp and regulator.

If there is a large amount of leakage current such as input or negative feedback condenser, the IC output DC voltage will increase. If this output voltage is connected to a speaker with low input withstand voltage, overcurrent or IC failure can cause smoke or ignition. (The over current can cause smoke or ignition from the IC itself.) In particular, please pay attention when using a Bridge Tied Load (BTL) connection type IC that inputs output DC voltage to a speaker directly.

### Points to remember on handling of ICs

#### (1) Heat Radiation Design

In using an IC with large current flow such as power amp, regulator or driver, please design the device so that heat is appropriately radiated, not to exceed the specified junction temperature ( $T_j$ ) at any time and condition. These ICs generate heat even during normal use. An inadequate IC heat radiation design can lead to decrease in IC life, deterioration of IC characteristics or IC breakdown. In addition, please design the device taking into consideration the effect of IC heat radiation with peripheral components.

#### (2) Back-EMF

When a motor rotates in the reverse direction, stops or slows down abruptly, a current flows back to the motor's power supply due to the effect of back-EMF. If the current sink capability of the power supply is small, the device's motor power supply and output pins might be exposed to conditions beyond absolute maximum ratings. To avoid this problem, take the effect of back-EMF into consideration in system design.

Not Recommended  
for New Design

## RESTRICTIONS ON PRODUCT USE

- Toshiba Corporation, and its subsidiaries and affiliates (collectively "TOSHIBA"), reserve the right to make changes to the information in this document, and related hardware, software and systems (collectively "Product") without notice.
- This document and any information herein may not be reproduced without prior written permission from TOSHIBA. Even with TOSHIBA's written permission, reproduction is permissible only if reproduction is without alteration/omission.
- Though TOSHIBA works continually to improve Product's quality and reliability, Product can malfunction or fail. Customers are responsible for complying with safety standards and for providing adequate designs and safeguards for their hardware, software and systems which minimize risk and avoid situations in which a malfunction or failure of Product could cause loss of human life, bodily injury or damage to property, including data loss or corruption. Before customers use the Product, create designs including the Product, or incorporate the Product into their own applications, customers must also refer to and comply with (a) the latest versions of all relevant TOSHIBA information, including without limitation, this document, the specifications, the data sheets and application notes for Product and the precautions and conditions set forth in the "TOSHIBA Semiconductor Reliability Handbook" and (b) the instructions for the application with which the Product will be used with or for. Customers are solely responsible for all aspects of their own product design or applications, including but not limited to (a) determining the appropriateness of the use of this Product in such design or applications; (b) evaluating and determining the applicability of any information contained in this document, or in charts, diagrams, programs, algorithms, sample application circuits, or any other referenced documents; and (c) validating all operating parameters for such designs and applications. **TOSHIBA ASSUMES NO LIABILITY FOR CUSTOMERS' PRODUCT DESIGN OR APPLICATIONS.**
- **PRODUCT IS NEITHER INTENDED NOR WARRANTED FOR USE IN EQUIPMENTS OR SYSTEMS THAT REQUIRE EXTRAORDINARILY HIGH LEVELS OF QUALITY AND/OR RELIABILITY, AND/OR A MALFUNCTION OR FAILURE OF WHICH MAY CAUSE LOSS OF HUMAN LIFE, BODILY INJURY, SERIOUS PROPERTY DAMAGE AND/OR SERIOUS PUBLIC IMPACT ("UNINTENDED USE").** Except for specific applications as expressly stated in this document, Unintended Use includes, without limitation, equipment used in nuclear facilities, equipment used in the aerospace industry, medical equipment, equipment used for automobiles, trains, ships and other transportation, traffic signaling equipment, equipment used to control combustions or explosions, safety devices, elevators and escalators, devices related to electric power, and equipment used in finance-related fields. **IF YOU USE PRODUCT FOR UNINTENDED USE, TOSHIBA ASSUMES NO LIABILITY FOR PRODUCT.** For details, please contact your TOSHIBA sales representative.
- Do not disassemble, analyze, reverse-engineer, alter, modify, translate or copy Product, whether in whole or in part.
- Product shall not be used for or incorporated into any products or systems whose manufacture, use, or sale is prohibited under any applicable laws or regulations.
- The information contained herein is presented only as guidance for Product use. No responsibility is assumed by TOSHIBA for any infringement of patents or any other intellectual property rights of third parties that may result from the use of Product. No license to any intellectual property right is granted by this document, whether express or implied, by estoppel or otherwise.
- **ABSENT A WRITTEN SIGNED AGREEMENT, EXCEPT AS PROVIDED IN THE RELEVANT TERMS AND CONDITIONS OF SALE FOR PRODUCT, AND TO THE MAXIMUM EXTENT ALLOWABLE BY LAW, TOSHIBA (1) ASSUMES NO LIABILITY WHATSOEVER, INCLUDING WITHOUT LIMITATION, INDIRECT, CONSEQUENTIAL, SPECIAL, OR INCIDENTAL DAMAGES OR LOSS, INCLUDING WITHOUT LIMITATION, LOSS OF PROFITS, LOSS OF OPPORTUNITIES, BUSINESS INTERRUPTION AND LOSS OF DATA, AND (2) DISCLAIMS ANY AND ALL EXPRESS OR IMPLIED WARRANTIES AND CONDITIONS RELATED TO SALE, USE OF PRODUCT, OR INFORMATION, INCLUDING WARRANTIES OR CONDITIONS OF MERCHANTABILITY, FITNESS FOR A PARTICULAR PURPOSE, ACCURACY OF INFORMATION, OR NONINFRINGEMENT.**
- Do not use or otherwise make available Product or related software or technology for any military purposes, including without limitation, for the design, development, use, stockpiling or manufacturing of nuclear, chemical, or biological weapons or missile technology products (mass destruction weapons). Product and related software and technology may be controlled under the applicable export laws and regulations including, without limitation, the Japanese Foreign Exchange and Foreign Trade Law and the U.S. Export Administration Regulations. Export and re-export of Product or related software or technology are strictly prohibited except in compliance with all applicable export laws and regulations.
- Please contact your TOSHIBA sales representative for details as to environmental matters such as the RoHS compatibility of Product. Please use Product in compliance with all applicable laws and regulations that regulate the inclusion or use of controlled substances, including without limitation, the EU RoHS Directive. **TOSHIBA ASSUMES NO LIABILITY FOR DAMAGES OR LOSSES OCCURRING AS A RESULT OF NONCOMPLIANCE WITH APPLICABLE LAWS AND REGULATIONS.**