

**RF3603D**

**316.4 MHz  
SAW Filter**

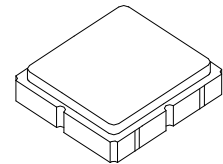

**SM3838-8**

- 310.0 to 319.5 MHz Filter
- Optimized for use with the TRC105 Transceiver
- Balanced 150 ohm IC Interface
- Complies with Directive 2002/95/EC (RoHS)
- Moisture Sensitivity Level: 1

**Absolute Maximum Ratings**

Rating	Value	Units
Input Power Level	+15	dBm
DC Voltage	±5	V
Operating Temperature Range	-40 to +85	°C
Storage Temperature Range in Tape and Reel	-40 to +85	°C
Maximum Soldering Profile, 5 cycles/ 10 seconds maximum	265	°C

**Electrical Characteristics**

Characteristic	Sym	Notes	Min	Typ	Max	Units	
Center Frequency	$f_C$			316.4		MHz	
1 dB Bandwidth	$BW_1$			13		MHz	
Maximum Insertion Loss, 310.0 to 319.5 MHz	$IL_{MAX}$			1.8	2.2	dB	
Amplitude Ripple, p-p, 310.0 to 319.5 MHz					1.0		
Rejection Referenced to Insertion Loss at 315.0 MHz:							
DC to 300 MHz			37	39			
336 to 366 MHz			18	22			
366 to 966 MHz			43	47			
966 to 1266 MHz			43	48			
1266 to 2000 MHz			28	32			
Source Impedance	$Z_S$			50		$\Omega$	
Balanced Load Impedance	$Z_L$			150		$\Omega$	

Case Style	SM3838-8 3.8 x 3.8 mm Nominal Footprint		
Lid Symbolization (Y=year, WW=week, S=shift) dot=pin 1 indicator	886, <u>YWWS</u>		
Standard Reel Quantity	Reel Size 7 Inch	500 Pieces/Reel	
	Reel Size 13 Inch	3000 Pieces/Reel	

**Electrical Connections**

Connection	Terminals
Single-ended Port	6
Balanced Port	1, 3
Case Ground	4, 5, 7, 8
No Connection	2

 **CAUTION: Electrostatic Sensitive Device. Observe precautions for handling.**

**NOTES:**

1. The design, manufacturing process, and specifications of this device are subject to change.
2. US or International patents may apply.
3. RoHS compliant from the first date of manufacture.

## RF3603D-TRC105 Application Circuit

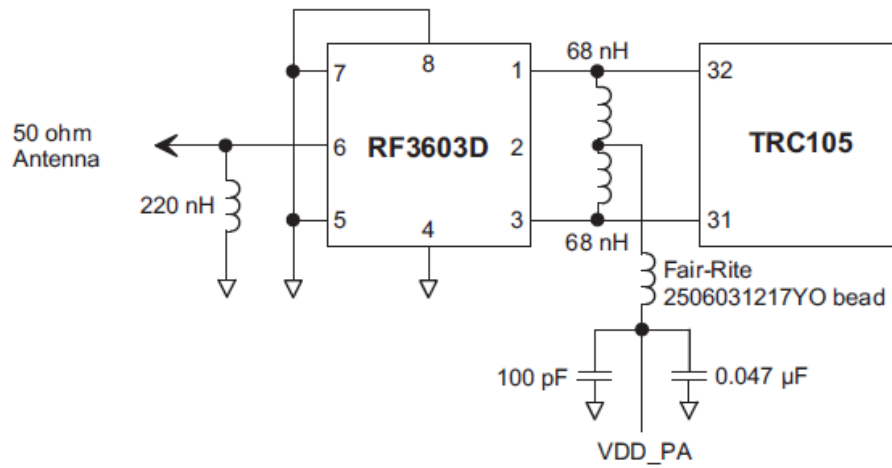

Reference Circuit Diagram Only  
Note: TRC105 has been obsoleted

## RF3603D 50 Ohm Tuning Network

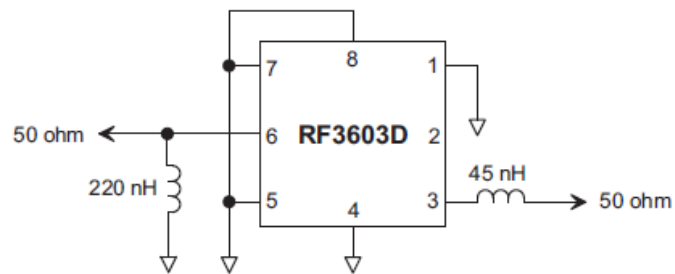

# RF3603D Broadband Response, 200 to 2000 MHz

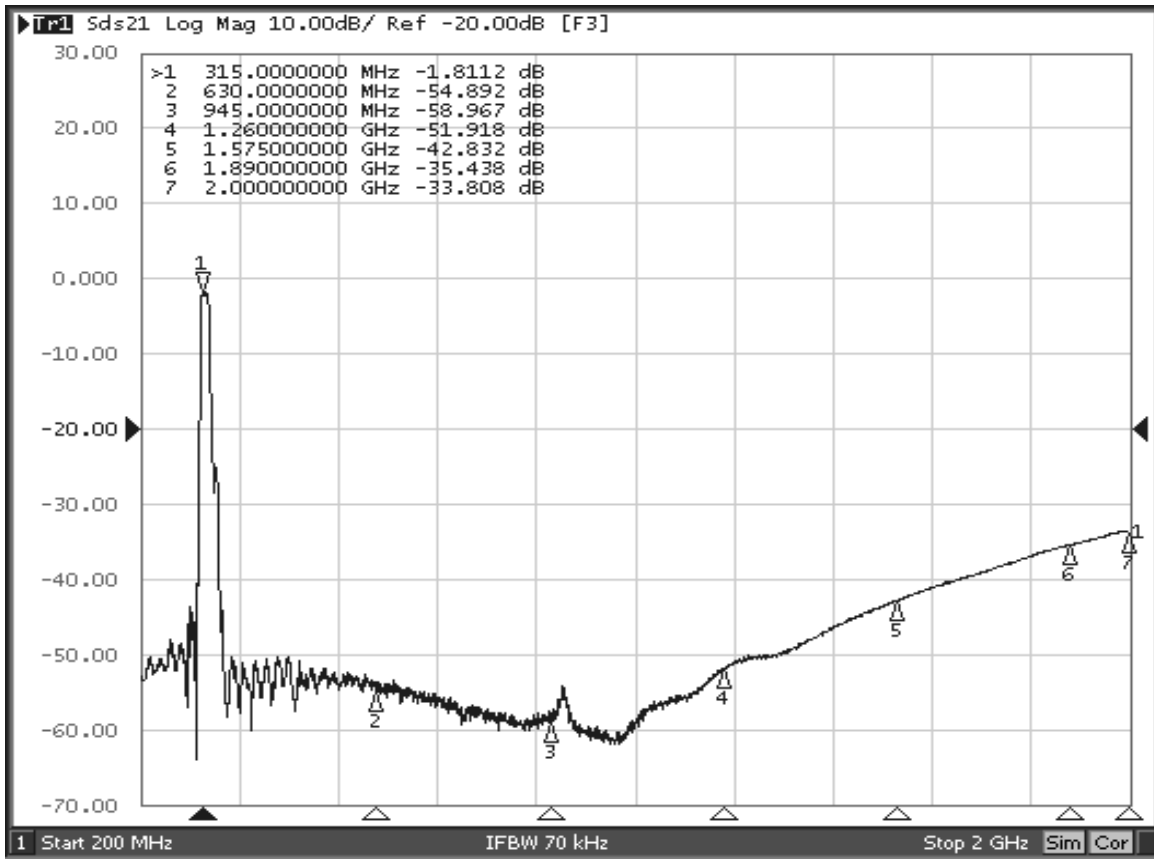

# RF3603D Response, 216.4 to 416.4 MHz

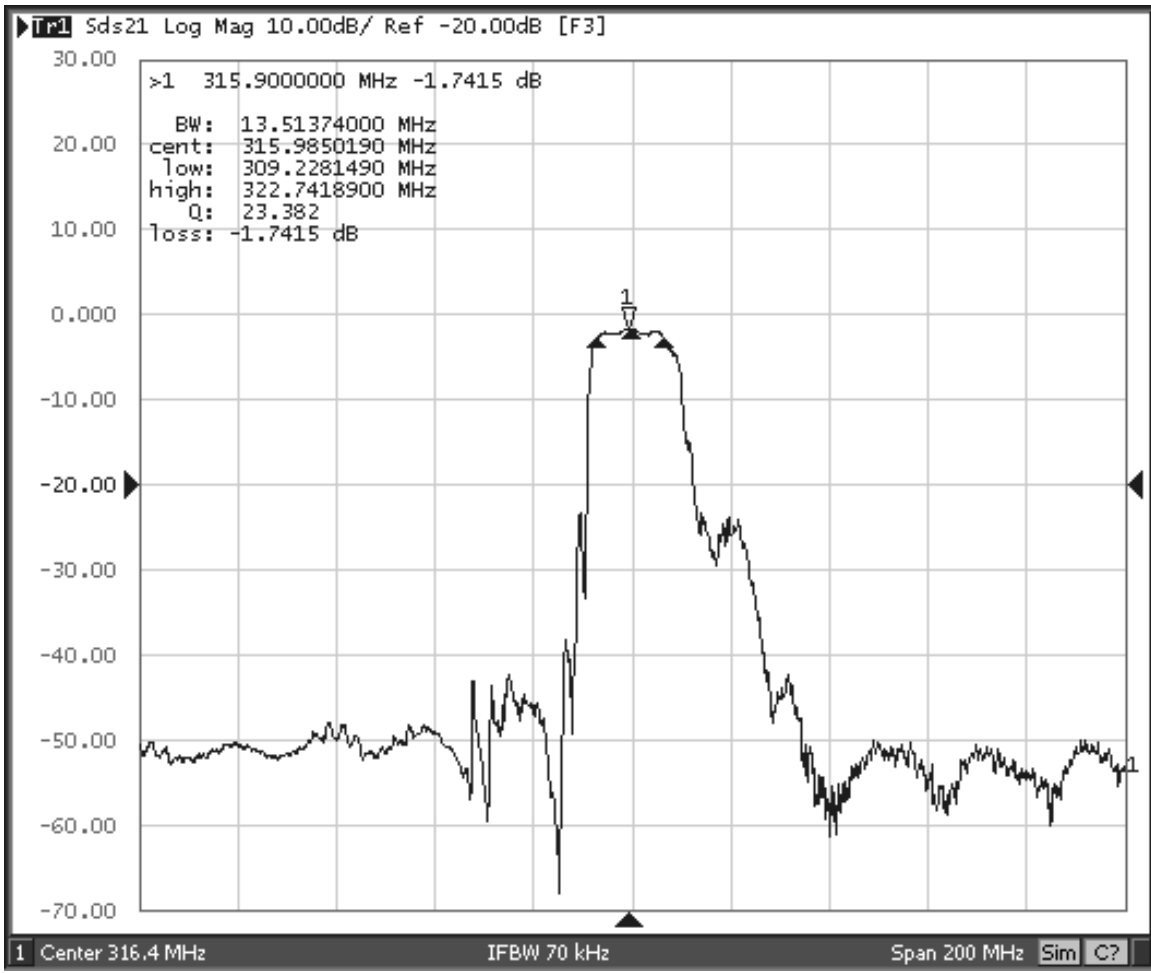

# RF3603D Response, 266.4 to 366.4 MHz

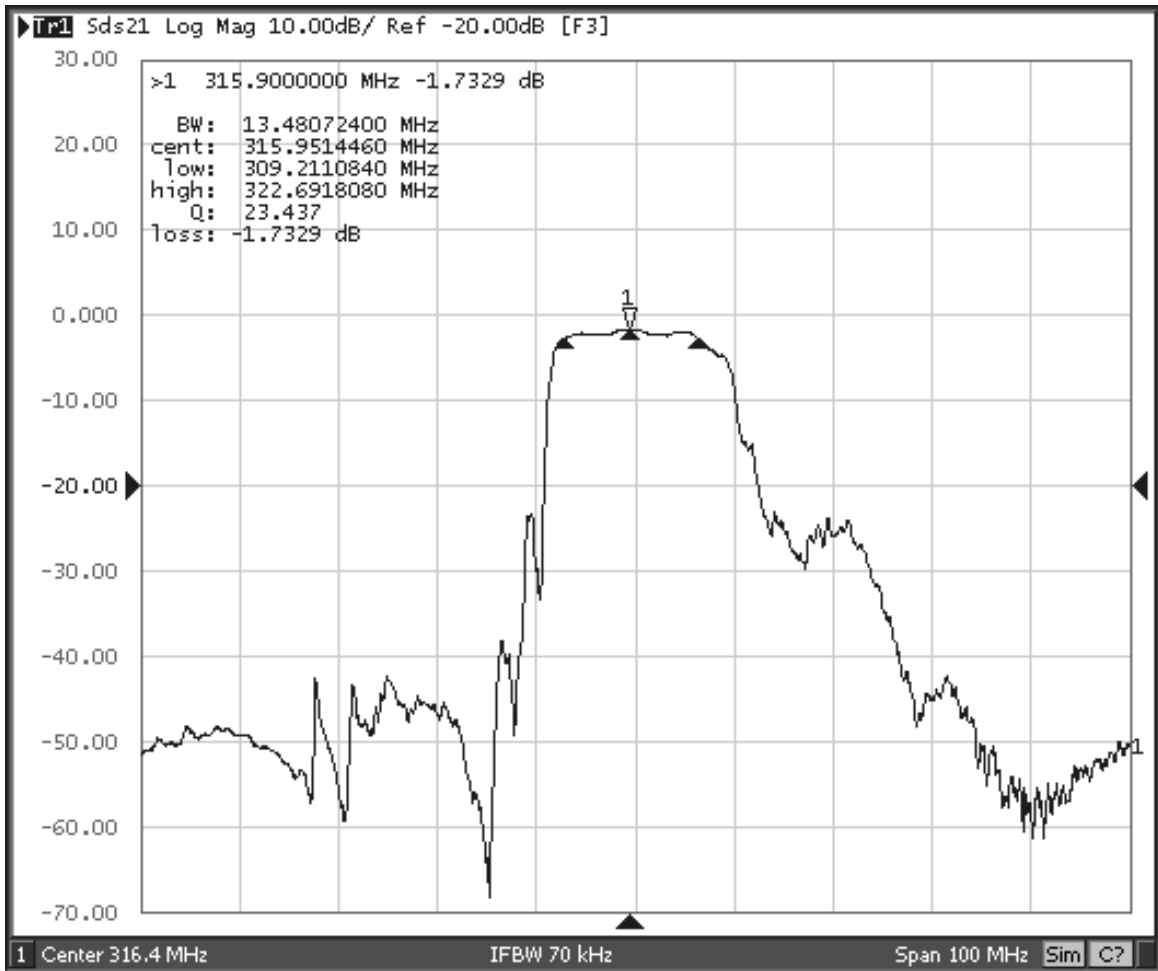

# RF3603D Passband Response

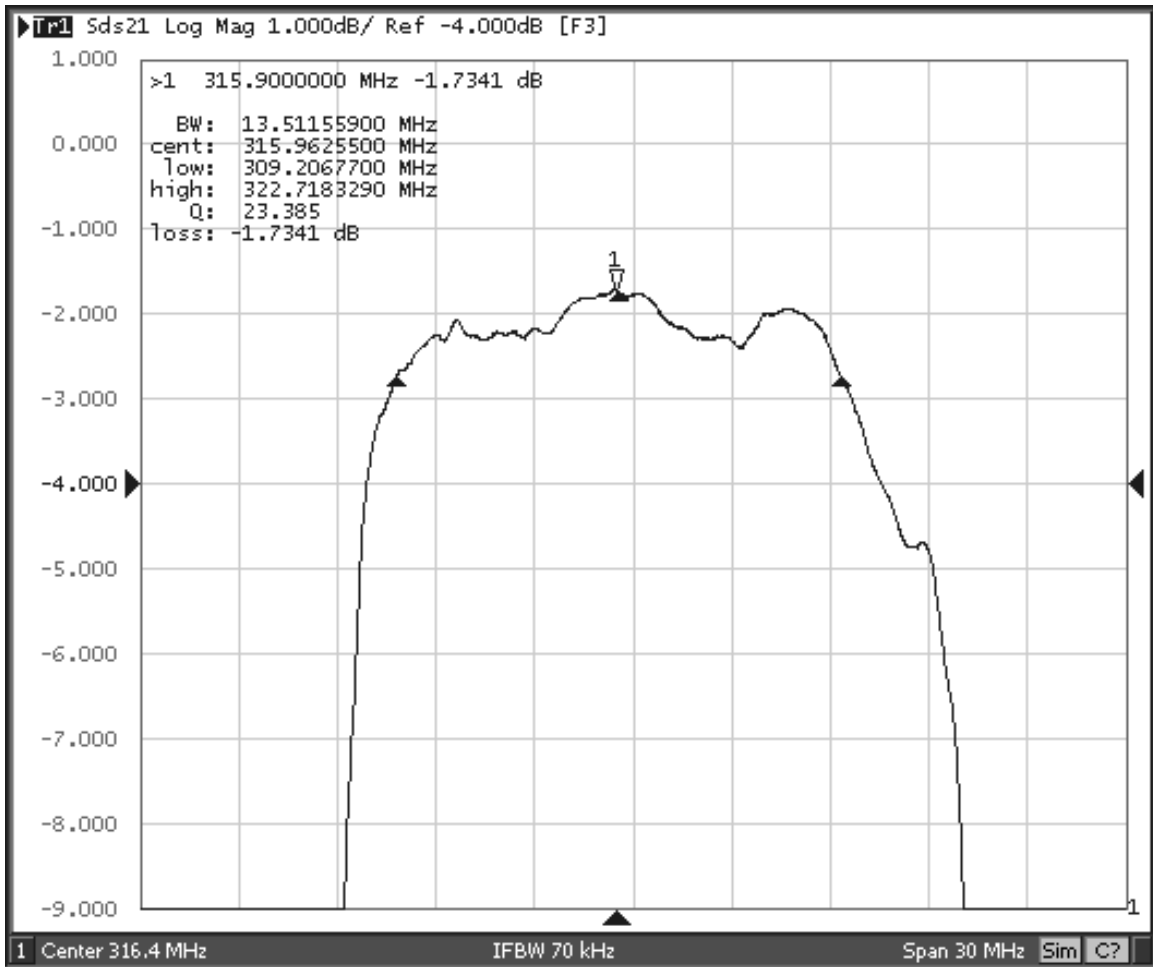

## RF3603D Input Impedance Plot

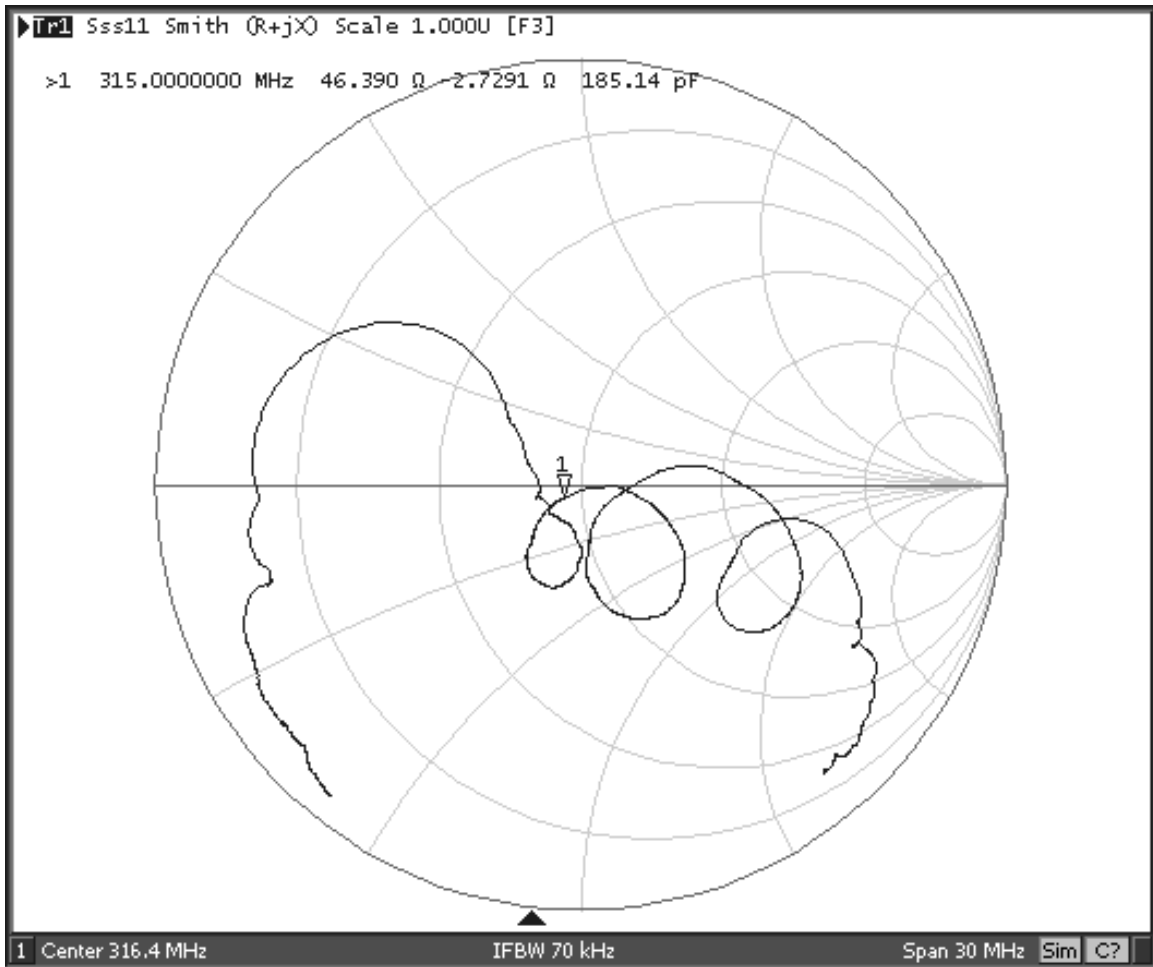

## RF3603D Balanced Output Impedance Plot

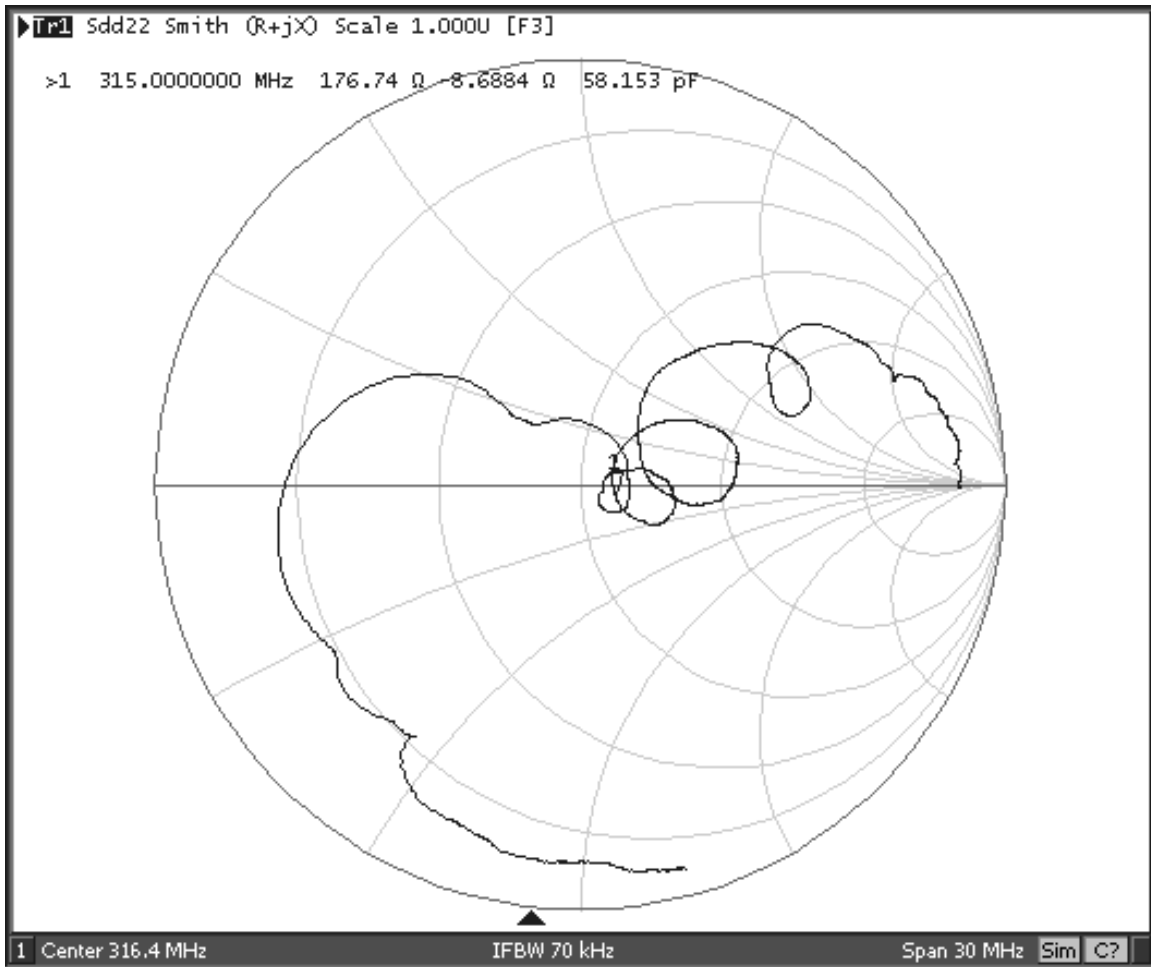



## 8-Terminal Ceramic Surface-Mount Case 3.8 X 3.8 mm Nominal Footprint

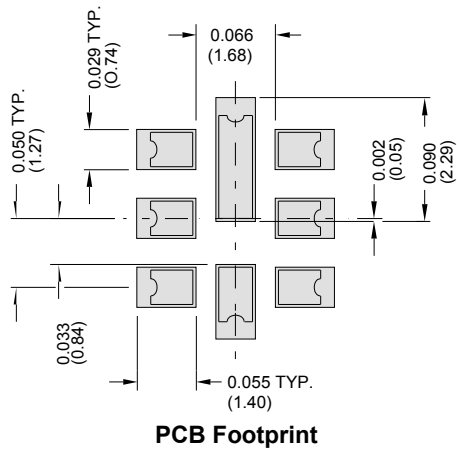

Case Dimensions						
Dimension	mm			Inches		
	Min	Nom	Max	Min	Nom	Max
A	3.6	3.8	4.0	0.142	0.150	0.157
B	3.6	3.8	4.0	0.142	0.150	0.157
C	0.90	1.00	1.1	0.035	0.040	0.043
D	0.80	0.90	1.0	0.031	0.035	0.040
E	0.90	1.00	1.10	0.035	0.040	0.043
F	0.50	0.60	0.70	0.020	0.024	0.028
G	2.39	2.54	2.69	0.090	0.100	0.110
H	1.40	1.75	2.05	0.055	0.069	0.080

Materials	
Solder Pad Plating	0.3 to 1.0 $\mu\text{m}$ Gold over 1.27 to 8.89 $\mu\text{m}$ Nickel
Lid Plating	2.0 to 3.0 $\mu\text{m}$ Nickel
Body	$\text{Al}_2\text{O}_3$ Ceramic

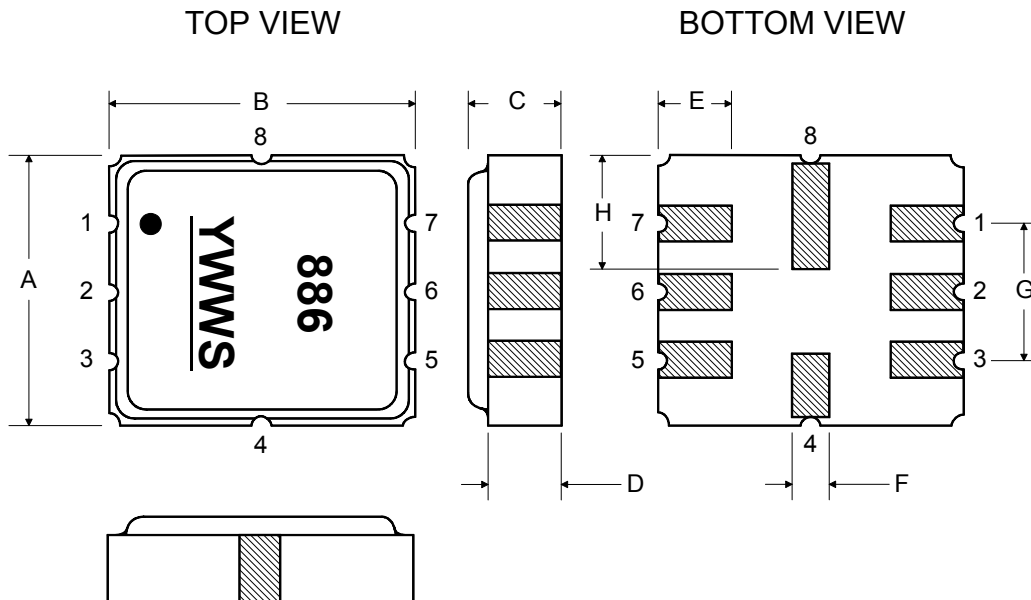

## Tape and Reel Specifications

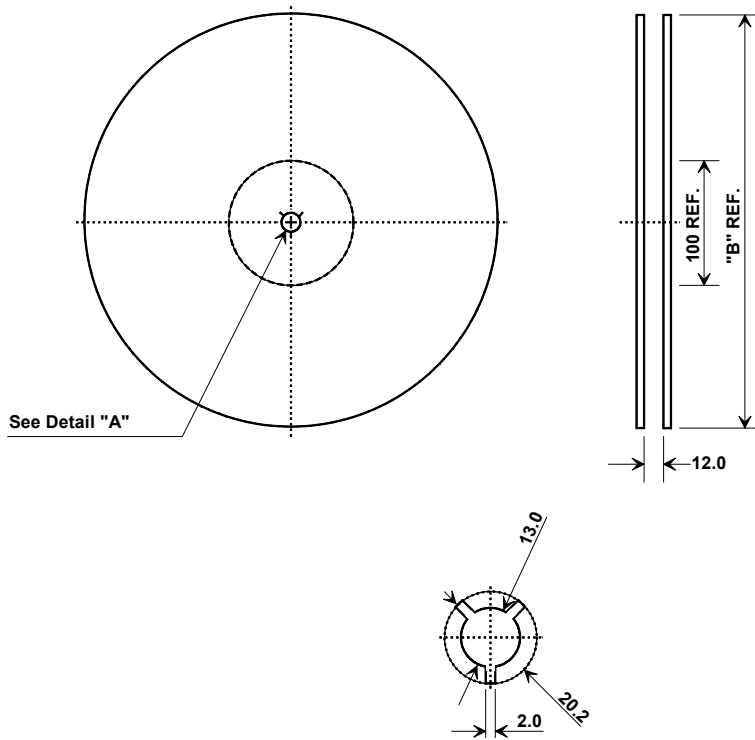

Tape and Reel Standard per ANSI/EIA-481

"B"		Quantity Per Reel
Nominal Size		
Inches	millimeters	
7	178	500
13	330	3000

### COMPONENT ORIENTATION and DIMENSIONS

Carrier Tape Dimensions	
Ao	4.25 mm
Bo	4.25 mm
Ko	1.30 mm
Pitch	8.0 mm
W	12.0 mm

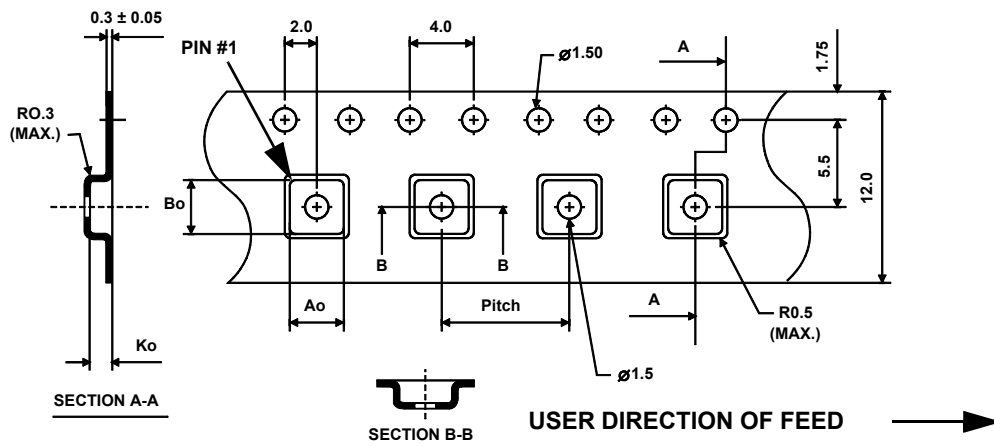

## Recommended Reflow Profile

1. Preheating shall be fixed at 150~180°C for 60~90 seconds.
2. Ascending time to preheating temperature 150°C shall be 30 seconds min.
3. Heating shall be fixed at 220°C for 50~80 seconds and at 260°C +0/-5°C peak (10 seconds).
4. Time: 5 times maximum.

