



# TAOGLAS®



# Datasheet

## DSGP.1575.18.2.A.02

### Description:

GPS L1 / GALILEO E1 1575.42MHz 18\*18\*2mm Ceramic Patch SMD Antenna

### Features:

2.4 dBi Peak Gain for GPS/GALILEO Band  
Dimensions: 18 x 18 x 2mm  
SMD Direct Mount Ceramic Patch Antenna  
TS16949 Approved  
RoHS & Reach Compliant

1. Introduction	3
2. Specifications	4
3. Antenna Characteristics	6
4. Radiation Patterns	8
5. Mechanical Drawing	10
6. Footprint	11
7. Recommended Solder Reflow	13
8. Packaging	14
Changelog	16

Taoglas makes no warranties based on the accuracy or completeness of the contents of this document and reserves the right to make changes to specifications and product descriptions at any time without notice. Taoglas reserves all rights to this document and the information contained herein. Reproduction, use or disclosure to third parties without express permission is strictly prohibited.



## 1. Introduction

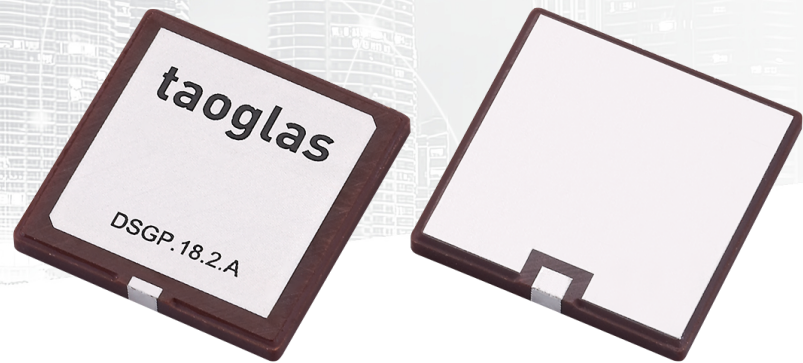

The DSGP.1575.18.2.A.02 is a ceramic GPS L1 / GALILEO E1 passive patch antenna, 18mm square, with a low profile of 2mm thickness. It is designed for applications in space constrained navigation devices, vehicle tracking/fleet management systems, as well as telematics devices.

The antenna has been tuned on a 50 x 50 mm ground plane, working at 1575.42MHz with a 2.4 dBi gain. The ceramic patch is mounted via SMT process, ideal for high volume low cost assembly. It is manufactured and tested in a TS16949 first tier automotive approved facility.

For further optimization to customer specific device environments where ground-plane size is different, custom tuned patch antennas can be supplied. For more details please contact your regional Taoglas sales office.

## 2. Specifications

GNSS Frequency Bands Covered							
<b>GPS/QZSS</b>	L1 1575.42MHz	L2 1227.6MHz	L5 1176.45MHz	L6 1278.75MHz			
	<input checked="" type="checkbox"/>	<input type="checkbox"/>	<input type="checkbox"/>	<input type="checkbox"/>			
<b>GLONASS</b>	L5R 1176.45MHz	L3PT 1201.5MHz	L2PT 1246MHz	L1CR 1575.42MHz	L1PT 1602MHz		
	<input type="checkbox"/>	<input type="checkbox"/>	<input type="checkbox"/>	<input checked="" type="checkbox"/>	<input type="checkbox"/>		
<b>Galileo</b>	E5a 1176.45MHz	E5b 1201.5MHz	E4 1215MHz	E3 1256MHz	E6 1278.75MHz	E2 1561MHz	L1 1575.42MHz
	<input type="checkbox"/>	<input type="checkbox"/>	<input type="checkbox"/>	<input type="checkbox"/>	<input type="checkbox"/>	<input type="checkbox"/>	<input checked="" type="checkbox"/>
<b>BeiDou</b>	B1 1561MHz	B2 1207.14MHz	B3 1268.52MHz				
	<input type="checkbox"/>	<input type="checkbox"/>	<input type="checkbox"/>				
<b>Compass</b>	E5B(B2)/ E6(B3) 1268.56MHz	E2(B1) 1561MHz					
	<input type="checkbox"/>	<input type="checkbox"/>					
<b>SBAS</b>	Omnistar 1542.5MHz	WAAS/EGN OS 1575.42MHz					
	<input type="checkbox"/>	<input checked="" type="checkbox"/>					

Electrical	
Frequency (MHz)	1575.42
VSWR (max.)	2.0:1
Passive Antenna Efficiency (%)	55.94
Passive Antenna Gain at Zenith (dBi)	2.4
Return Loss (dB)	<-10
Impedance	50Ω
Mechanical	
Height	255 ± 5 mm
Base Diameter	16.05 ± 0.2 mm
Whip Diameter	4 ± 0.2 mm
Casing	ABS
Connector	TNC Male
Environmental	
Temperature Range	-40°C to 85°C
Humidity	Non-condensing 65°C 95% RH
Moisture Sensitivity Level (MSL)	3 (168 Hours)

### 3. Antenna Characteristics

#### 3.1 Return Loss

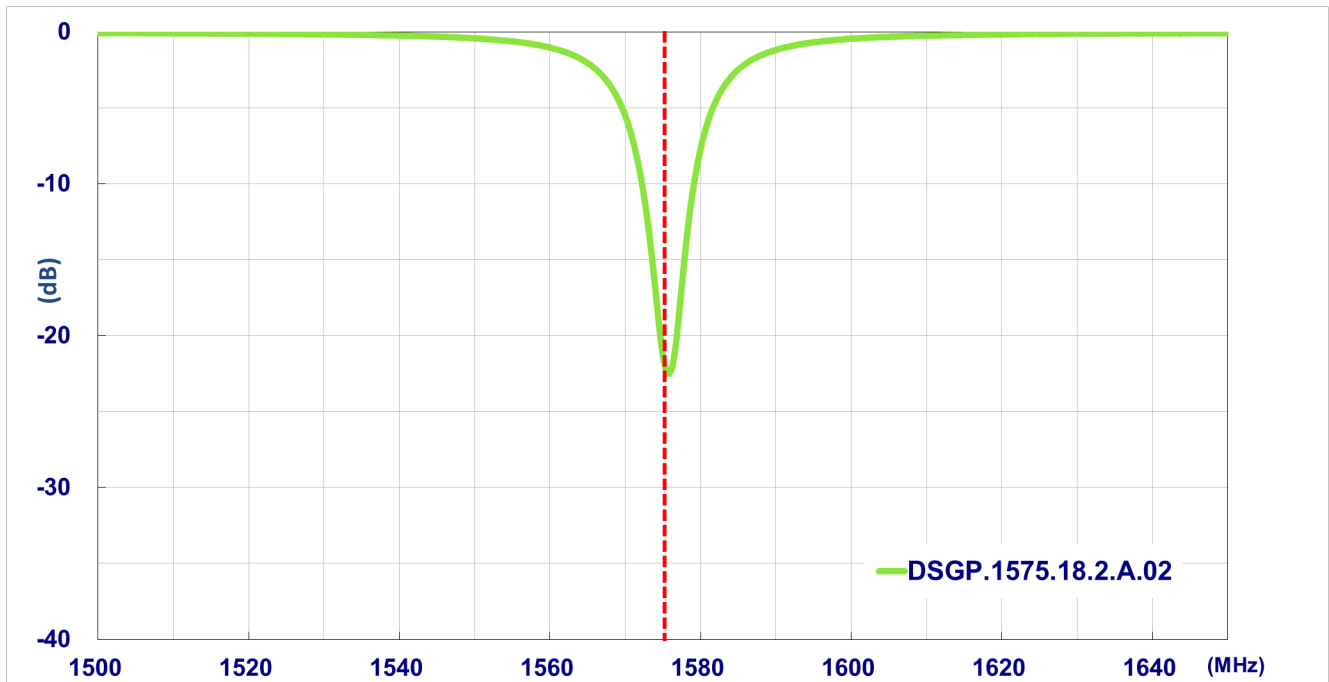

#### 3.2 Efficiency

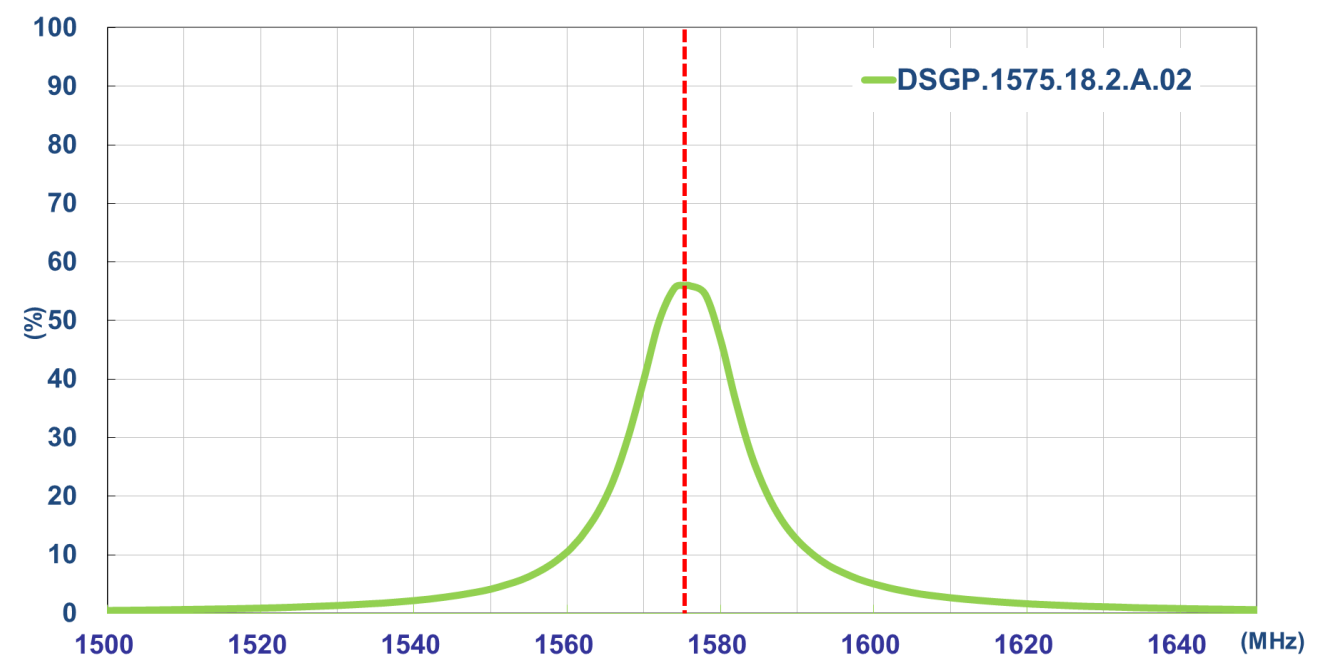

### 3.3 Average Gain

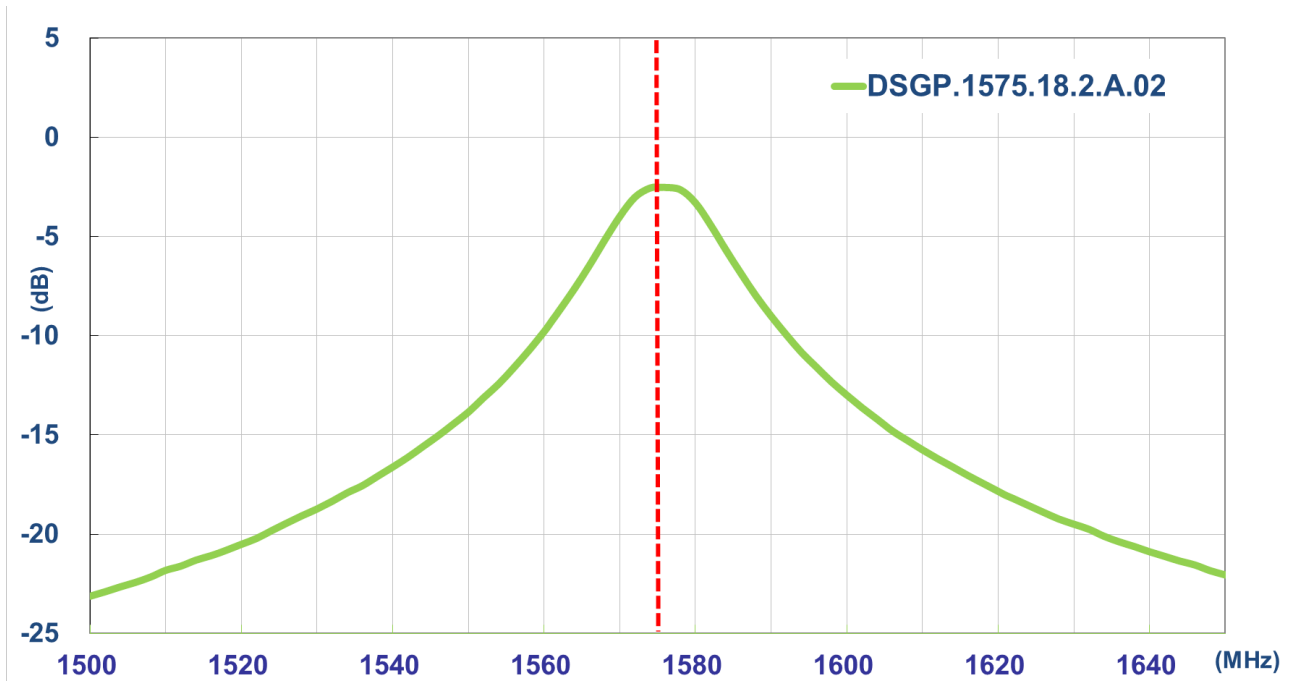

### 3.4 Peak Gain

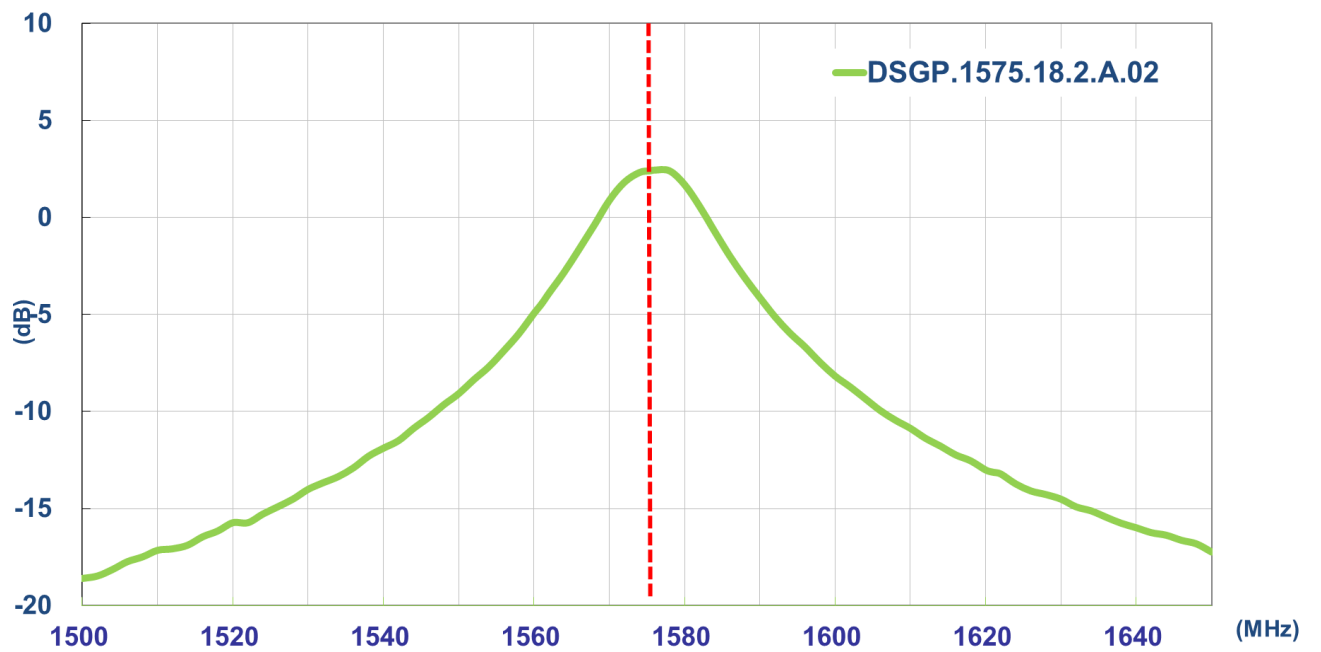

## 4. Radiation Patterns

### 4.1 Test Setup

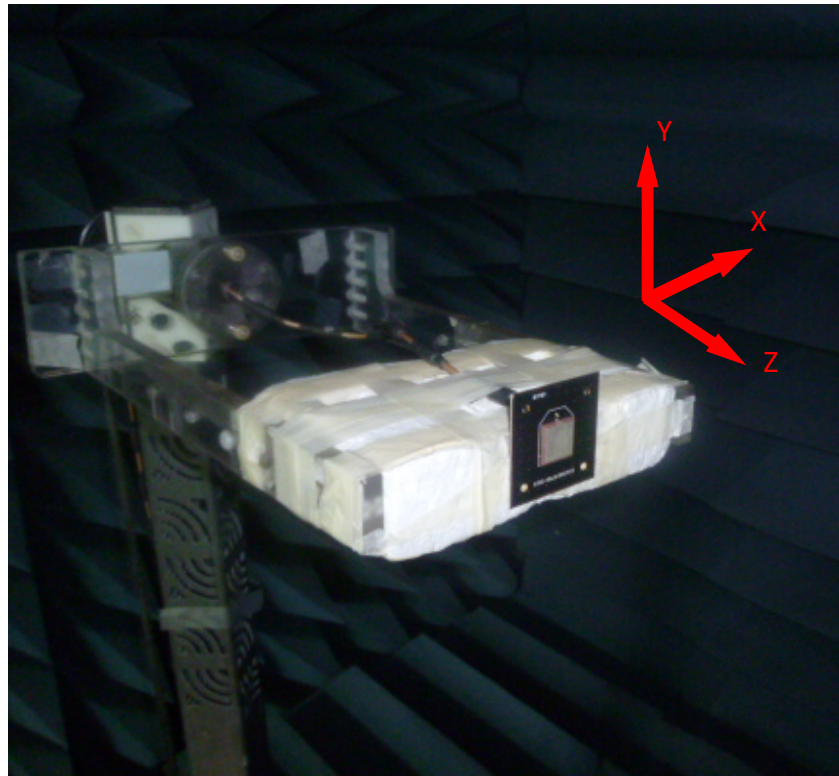

On Evaluation Board

Taoglas Part number: DSGPD.18B



4.2 1575.42MHz 3D and 2D Radiation Patterns

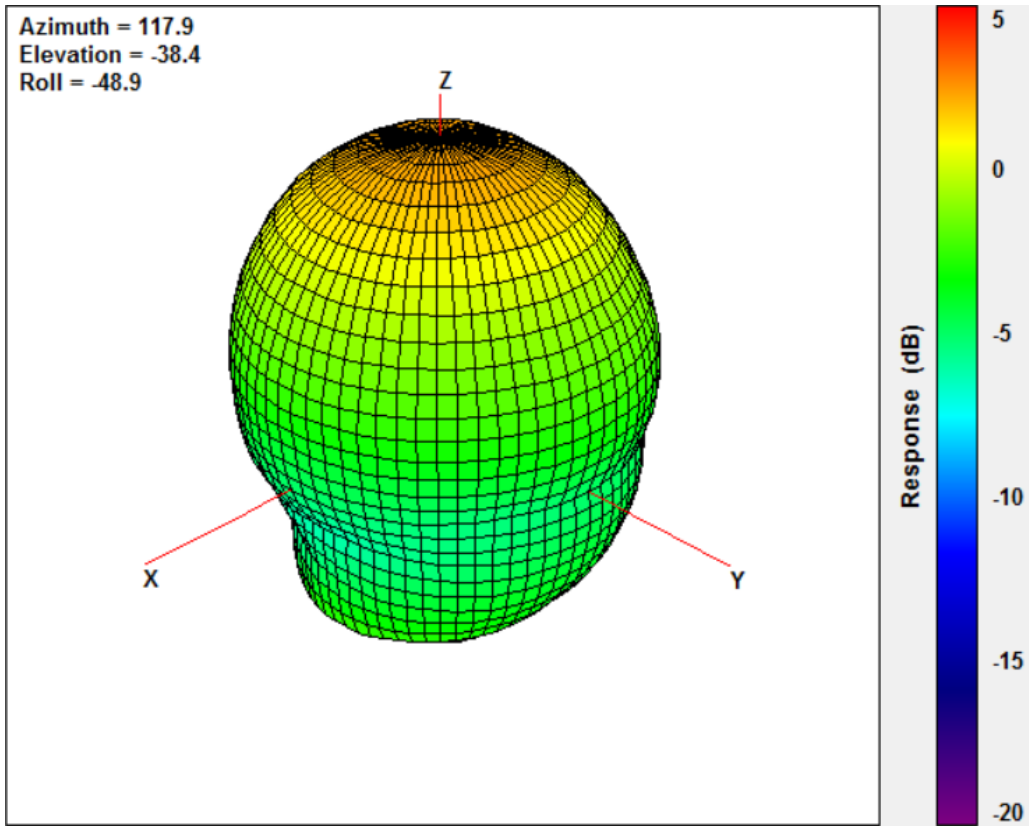

XY Plane

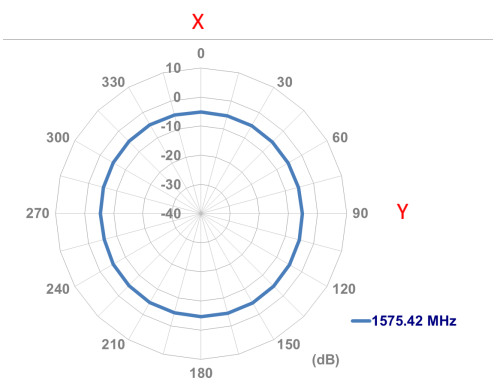

XZ Plane

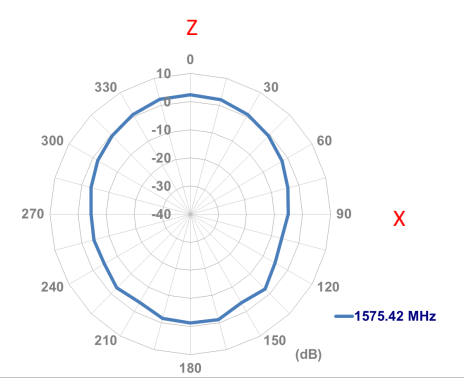

YZ Plane

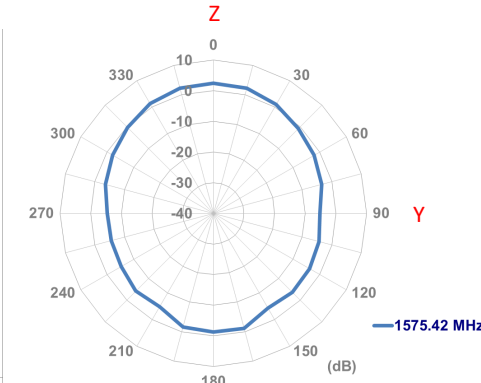



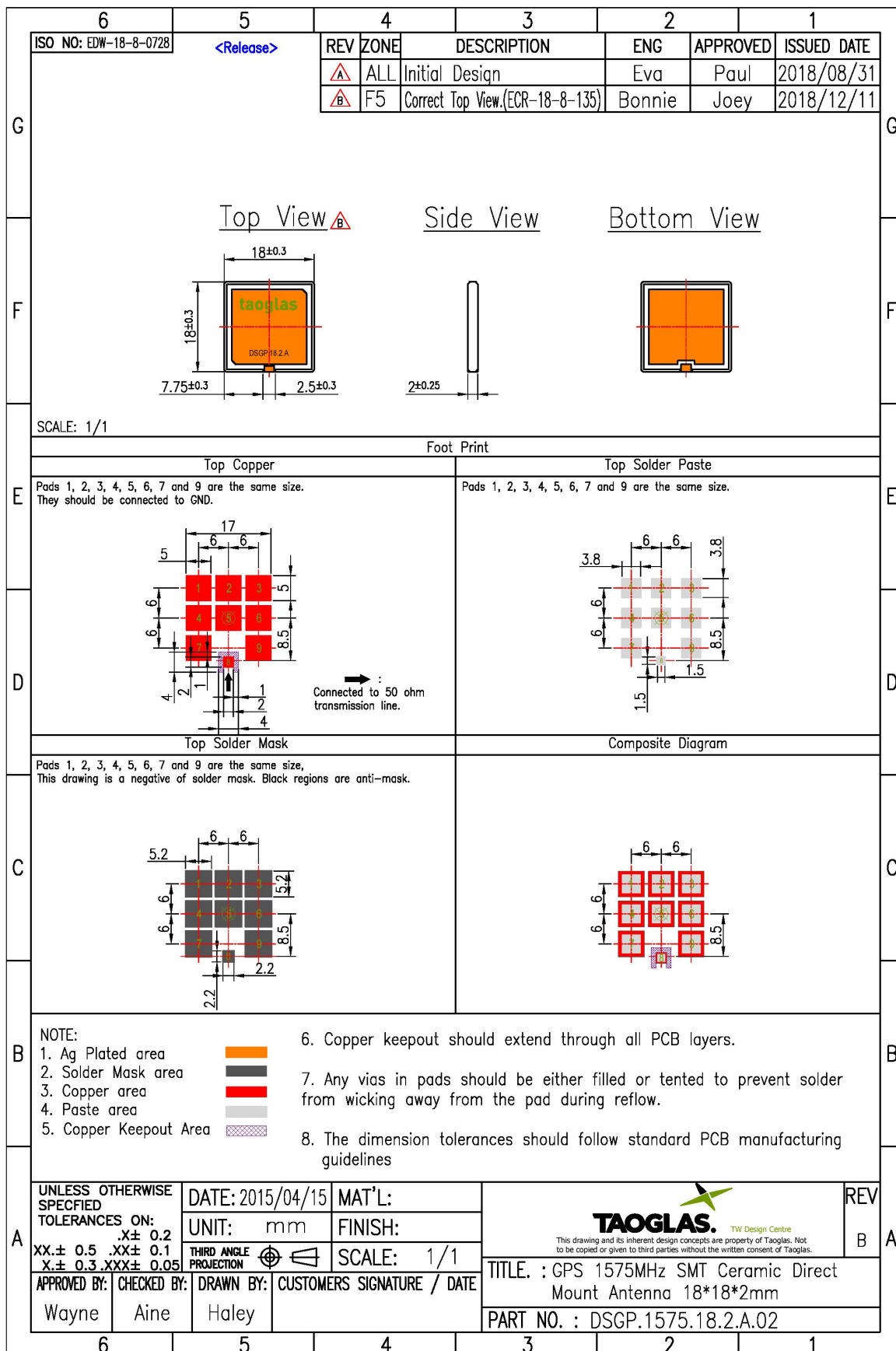

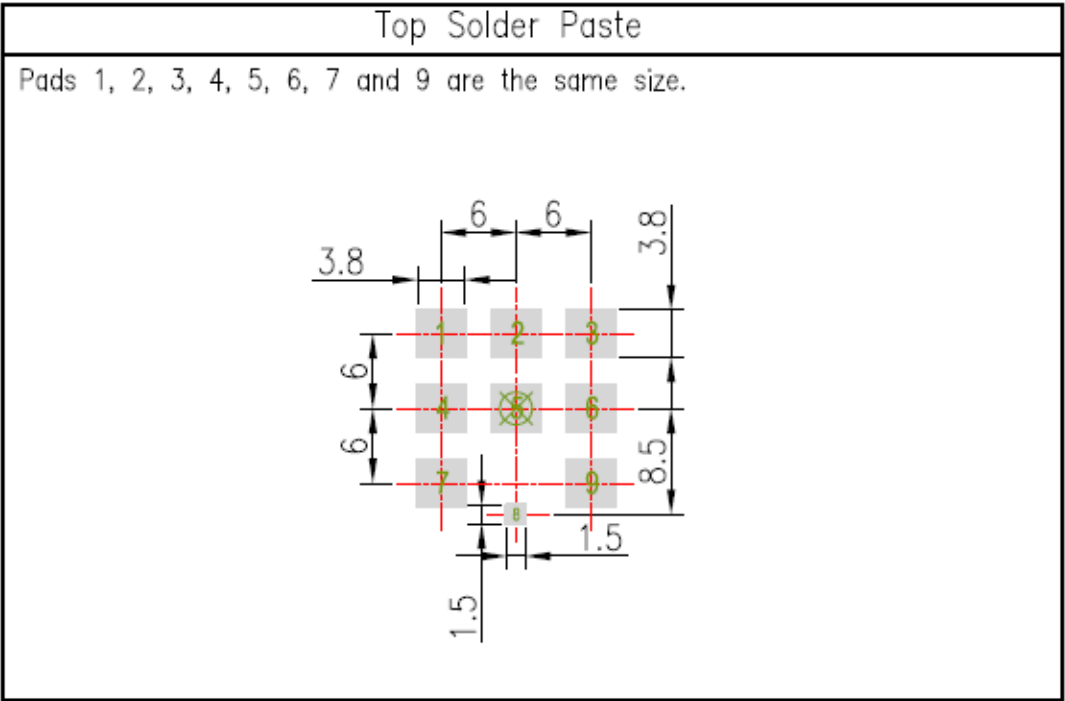
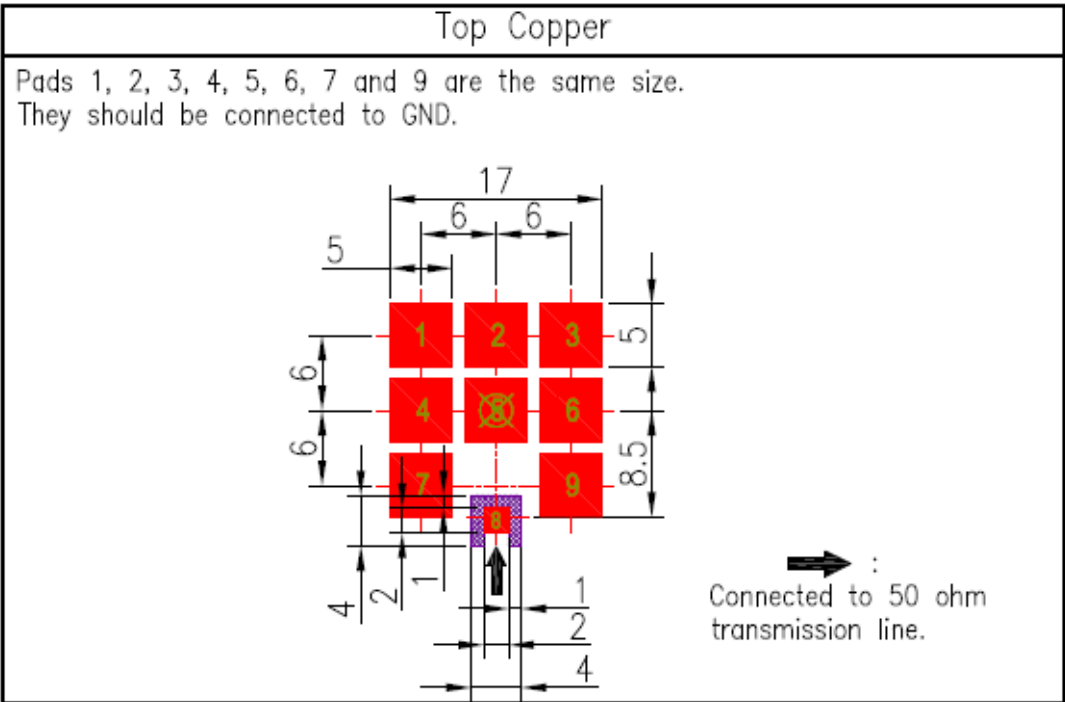

# 5. Mechanical Drawing (Units: mm)

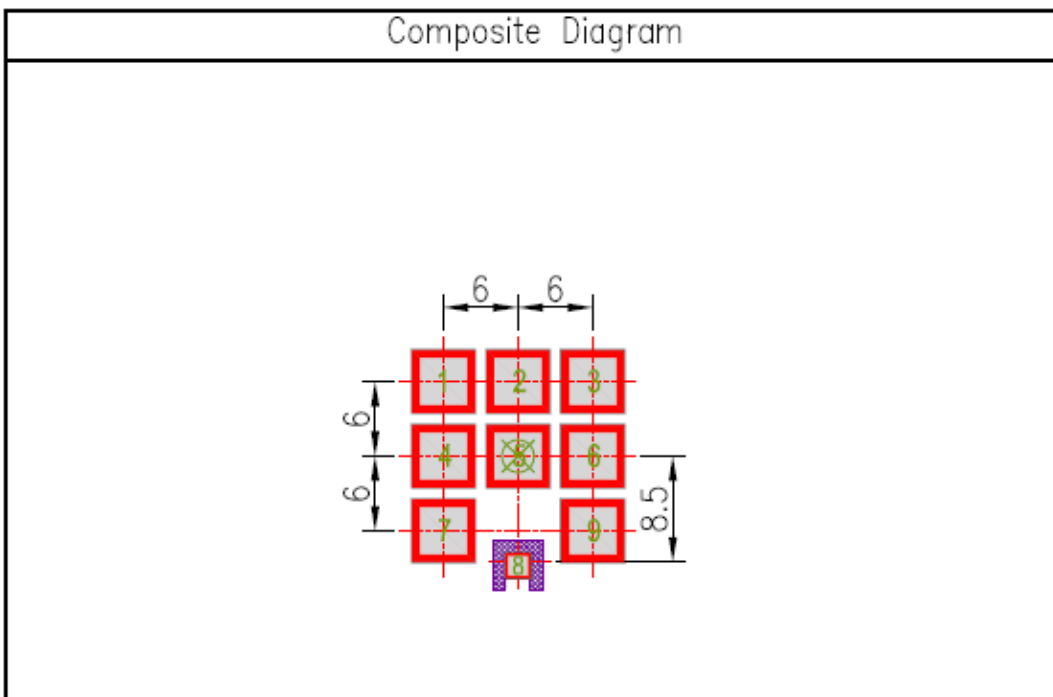
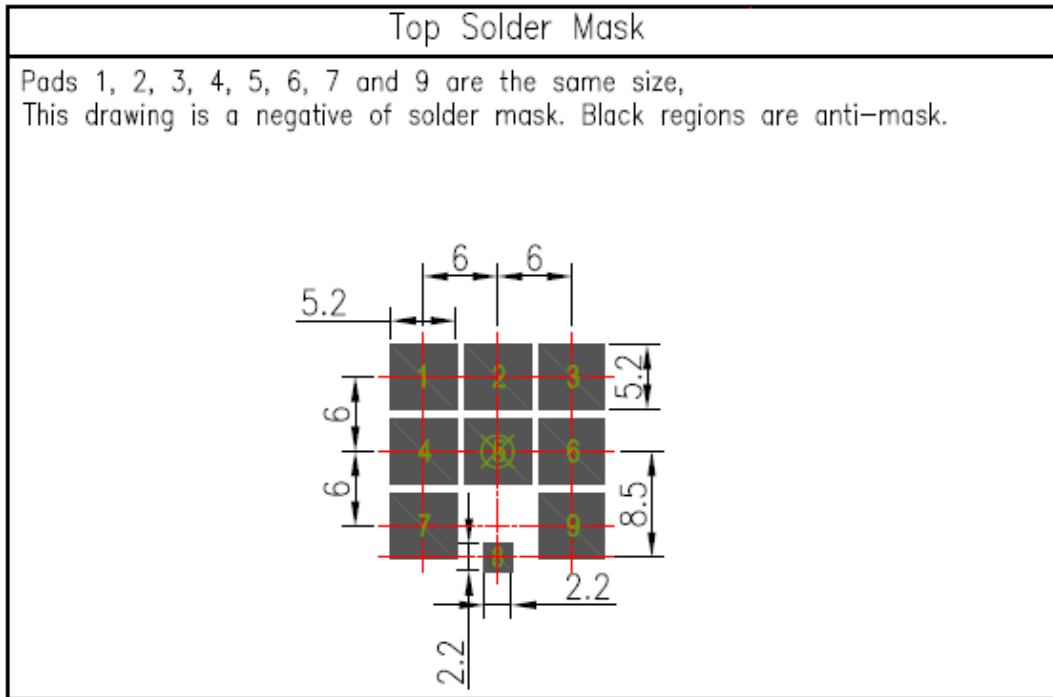

6. Footprint





- NOTE:
- |                        |   |   |
|------------------------|---|---|
| 1. Ag Plated area      |  | 6. Copper keepout should extend through all PCB layers.   |
| 2. Solder Mask area    |  | 7. Any vias in pads should be either filled or tented to prevent solder from wicking away from the pad during reflow. |
| 3. Copper area         |  |   |
| 4. Paste area          |  |   |
| 5. Copper Keepout Area |  | 8. The dimension tolerances should follow standard PCB manufacturing guidelines                                       |

## 7. Recommended Reflow Soldering Profile

DSGP.1575.18 can be assembled following Pb-free assembly. According to the Standard IPC/JEDEC J-STD-020C, the temperature profile suggested is as follows:

Phase	Profile Features	Pb-Free Assembly (SnAgCu)
PREHEAT	Temperature Min (T <sub>smin</sub> )	150°C
	Temperature Max (T <sub>smax</sub> )	200°C
	Time(t <sub>s</sub> ) from (T <sub>smin</sub> to T <sub>smax</sub> )	60-120 seconds
RAMP-UP	Avg. Ramp-up Rate (T <sub>smax</sub> to TP)	3°C/second(max)
REFLOW	Temperature (T <sub>L</sub> )	217°C
	Total Time above T <sub>L</sub> (t <sub>L</sub> )	30-100 seconds
PEAK	Temperature (T <sub>p</sub> )	260°C
	Time(t <sub>p</sub> )	2-5 seconds
RAMP-DOWN	Rate	3°C/second(max)
	Time from 25°C to Peak Temperature	8 minutes max.
	Composition of solder paste	96.5Sn/3Ag/0.5Cu
	Solder Paste Model	SHENMAO PF606-P26

The graphic shows temperature profile for component assembly process in reflow ovens

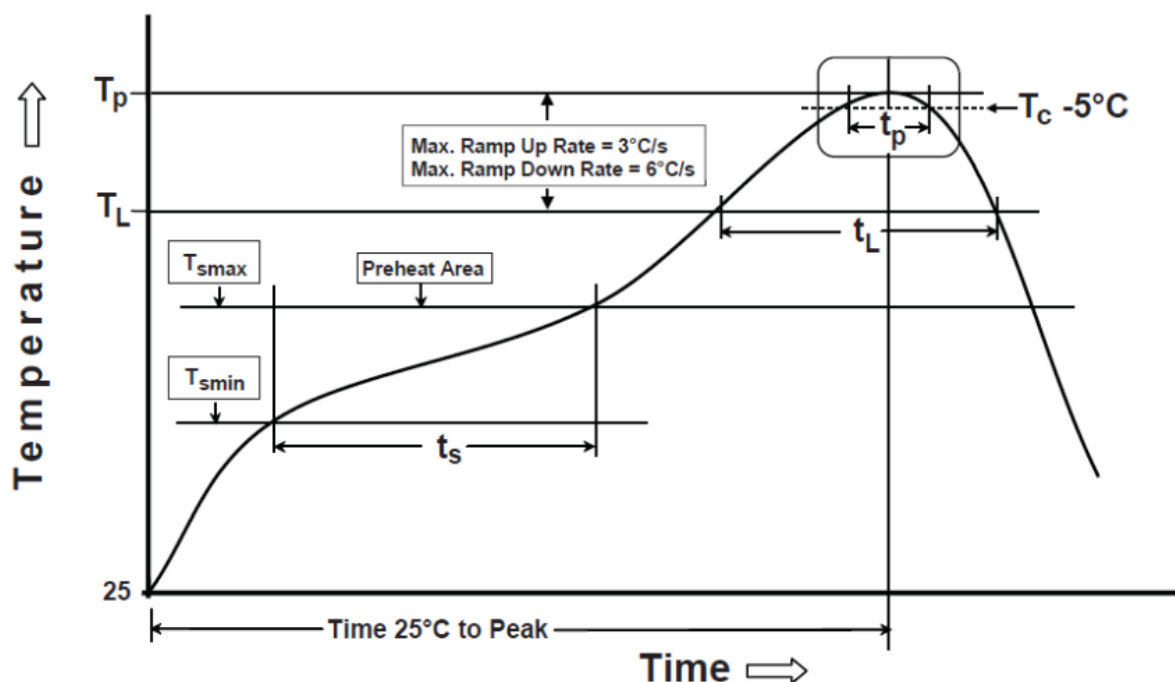

Soldering Iron condition : Soldering iron temperature 270°C±10°C.

Apply preheating at 120°C for 2-3 minutes. Finish soldering for each terminal within 3 seconds, if soldering iron temperature over 270°C±10°C or 3 seconds, it will make cause component surface peeling or damage.

## 8. Packaging

200 pc DSGP.1575.18.2.A.02 per reel  
 Dimensions -  $\varnothing 330 \times 55 \text{mm}$   
 Weight - 800g

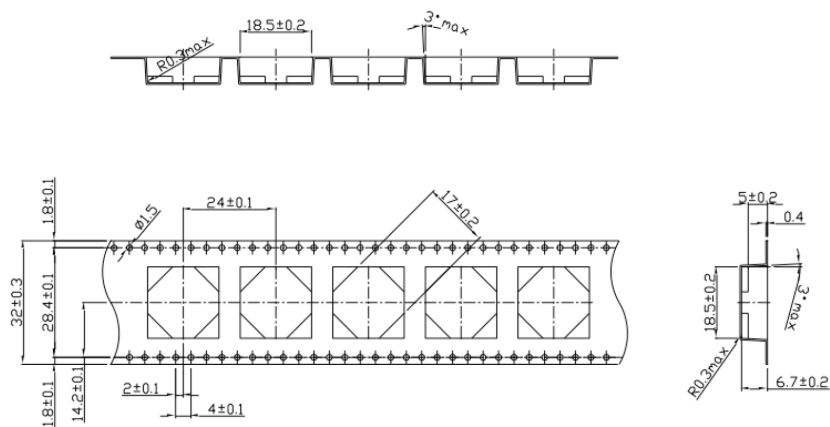
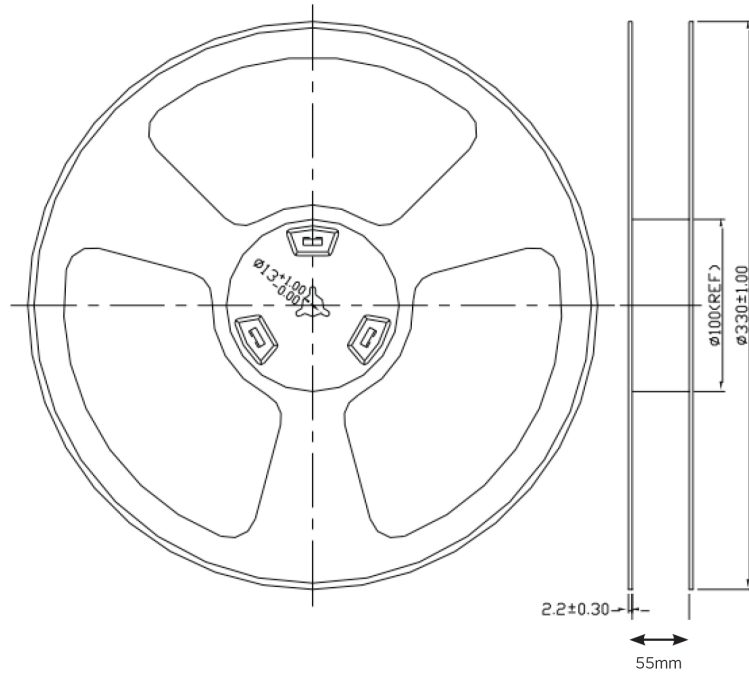

1 pc reel in small in Anti-static Bag  
 Dimensions - 340\*350\*70mm  
 Weight - 1.2Kg

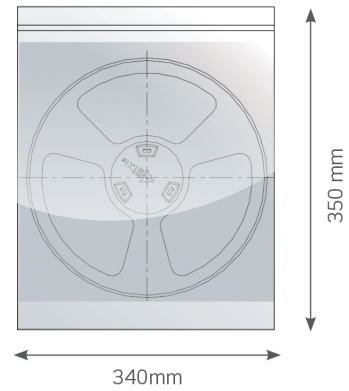

4 Reels in Anti-static Bags  
 800 pcs in one carton  
 Carton Dimensions - 370\*360\*305mm  
 Weight - 5.6Kg

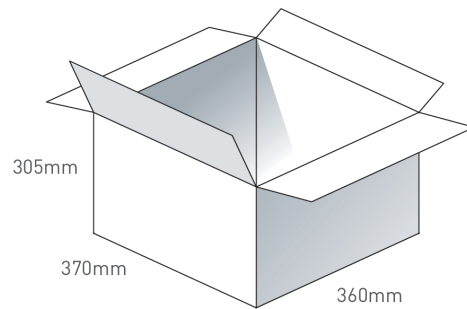

Pallet Dimensions 1200\*1000\*1420mm  
 24 Cartons per Pallet  
 6 Cartons per layer  
 4 Layers

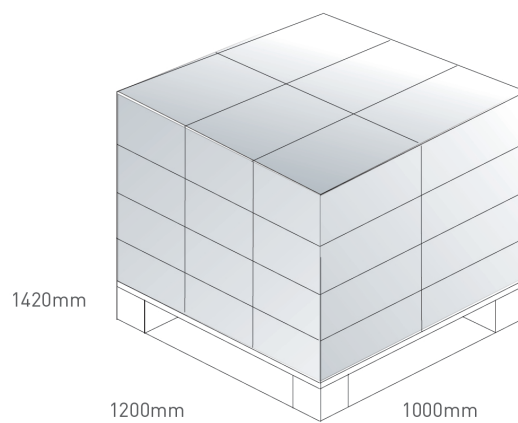

Changelog for the datasheet

**SPE-17-8-029 – DSGP.1575.18.2.A.02**

Revision: C (Current Version)	
Date:	2021-09-07
Changes:	Fixed Alignment of radiation patterns section. Added MSL rating. Fixed Font in tables.
Changes Made by:	Erik Landi

**Previous Revisions**

Revision: B	
Date:	2019-09-17
Changes:	Updated Drawing
Changes Made by:	Jack Conroy

Revision: A (Original First Release)	
Date:	2017-05-22
Notes:	
Author:	Jack Conroy





**TAOGLAS**®

[www.taoglas.com](http://www.taoglas.com)

