



Split-Core Current Transducer JC10F-XXX-V



Split-core current transducer for the electronic measurement of AC waveform currents, with galvanic isolation between the primary circuit (power) and the secondary circuit (measurement). 0-5V DC, output proportional to the RMS value of the primary current.

Applications

- HVAC & Pumps
- Refrigeration
- Small Industrial Motors
- Fans
- Lighting

Benefits

- Small-size, light-weight
- Simple Installation
- Over-Voltage protection circuit is installed.

Features

- Nylon-spring, output-terminal, secure locking hinge, one-touch structure makes easy to install to the existent equipment such as a power distribution board.
- Isolated plastic case recognized according to UL94-V0
- UL/EN 61010-1 certified

Notice

- If you impact the core contact surface, internal core material could be damaged.
- Core contact surface is waterproofed, however if it gets rusty, you could reuse after removing rusts by spraying WD-40 or CRC5-56 on the rusted side.
- Do not use any other chemicals except WD-40 or CRC5-56 on housing or any other parts.
- Please use only the original output screws.
Not recommended to replace it with anything else.

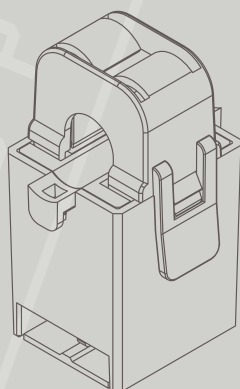
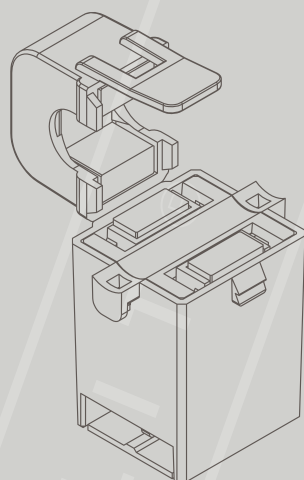

Specification

(F=50/60Hz)

Model	JC10F-XXX-V / $\phi 10$				
Current Range(Arms)	5	10	20	25	50
Max. Allowable Current	100%(Continuous), 150%(1 mim.)				
Output	0~5V DC (Average)/0- Rated Current, 7.5V DC Limiter built-in				
Accuracy / Linearity	$\pm 2\%$ FS. Dynamic Range 1:100(50/60Hz Sinewave)				
Output Impedance	7k Ω	8.5 k Ω	6.8 k Ω	6.8 k Ω	6.2 k Ω
Sensor Supply Voltage	Self-Powered				
Response Time	300ms				
Output Ripple Voltage	Within 5% of Output Voltage				
Output Terminals	2 x M3-Screw, with Terminals cover				
Insulation Category	CATIII				
Operating Condition	-20°C~+50°C, $\leq 85\%$ RH, No condensation, In-house & Any direction installable				
Storage Condition	-30°C~+90°C/ $\leq 85\%$ RH, No condensation				

How to use

Applications

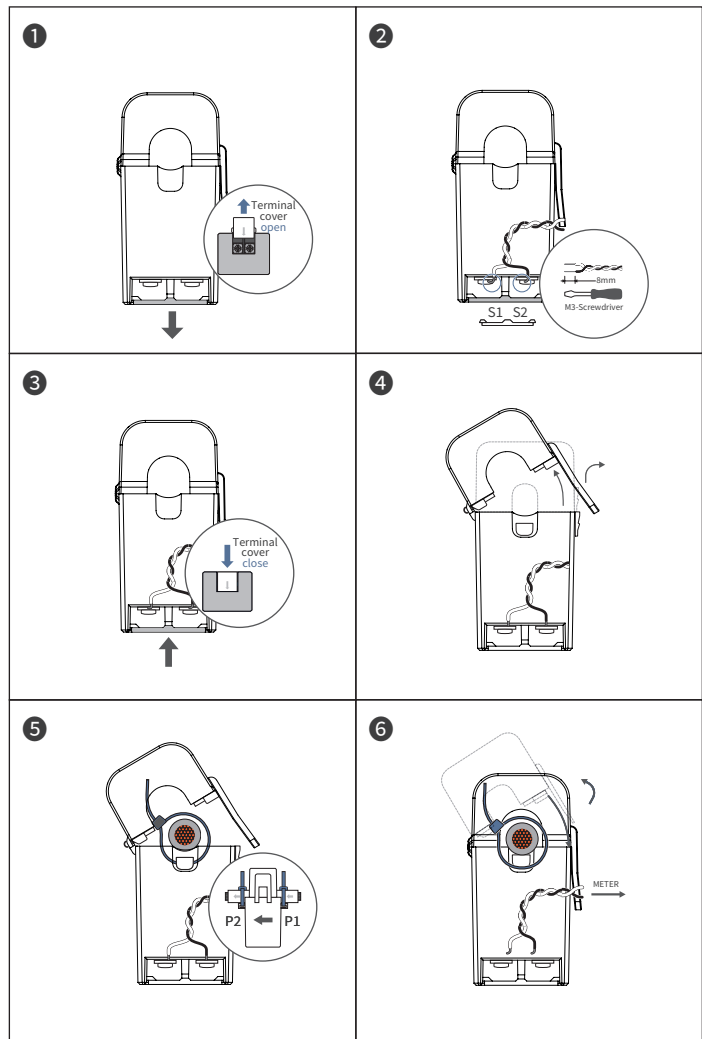
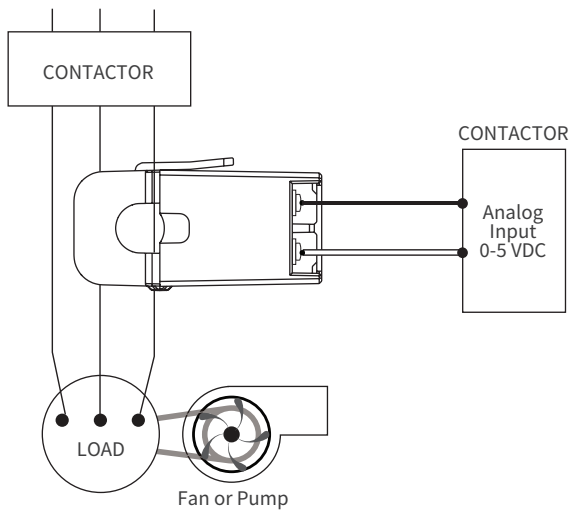

Dimensions

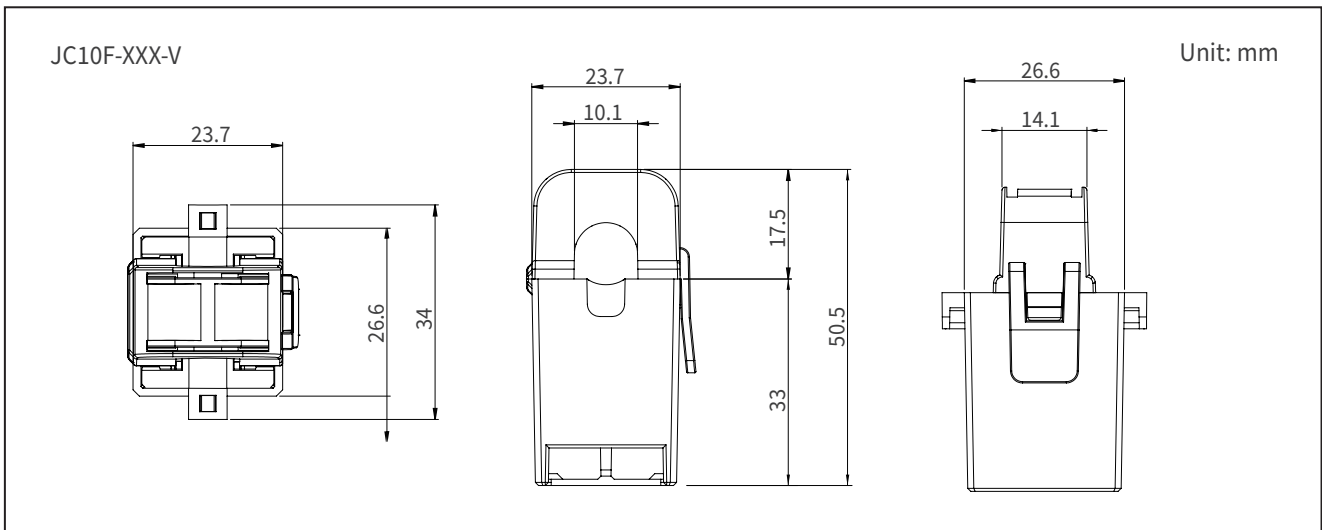

Internal Circuit Drawing

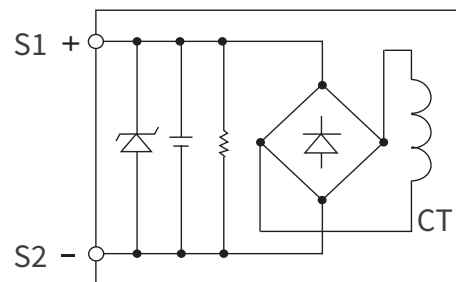

Output Voltage data

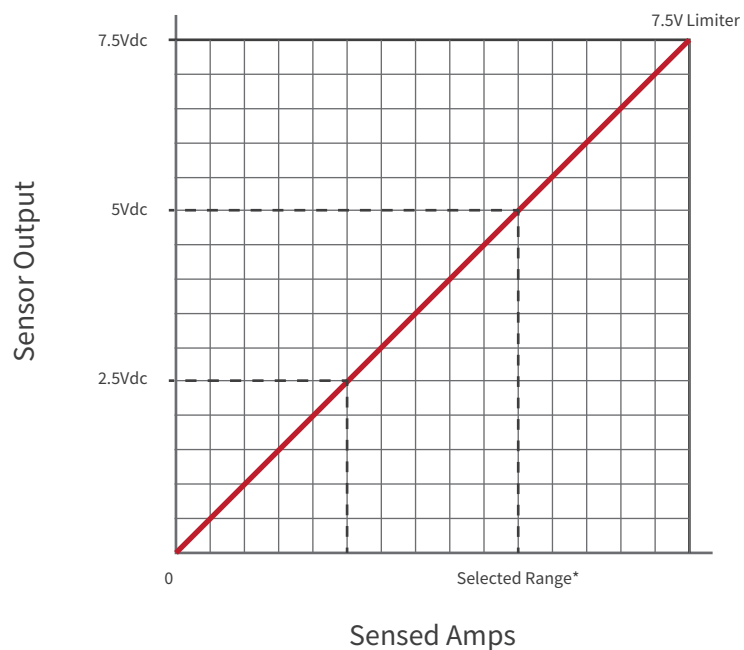

*Factory calibrated ranges selected with the amperage range switch

SAFETY

The J&D CTs are UL/EN 61010-1, CE, RoHS compliant and certified, are also conformed up to Pollution degree 2, 600Vac CAT III rated devices.

- Please be sure that Failure to follow these instructions can result in serious injury and/or cause damage. The transducer shall be used in electric/electronic equipment in accordance with the operating instructions of all related systems and component manufacturers with respect to applicable standards and safety requirements.



- Follow corresponding national regulations and safe electrical work practices. This equipment must only be installed and serviced by qualified personnel. And the qualified personnel is one who has skills and knowledge related to the construction and operation of this electrical equipment and installations, and has received safety training to recognize and avoid the hazards involved. In addition, the installation and maintenance shall be done with the main power supply disconnected except if there are no hazardous live parts in or in close proximity to the system and if the applicable national regulations are fully observed.



- When operating the transducer, there may be dangerous active voltages (e.g. primary conductor) in certain parts of the module. Users should make sure to take all necessary steps to protect against electric shock. The transducer is a built-in device containing conductive parts that are inaccessible after installation. Therefore, a protective enclosure or additional insulation barrier is necessary. Safe and trouble-free operation of this converter can only be guaranteed if transport, storage and installation are carried out correctly and operation and maintenance are carried out carefully.

REMARK

- V_o is positive when I_p flows in the direction of the arrow. (o : output, p : primary current)
- Temperature of the primary conductor should not exceed 75°C(167°F)
- Dynamic performances (di/dt and delay time) are the best with a single bar when the primary hole is completely filled.
- By hysteresis of core, offset drift occurs proportionally to the over-current higher than rating value.
- The output value fluctuates upon the various factors, so it is recommended to use the current range higher than 5% of the rated current.
- Do not use the product over the maximum current continuously.

ATTENTION

- Contact areas (air gap) must be kept clean (particle free) to ensure proper performance.